

SELECT® SL DIRECT VENT RESIDENTIAL GAS WATER HEATERS



Side-Mounted Taps Designed for Recirculating Systems

- Suitable for water heating and space heating

Direct Vent Design

- One-pipe, dual channel closed-combustion system draws all make-up air from outside the home, eliminating issues caused by insufficient indoor ventilation. Horizontal air intake and venting on all models up to 80 inches from outside wall, with no electrical power needed

FVIR Compliant Design

Diffuser Dip Tube

- Reduces lime and sediment buildup, maximizes hot water output
- Made of PEXAN™, a cross-linked PEX polymer that can withstand long-term exposure to water temperatures up to 400°F

Green Choice® "Eco-Friendly" Gas Burner

- Patented design reduces NOx emissions by up to 33% compared to standard burners

Durable Brass Tamper-Resistant Drain Valve

Glasslined Tank

- For long-lasting protection against corrosion

Push Button Piezo Ignitor

- Simplifies lighting pilots with one-hand spark ignition

Anode Rods

- For added protection against corrosion

Factory-Installed CSA Certified and ASME Rated T&P Relief Valve

Thick, "Environmentally-Friendly" Non-CFC Foam Insulation

- Reduces standby heat loss and improves efficiency

6-Year Limited Tank and Parts Warranty



Code Compliance - All models meet the Federal Energy Efficiency Standards effective January 20, 2004, according to the National Appliance Energy Conservation Act (NAECA) of 1992 and the thermal efficiency and standby loss requirements of the U.S. Department of Energy and current edition of ASHRAE/IESNA 90.1. Also complies with the current editions of the B.O.C.A. National Codes, C.E.C., U.B.C., S.B.C.C., C.A.B.O. and the H.U.D. standards.



For more information on Select® SL contact:

State Water Heaters
500 Tennessee Waltz Parkway
Ashland City, TN 37015
1-800-365-0024 Toll-free USA
www.statewaterheaters.com

SOLID.STATE.



SELECT® SL - DIRECT VENT RESIDENTIAL GAS WATER HEATERS

MODEL NUMBER	GALLON CAPACITY	ENERGY FACTOR (EF)	BTU INPUT PER HOUR NATURAL	RECOVERY 90°F RISE	BTU OUTPUT PER HOUR NATURAL	FIRST HOUR RATING	DIMENSIONS IN INCHES								APPROX. SHIPPING WEIGHT (LBS)
							*A	B	C	D	E	F	G	H	
GS6 40 YBDS L	40	0.62	38,000	41	30,780	73	68	54-3/4	22-1/4	16	12-1/4	45-1/4	16-1/2	41-3/4	167
GS6 50 YRDS L	50	0.59	50,000	55	40,500	88	76	64-3/4	22-1/4	16-1/4	12-1/2	55-1/2	16-1/2	53-3/4	187
GS6 75 YRDS L	75	0.59	55,000	60	44,550	131	76	65-3/4	26-1/4	16-1/4	12-1/2	55-1/2	17-1/4	54	310

Recoveries are rounded to nearest gallon

Water Connections - 3/4" on all models

Dual-channel system has 3" vent pipe inside 6" air intake pipe for the 40 & 50-gallon models. The 75-gallon model uses a 4"x7" Co-Axial Pipe.

*A Dimension is to center line of flue (recommended vent height)

When ordering propane, change "Y" to "H" in the model number (Example: GS6 40 HBDS L)

All models have 2" foam cavity

All 75-gallon water connections are 12" on center

Optional Circulating Loop Fittings Package, Part No. 9002604005

Circulating Loop Fittings Package includes assembled di-electric unions and full port shut-off valves. A standard hose-connect drain valve is included for field installation. Specially designed for use on side tap recirculating water heaters. Kit must be ordered through Service Parts Department by calling 1-800-821-2017.

Important! Vent Installation and Termination Requirements

- Maximum horizontal vent distance is 80" to outside of exterior wall
- Minimum horizontal vent distance is 17" to outside of exterior wall
- Vent pipes may be trimmed (cut) for short vent installations
- For vent installation less than 30" the vent restrictor is required. Place restrictor over the flue outlet on heater before installing the outlet vent pipe to the heater
- Recommended installation height for the heater and vent pipe should be 68" for 40-gallon models and 76" for the 50 and 75-gallon models (vent height)
- Offset Vent Arrangement
 1. When replacing an existing direct vent model, the new vent pipe may drop from the minimum vent height as much as 7-1/4" to exit through the existing vent opening in the exterior wall
 2. Vent may have one horizontal 90° degree turn before exiting through exterior wall (Do not combine both offset vent arrangements in one installation) (See examples in the installation manual)
- High Rise Vent Arrangement
 3. When vent termination is more than 80" above the base of the heater. The horizontal vent runs must be a minimum of 22" from the center of the heater to the outside exterior wall surface. (See example in the installation manual)
- Vent termination clearance hole through the exterior wall should be approximately 7" diameter
- Snow acculation and drifting should be considered when locating the termination
- An optional wire grill vent cap protector is available through the parts department. Request part number 9006627005.
- See the installation manual for complete installation and venting requirements.

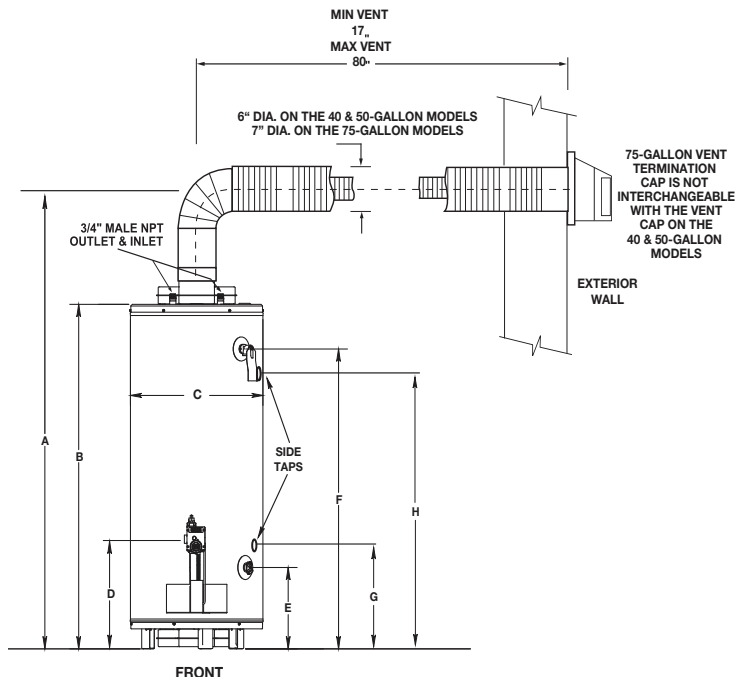
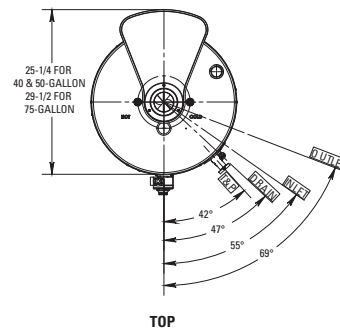

For complete information on limited warranties, consult written warranty or contact technical support at 1-800-365-0024.

State Industries, Inc., reserves the right to make product changes or improvements without prior notice.

For more information on Select® SL contact:

State Water Heaters
 500 Tennessee Waltz Parkway
 Ashland City, TN 37015
 1-800-365-0024 Toll-free USA
 www.statewaterheaters.com

SOLID.STATE.

