

PUMP TANKS

PUMP MATE™ PRE-PRESSURIZED

- Drawn steel construction
- Diaphragm operation
- SPMD corrosion resistant plastic base
- SSB metal base
- Lightweight
- Maximum working pressure 100 PSI
- 5-year limited warranty

HEAVY DUTY STATE SELECT® GLASSLINED

- Rolled steel construction
- Fused glasslining
- Anodic protection
- Maximum working pressure 125 PSIG
- 5-year limited warranty

GALVANIZED TANKS

- 100% galvanized
- 1-year limited warranty



Heavy Duty State Select® Glasslined



Pump Mate™ Pre- Pressurized Tanks
Plastic Base



Pump Mate™ Pre- Pressurized Tanks
Metal Base



Pump Mate™ Pre- Pressurized Tanks
Horizontal

PUMP MATE™ PRE-PRESSURIZED DIAPHRAGM OPERATION 5-YEAR LIMITED WARRANTY

State Industries Pump Mate™ tanks are designed for installation flexibility and years of trouble-free service. Smooth, dependable diaphragm design and operation provides precise control of system operation cycles. Free-standing and in-line vertical tanks are available, as well as horizontal tanks with universal pump mounting bracket.

HIGHER DRAWDOWN THAN COMPETITION!

The industry's most popular "standard" tank sizes are 32-gallon and 44-gallon. Pump Mate™ offers 36 gallon and 52-gallon tanks in the same price range. So, a 36-gallon Pump Mate™ delivers 12% higher drawdown than the industry standard. A 52-gallon Pump Mate™ delivers 18 % higher drawdown than standard.



IN-LINE TANKS

SPMDI Series tanks, available 2, 4.6, 7.3 and 14-gallon sizes are designed to be supported by system piping (see typical installations, page 4).



Projection welded air valve.

Butyl rubber parabolic diaphragm ensures separation of air and water. Steel retaining ring "seals" diaphragm directly to tank.

Powder coated water chamber, bonded to shell, proven protection against rust.

Rotating corrosion resistant base assures stability. Rotates for easy alignment to connection. Slotted and notched for proper airflow, reduced condensation.

PRE-PRESSURIZED PUMP TANK OPERATION CYCLES



START-UP CYCLE*

Diaphragm is pressed against the bottom of the chamber.



FILL CYCLE*

Water is pumped into the reservoir, which forces the diaphragm upward into the air chamber



HOLD CYCLE*

Pump-cutoff pressure is attained. Diaphragm reaches its uppermost position. Reservoir is now filled to its rated capacity.

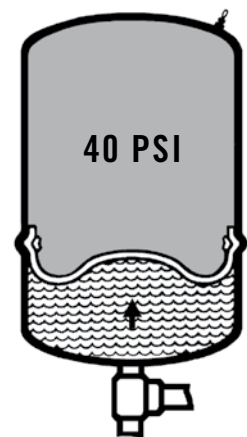

DELIVERY CYCLE*

Pump remains shut off while air pressure in top chamber forces diaphragm downward, delivering water to system.

*Based on 30-50 operating system.

PUMP MATE™ PRE-PRESSURIZED DIMENSIONS AND WEIGHTS

	Model Number	Volume (Gallons)	Dimensions in Inches			Weight (lbs)
			"A" Overall Height	"B" To Center of Water Inlet	"C" Diameter	
SPMD Series Free Standing Plastic Base	SPMD-14	14	24-3/4	2-1/4	15-3/8	25.5
	SPMD-20	20	32-3/4	2-1/4	15-3/8	30
	SPMD-31	31	45-1/2	2-1/4	15-3/8	40
	SPMD-36S	36	32-3/8	2-1/4	20	45
	SPMD-52	52	38-5/8	2-1/4	23-3/8	77
	SPMD-86	86	59	2-1/4	23-3/8	105
	SPMD-96	96	63-3/8	2-1/4	23-3/8	111
	SPMD-119	119.5	61-1/4	2-1/2	26	165
SSB Series Free Standing Metal Base	SSB20	20	32-3/4	2-1/4	15-3/8	30
	SSB32	32	45-1/2	2-1/4	15-3/8	40
	SSB36	36	32-3/8	2-1/4	20	45
	SSB52	52	38-5/8	2-1/4	23-3/8	77
	SSB65	65	46-5/8	2-1/4	23-3/8	87
	SSB86	86	59	2-1/4	23-3/8	105
	SSB119	119.5	61-1/4	2-1/2	26	165
SPMDI Series In-Line	SPMDI-2	2	10-3/16	–	8-1/4	5
	SPMDI-5	4.6	14-3/4	–	11	9
	SPMDI-7	7.3	21-1/8	–	11	14
	SPMDI-14	14	21-3/4	–	15-3/8	24
SPMDH Series Horizontal				"B" Overall Length		
	SPMDH-7	7.3	12-7/8	21-1/8	11	16
	SPMDH-14	14	17-3/8	21-3/4	15-3/8	25.5
	SPMDH-20	20	17-3/8	27-1/8	15-3/8	30

SPMD-14, SPMD-20, SPMD-36S connection 1" female.
 SPMD-52, SPMD-86, SPMD-96, SPMD-119 connection 1-1/4" female.
 SPMDI connection 3/4" male. SPMDI-14 1" male.
 SPMDH-7 connection 3/4" male. *SPMDH-14, SPMDH-20 connection 1" male.

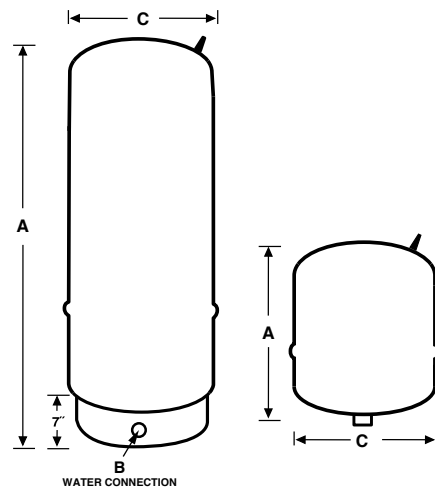
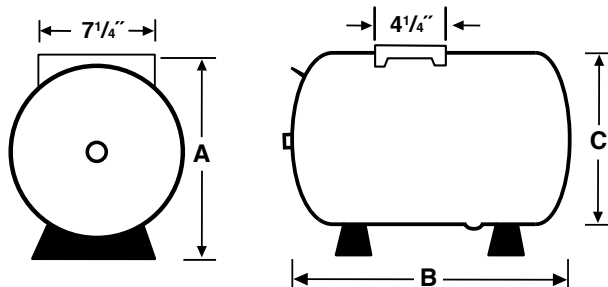

Certified to NSF/ANSI
61-G and 372



Residential Pump Tanks

PUMP TANK SIZING

FREE-STANDING SELECTION CHART

The charts below allow you to easily select the right free-standing tank for standard size pumps between 2-1/2 and 30 gallons in capacity and for 20-40 PSI, 30-50 PSI and 40-60 PSI pressure ranges. Minimum run times shown (from start-up) are 1 minute, 1- 1/2 minutes and 2 minutes. For example, for a system that delivers 10 gpm at 30-50 PSI, with a minimum run time of 1 minute, Chart 1 indicates that the proper tank is the SPMD-36S.

Pump GPM	System Pressure Ranges PSI								
	20-40			30-50			40-60		
	Minimum Run Times (Minutes)								
	1	1-1/2	2	1	1-1/2	2	1	1-1/2	2
2.5	SPMD-14	SPMD-14	SPMD-14	SPMD-14	SPMD-14	SPMD-20	SPMD-14	SPMD-20	SPMD-20
5	SPMD-14	SPMD-20	SPMD-36S	SPMD-20	SPMD-36S	SPMD-36S	SPMD-20	SPMD-36S	SPMD-52
7	SPMD-20	SPMD-36S	SPMD-52	SPMD-36S	SPMD-36S	SPMD-52	SPMD-36S	SPMD-52	SPMD-86
10	SPMD-36S	SPMD-52	SPMD-86	SPMD-36S	SPMD-52	SPMD-86	SPMD-52	SPMD-86	SPMD-86
12	SPMD-36S	SPMD-52	SPMD-86	SPMD-52	SPMD-86	SPMD-86	SPMD-52	SPMD-86	SPMD-96
15	SPMD-52	SPMD-86	SPMD-86	SPMD-52	SPMD-86	SPMD-119	SPMD-86	SPMD-96	SPMD-119
20	SPMD-86	SPMD-86	SPMD-119	SPMD-86	SPMD-119	(2) SPMD-86	SPMD-86	SPMD-119	(2) SPMD-86
25	SPMD-86	SPMD-119	(2) SPMD-86	SPMD-86	(2) SPMD-86	(2) SPMD-86	SPMD-96	(2) SPMD-86	(2) SPMD-96
30	SPMD-86	(2) SPMD-86	(2) SPMD-86	SPMD-119	(2) SPMD-86	(2) SPMD-119	SPMD-119	(2) SPMD-96	(2) SPMD-119

IF PROPER TANK SELECTION CANNOT BE MADE USING CHART 1, FOLLOW THIS PROCEDURE:

First find the "drawdown multiplier" by matching the pump start-up and shut-off pressures on Chart 2. For example, the multiplier for a 30-50 PSI pressure range is .31. Next, insert the pump GPM capacity and desired minimum run time into this formula:

$$\frac{\text{PUMP GPM} \times \text{Min. Run Time}}{\text{Multiplier}} = \text{Minimum Tank Volume Required}$$

To assume dependable Drawdown Volumes, and in keeping with present industry practice, Drawdowns are based on Boyles Law.

For example, using a 10 GPM pump, a one-minute minimum run time, and a 30-50 PSI pressure range, the formula is as follows:

$$\frac{10 \times 1}{.31} = 32.25 \text{ Minimum Tank Volume}$$

Then, using Chart 3, select the tank that has a minimum volume that meets or exceeds your minimum volume requirement, and supplies adequate drawdown at the required pressure range. Minimum drawdown equals Pump GPM x Minimum Run Time. Therefore, in the above example, select the SPMD- 36S 36-gallon tank. It provides adequate drawdown at 30-50 PSI.

Pump Shut-Off Pressure	Pump Start-Up Pressure-PSI							
	10	20	30	40	50	60	70	80
20	0.26							
30	0.41							
40		0.22						
50		0.37	0.18	0.15				
60		0.46	0.31	0.27	0.13			
70			0.40	0.35	0.24	0.12		
80			0.47	0.42	0.32	0.21	0.11	
90				0.48	0.38	0.29	0.19	0.1
100					0.44	0.35	0.26	0.17

Model Number	Vol. in Gallons	20-40	30-50	40-60
SPMDI-2	2.0	0.7	0.6	0.5
SPMDI-5	4.6	1.7	1.4	1.2
SPMDI-7	7.3	2.7	2.3	2.0
SPMD-14	14.0	5.2	4.3	3.8
SPMD-20	20.0	7.4	6.2	5.4
SPMD-31	31.0	11.4	9.6	8.4
SPMD-36S	36.0	13.3	11.2	9.7
SPMD-52	52.0	19.2	16.1	14.0
SPMD-86	86.0	31.8	26.7	23.2
SPMD-96	96.0	35.5	29.8	25.9
SPMD-119	119.5	44.2	37.0	32.3

RULE OF THUMB SYSTEM SIZING

The following water requirements figures are based on averages accepted by the industry. They represent typical household and farm animal water use requirements. Generally speaking, a reliable daily average water requirement is 100 gallons per day per person.

AVERAGE DAILY FARM ANIMAL REQUIREMENTS

	Gallons/Day
Horse, Mule, Steer	12
Cow-Dry	15
Cow-Milking	35
Hog	4
Sheep	2
Chicken/100	6
Turkey/100	20

AVERAGE HOME WATER REQUIREMENTS BASED ON INDUSTRY-ACCEPTED 7-MINUTE PEAK DEMAND CYCLE

Unit	Flow Rate GPM	Requirement Gallons
Kitchen Sink	5	3
Toilet	4	5
Lavatory	4	2
Tub or Shower	5	35
Auto Wash Machine	5	35
Dishwasher	2	14
Garden Hose (1/2")	3	Depends upon cycle time
Lawn Sprinkler	3-7	
Water Softner	7	

AVERAGE HOUSEHOLD WATER REQUIREMENTS (GPM) USING INDUSTRY-ACCEPTED 7-MINUTE PEAK DEMAND CYCLE

No. of Bathrooms	Type of Water Using Fixtures Installed	GPM Required
1	Sink, Toilet, Lavatory Tub/Shower	7
1-1/2	Same as Above with Automatic Washer	10
2- 2-1/2	Same as Above with Automatic Dishwasher	14
3-4	Same as Above	17

TYPICAL INSTALLATIONS

FOR MULTIPLE INSTALLATIONS, MANIFOLD SIZE IS CRITICAL. IF YOU HAVE QUESTIONS ABOUT SIZES CALL OUR TECHNICAL ENGINEERING SERVICES DEPARTMENT AT 1-800-365-0024.

FREE-STANDING SERIES*

The standard installation, utilizing front entry, with gauge, reliefvalve and pressure switch installed in front of tank.

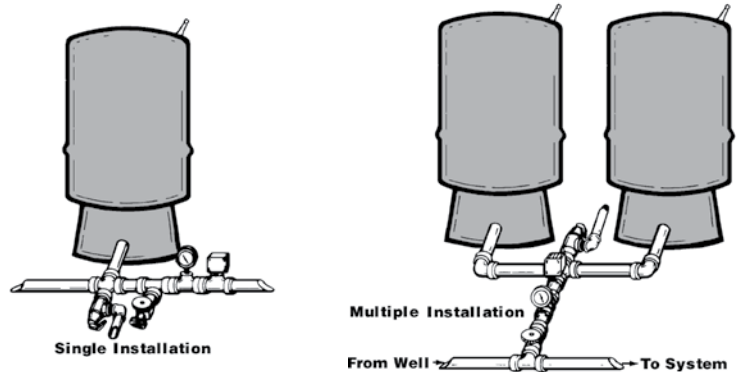

FREE-STANDING SERIES WITH PUMP MOUNTED ON TANK*

The pump can be mounted on tank using a universal mounting base. The pump and base can be strapped to the tank in the horizontal position, or mounted to the tank in a vertical position.

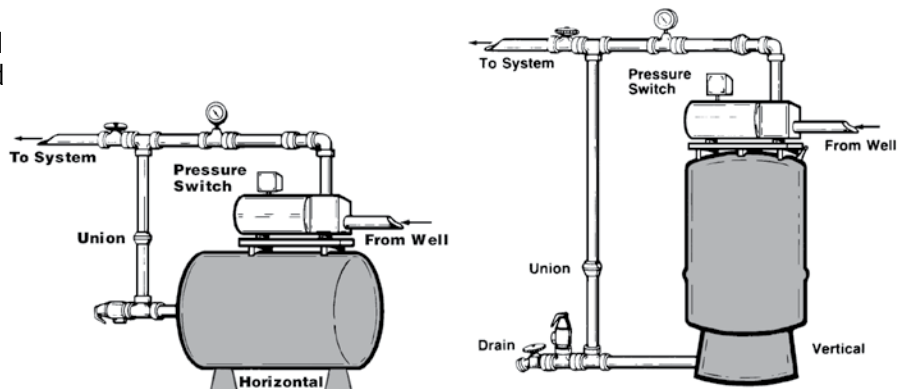

IN-LINE SERIES*

The In-Line Series is designed to be supported by system piping, either directly above the pump, or in a convenient place in the piping system as close to the pump as possible.

* When pump and tank are in different locations, the pressure switch should be at the tank location. Or compensating adjustment must be made for pressure loss due to head of water, i.e., one PSI for every two feet of elevation.

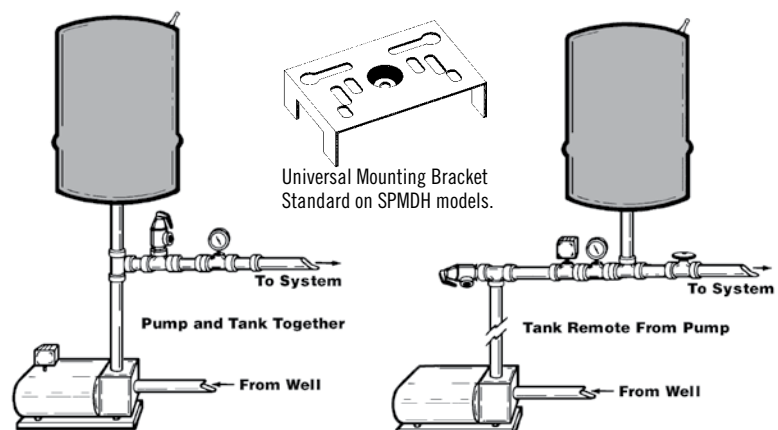

STATE SELECT® HEAVY DUTY GLASSLINED

“Glasslining,” a porcelain protective coating to a steel tank interior, is the plumbing industry’s most time-tested system for protection against tanks. State Select® Glasslined Pump Tanks feature rolled-steel construction. State Water Heaters is one of the world’s largest producers of glasslined tanks, and every tank is made in the U.S.A. Other features include a 1-1/4” NPT spud on top for motor mount or retention tank connections, a 1/4” switch or gauge tapping on the air side of the tank, and full-size 1-1/4” connections at all needed locations.

- Rolled Steel Construction
- Fused Glasslining
- Maximum working pressure 125 PSIG
- Anodic Protection
- 5-Year limited warranty



G SERIES GLASSLINED PUMP TANKS

Model Number	Volume (Gallons)	Dimensions in Inches						Weight (lbs)
		A	B	C	D	E	F	
G-42-T	42	49	26	16-1/2	12	3	6	69
G-42-S	42	35-7/8	17	20	8	3	6	79
G-82	82	62-1/4	33	20	12	3	6	154
G-120	120	63	33	24	12	3	6	206

A STANDARD RETENTION SYSTEM

TYPICAL INSTALLATION OF RETENTION TANK WITH CHEMICAL FEED PUMP

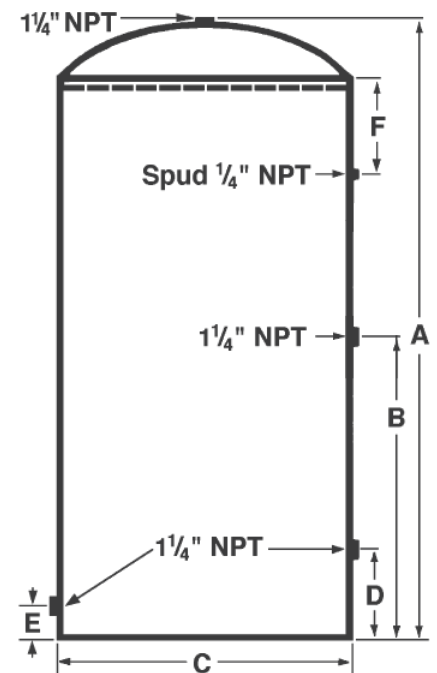
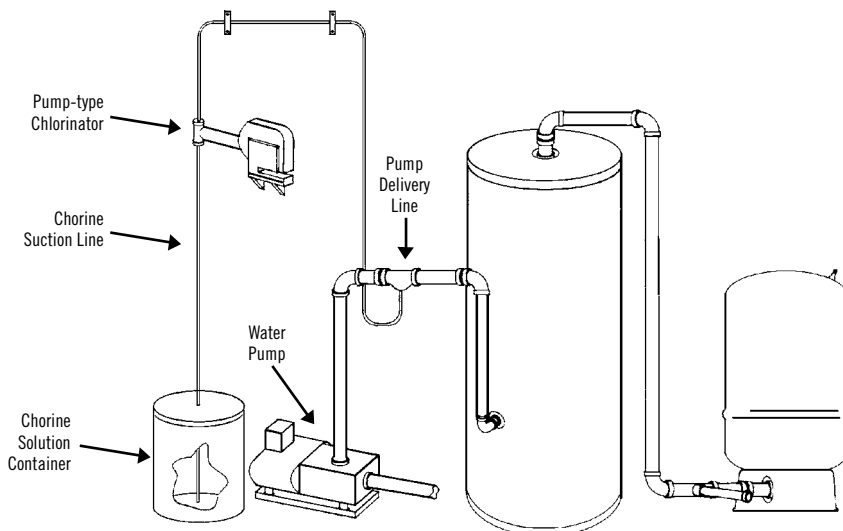

GALVANIZED TANKS

- Vertical Tanks
- Maximim working pressure 75 PSIG
- NSF Certified 61G & 372
- 1-Year limited warranty

Model Number	Volume (Gallons)	Dimensions in Inche									Weight (lbs)
		A	B	C	D	E	G	J	K	L	
Z-220	220	78	66	30	6	32	6	2-1/2	2	2	303
Z-315	315	79-1/2	66	36	6	32	7	2-1/2	2	2	416
Z-480	480	87	72	42	6	32	7-1/2	2-1/2	2	3	640

Model Number	Volume (Gallons)	Dimensions in Inche					Weight (lbs)
		A	B	C	D	E	
Z-12	12	26-1/2	24	12	5	13	27
Z-21	21	26-7/8	24	16	5	13	45
Z-32	32	38-3/4	36	16	8	17	52
ZT-42	42	51	48	16	12	26	71
ZS-42	42	33-5/8	30	20	8	17	71
Z-82	82	63	60	20	12	33	114
Z-120	120	64-1/2	60	24	12	33	154

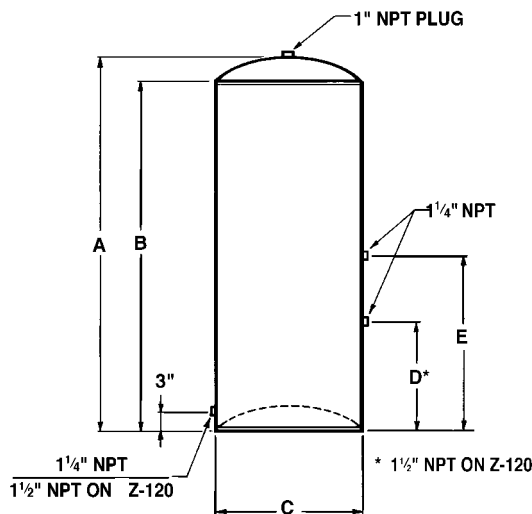
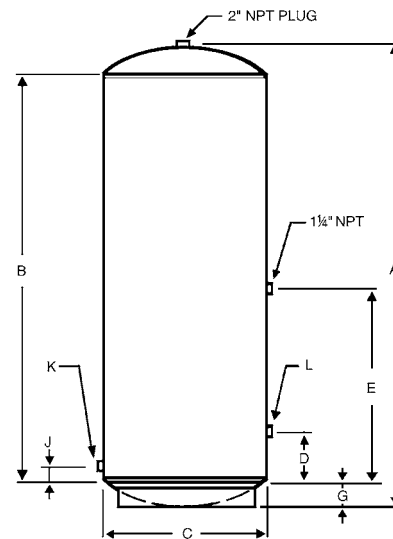

Models: ZU-525 & ZU-900										
Model Number	Volume (Gallons)	Dimensions in Inches							Weight (lbs)	
		A	B	C	D	E	F	G		J
ZU-525	525	131	114	36	6	56	2-1/2	2-1/2	2" NPT	685
ZU-900	900	161	144	42	14	69	4	4	3" NPT	1040

1" NPT Spud in head for alternate motor mount or retention tank connection.
 All tapping 1-1/4" Water Connections.
 1/4" pressure switch tapping on all models.

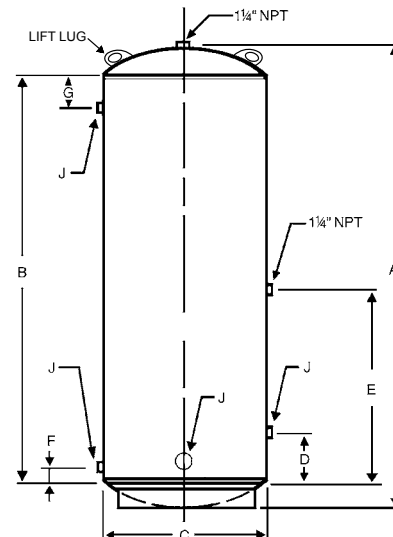

PRESSURE RELIEF VALVE

ONLY FOR INSTALLATION ON PUMP TANK OR EXPANSION TANK SYSTEMS

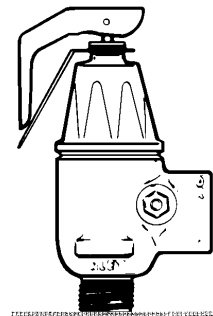
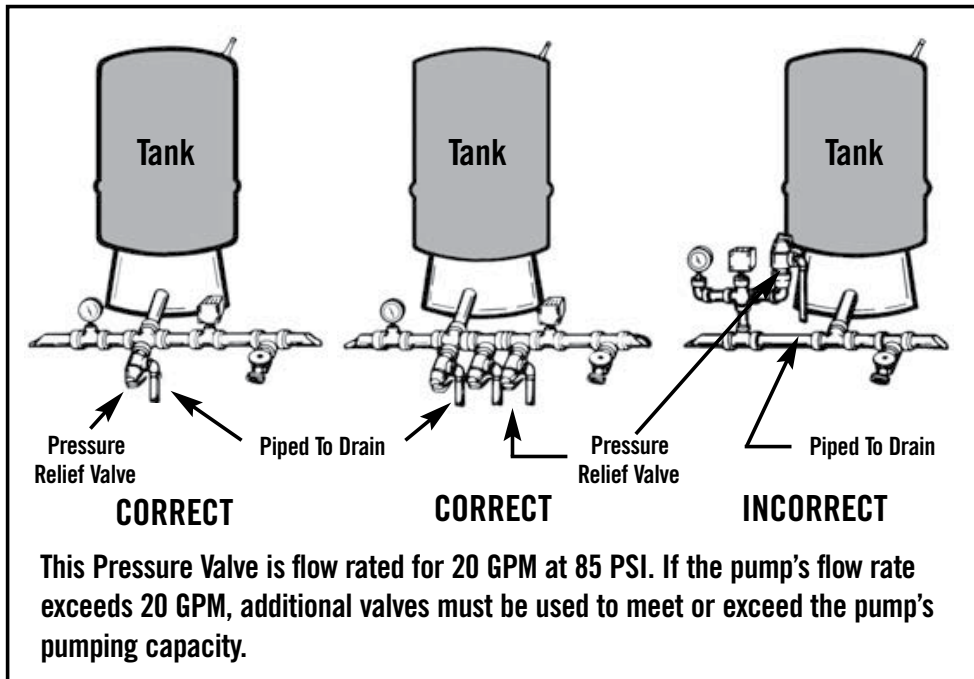

- 75 pound setting
- 20 GPM at 85 PSI
- 3/4" male inlet size
- 3/4" female outlet size

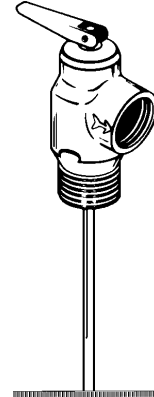

- 100 pound setting
- 20 GPM at 85 PSI
- 3/4" male inlet size
- 3/4" female outlet size

In keeping with our policy of continuous product improvements, we reserve the right to make minor changes without prior notice.