



# COMMERCIAL-GRADE RESIDENTIAL GAS WATER HEATERS

## PROLINE® XE POWER DIRECT VENT COMMERCIAL-GRADE RESIDENTIAL

The ProLine® XE Power Direct Vent water heaters have been engineered to maximize efficiency and deliver a greater energy factor (EF).

### POWER DIRECT VENT DESIGN

- Combined horizontal and vertical vent runs up to 180 equivalent feet with 4" diameter venting (ABS, PVC, CPVC and polypropylene)
- Two-pipe sealed combustion system uses outside air, eliminating problems caused by insufficient indoor ventilation
- Reduced NOx emissions comply with air quality management district regulations

### ENERGY STAR® QUALIFIED

- All models (except GS6 75 YRPDTL) meet the ENERGY STAR® EF requirement and may also qualify for local utility and rebate programs
- Built-in heat traps on the water inlet and outlet reduce the amount of heat lost through piping
- 2-inch thick, "Environmentally-Friendly" foam insulation reduces the amount of heat loss and contributes to overall energy efficiency

### SELF-CLEANING DIP TUBE

- Helps reduce lime and sediment buildup and maximizes hot water output. Made from long-lasting PEX cross-linked polymer.

### HOT-SURFACE IGNITOR

- More robust and reliable than standing pilot, and reduces energy consumption.

### BLUE DIAMOND® GLASS COATING

- Provides superior corrosion resistance compared to the industry-standard glasslining.

### USER-FRIENDLY

- State-of-the-art electronic gas control provides more precise temperature control
- LED control light displays operation status and diagnostics information
- Built-in heat traps on the water inlet and outlet reduce the amount of heat lost through piping

### ENHANCED-FLOW BRASS DRAIN VALVE

- Our residential water heaters have a solid brass, tamper resistant, enhanced-flow, ball type, drain valve.
- Uses a standard female hose fitting that allows for fast and easy draining during maintenance.
- Designed for easy operation, this valve includes an integral screwdriver slot that features a ¼ turn (open/close) radius, which not only permits full straight-through water flow but also a quick and positive shut off.

### CSA CERTIFIED AND ASME RATED T&P RELIEF VALVE

### DESIGN-CERTIFIED BY CSA INTERNATIONAL

- Certified at 150 psi working pressure.
- Certified to ANSI Z21.10.1-CSA 4.1 or ANSI Z21.10.3-CSA 4.3 standards governing storage tank-type water heaters.

### AVAILABLE IN NATURAL GAS AND PROPANE

### 6-YEAR LIMITED TANK AND PARTS WARRANTY



(EXCEPT GS6 75 YRPDTL)



# SOLID. STATE.



# COMMERCIAL-GRADE

## RESIDENTIAL GAS WATER HEATERS

Model Number	Series	Gallon Capacity	Input BTU/h	Energy Factor	First Hour Rating Gallon	Recovery @ 90°F Rise Gallon Per Hour	Dimensions in Inches								Approx. Shipping Weight (lbs)
							A	B	C	D	E	F	G	H	
GS6 40 YBPDS	200	40	40,000	0.71	71	45.2	58-1/4	49-5/8	22	29-7/8	11	13-1/4	42-1/2	15-1/4	174
GS6 50 YBPDT	200	50	45,000	0.70	93	50.3	67-1/2	58-3/4	22	29-7/8	11	13-1/4	51-3/4	15-1/4	192
GS6 50 YRPDTL 5	200	50	62,000*	0.71	115	72.6	69	60-1/4	22	29-7/8	11	13-1/4	52-3/4	15-1/4	200
†GS6 75 YRPDTL	210	75	76,000	N/A	N/A	82.4	70-5/8	61-1/2	26	33-7/8	11	13-1/4	53	15-1/4	277

\*Propane model has input of 58,000 BTU/hr.  
 When ordering propane (LP), change "Y" to "H" in the model number (example GS6 40 YBPDSL).  
 For side connect models, add 'L' to model number, e.g. GPDH 50L.  
 Side connections available on YBPDS and YBPDT models.  
 Side connections are standard on YRPDTL models.  
 Natural gas models cited are series 200/210. Propane models are series 201/211.  
 All models rated for installation at altitudes up to 10,100 ft.  
 †GS6 75 YRPDTL is not ENERGY STAR® qualified.

### Vent Length

Model Number	Maximum Vent Length Eq. Ft.		
	Ø2"	Ø3"	Ø4"
GS6 40 YBPDS	50'	125'	180'
GS6 50 YBPDT	50'	125'	180'
GS6 50 YRPDTL 5	N/A	50'	125'
GS6 75 YRPDTL 5	N/A	50'	125'

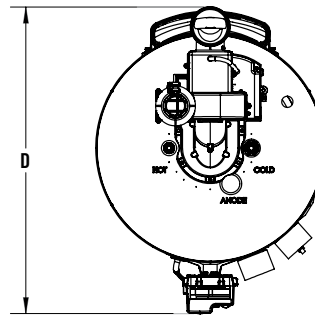

### Optional Vent Kits

Description	Part Number
2" Vent Kit- Coupling, sound suppressor	330828-000
3" Vent Kit- Coupling, sound suppressor	330851-000
2" Concentric Vent Kit	9008586005
3" Concentric Vent Kit	9006328005
Hi Ambient Kit	9009024015

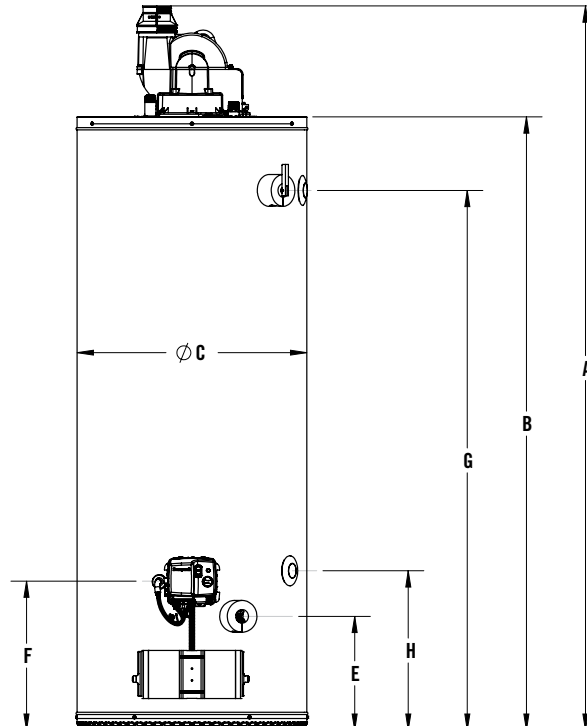

FOR MORE INFORMATION CONTACT: STATE WATER HEATERS 500 TENNESSEE WALTZ PARKWAY, ASHLAND CITY, TN 37015 • 800-365-0024 TOLL-FREE USA • STATEWATERHEATERS.COM