

SELECT® ULTRA-LOW NOX RESIDENTIAL GAS WATER HEATERS



**Image Shows
Model GS675 URRBS**



Low Lead Content



FEATURES

The GS6-75 residential gas water heater meets Air Quality Management District Requirements for NO_x emissions of 14 ng/j or 20 ppm. This model is equipped with a prewired, factory-mounted blower. This blower provides more efficient control of heat and helps ensure an adequate supply of make-up air. Prior to ignition, the control proves a working draft.

Factory-Installed Blower

- Control proves draft prior to ignition
- No draft hood or barometric damper required
- Blower is factory-mounted with a 6-foot power cord: requires 120V, 3 amp or less electrical system connection

Intelli-Vent™ Gas Control

- Equipped with nearly indestructible silicon nitride hot surface ignitor
- Advanced electronics for precise control of water temperature
- Easy-to-understand system diagnostics

Rated as Category I Appliance

- Category I appliance: uses standard metal, single-wall or "B" type vent
- May be common vented with other Category I appliances
- Vent connects directly to blower outlet

Fully Automatic Control System

- Auto-reset gas shutoff device prevents excessive water temperature
- Adjustable thermostat with 120°F-160°F range
- Gas pressure regulator

Glasslined Tank

- Anode rods with stainless steel core provides additional corrosion protection

Side Loop Connections

- This model comes standard with side loop connections for optional hydronic heating loop applications

CSA Certified and ASME Rated T&P Relief Valve

Maximum Hydrostatic Working Pressure: 150 PSI

80% Thermal Efficiency

Codes and Standards

- Design-certified according to ANSI Z21.10.3-CSA 4.3 standards governing storage-type water heaters
- California Energy Commission
- Meets the thermal efficiency and standby loss requirements of the U.S. Department of Energy and current edition of ASHRAE/IESNA 90.1
- Design-certified by Underwriters Laboratories
- Certified for use on combustible flooring
- Complies with SCAQMD Rule 1146.2 and other Air Quality Management Districts with similar requirements of 14 ng/j or 20 ppm

Six Year Limited Tank and Parts Warranty

- For complete warranty information, consult written warranty

Intelli-Vent™ is a registered trademark of Emerson Electric Company

For more information on Ultra-Low NO_x, contact:

State Water Heaters
500 Tennessee Waltz Parkway
Ashland City, TN 37015
800-365-0024 Toll-free USA
www.statewaterheaters.com

SOLID.STATE.



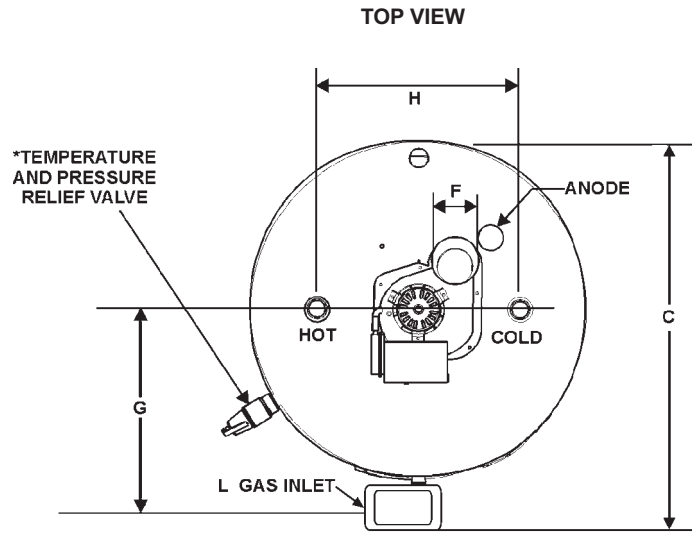
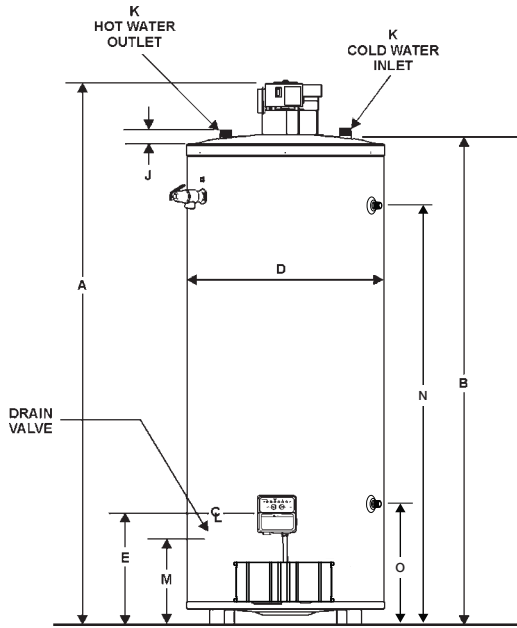

*INSTALL IN ACCORDANCE WITH LOCAL CODES

Model	Gallon Capacity	BTU Input Per Hour Natural	BTU Output Per Hour Natural	Recovery 90°F Rise Gallons Per Hour	Dimensions in Inches													Approximate Shipping Weight (LBS)	
					A	B	C	D	E	F	G	H	J	K	L	M	N		O
GS675 URRBS	74	75,100	60,080	81	65-7/8	57-7/8	30-15/16	25-1/4	15-1/2	4	15-3/8	16	2-1/4	1	1/2	12-1/4	51	16-1/4	300

This model is not FVIR compliant.
Supplied with side loop connections standard.

SAMPLE SPECIFICATION

Natural gas water heater(s) shall be State _____ or equal, with a storage capacity of _____ gallons, an input rating of _____ BTUs per hour, a recovery rating of _____ GPH at 90°F rise and a maximum hydrostatic working pressure of _____ psi. Water heaters(s) shall be supplied with a factory-installed blower and 6-foot power cord; control will prove draft prior to ignition. Glasslined water heater(s) shall also be protected against electrolytic corrosion by a factory-installed State anode rod. In addition, water heater(s) shall be equipped with: 1) An Intelli-Vent™ gas control system with silicon nitride hot surface ignitor, advanced electronics for more precise control of water temperature and easy-to-understand system diagnostics. 2) An auto-reset gas shutoff device, a gas pressure regulator, CSA Certified and ASME rated T&P relief valve. 3) Certification by Underwriters Laboratories under Volume III tests for water heaters. 4) Design certification according to ANSI Z21.10.3 - CSA 4.3 standards governing storage-type water heaters. 5) Meets the thermal efficiency and standby loss requirements of the U.S. Department of Energy and current edition of ASHRAE/IESNA 90.1 and meets Ultra-low NOx emissions of 14 ng/j or 20 ppm. 6) Have a 6-year limited tank and parts warranty against corrosion as outlined in the written warranty.

For complete information on limited warranties, consult written warranty or contact the State Customer Care Center at 1-800-365-0024.

State Industries, Inc., reserves the right to make product changes or improvements without prior notice.

For more information on Ultra-Low NOx, contact:

State Water Heaters
500 Tennessee Waltz Parkway
Ashland City, TN 37015
800-365-0024 Toll-free USA
www.statewaterheaters.com

SOLID.STATE.

