

RESIDENTIAL GAS HYBRID WATER HEATER



GPH-90N



ANSI Z21.10.3



CSA 4.3



Low Lead Content

The Premier® Hybrid water heater is the latest in cutting edge technology from State Water Heaters that combines the best attributes of conventional and tankless technology to provide the best of both worlds

FEATURES

Energy Efficient

- Patented circulation system delivers 90% thermal efficiency, ensuring maximum heat transfer, saving money on operating costs compared to a standard 78% efficient conventional or 84% tankless gas water heaters.
- Condensing design includes condensate drain trap

Hybrid Technology

- Innovative technology that surpasses existing conventional and tankless designs
- Patented water flow circulation system provides the performance of a tankless unit with extremely quick recovery
- Smaller than a conventional 50-gallon gas water heater, but with twice the hot water delivery
- Whole-home solution regardless of geography

Improved Hot Water Delivery

- Continuous hot water shower after shower when properly sized for your home
- No minimum flow rate for ignition
- No cold water sandwich
- Delivers hot water faster than tankless
- Internal storage easily handles peak demand

Sophisticated Electronics

- User-friendly integrated temperature controller with LED numeric display allows for precise temperature settings
- Multiple Lifestyle Modes - Energy Saver, Vacation and Boost modes allow for simple one-touch customization based on specific hot water needs
- Safety lock feature deters unwanted access
- Error code display for easy troubleshooting

Lower Installation Costs

- Utilizes 1/2" gas line standard in most homes today
- Extremely low exhaust temperature enables PVC venting for easier, more economical installations
- Less expensive venting material versus stainless steel venting used with most tankless models
- Hot and cold water connections similar to conventional tank-style models

Power Vent Design

- Uses inexpensive PVC, CPVC or ABS pipe for venting (solid core only)
- Can be vented vertically thru-the-roof or horizontally thru-the-wall
- 2" pipe vents up to 50 equivalent feet
- 3" pipe vents up to 100 equivalent feet

Six Year Limited Warranty on Heat Exchanger, Tank and Parts

- For complete information, consult written warranty or contact State Customer Care Center.

For more information on Hybrid, contact:

State Water Heaters
500 Tennessee Waltz Parkway
Ashland City, TN 37015
800-365-0024 Toll-free USA
www.statewaterheaters.com

SOLID.STATE.



RESIDENTIAL GAS HYBRID WATER HEATER

MODEL NUMBER	RECOVERY 90°F RISE GALLONS	INPUT	MANIFOLD PRESSURE			ELECTRICAL CHARACTERISTICS		SHIPPING WEIGHT LBS/KGS
		BTU/HR	GAS TYPE	IN. WC	KPA	VOLTS/HZ	AMPERES	
GPH-90N	121	100,000	NAT	4.2	1.05	120/60	2.5	198/90

This gas-fired water heater is design certified by CSA International under American National Standard/CSA Standard for Gas Water Heaters ANSI Z21.10.3 • CSA 4.3 (current edition).

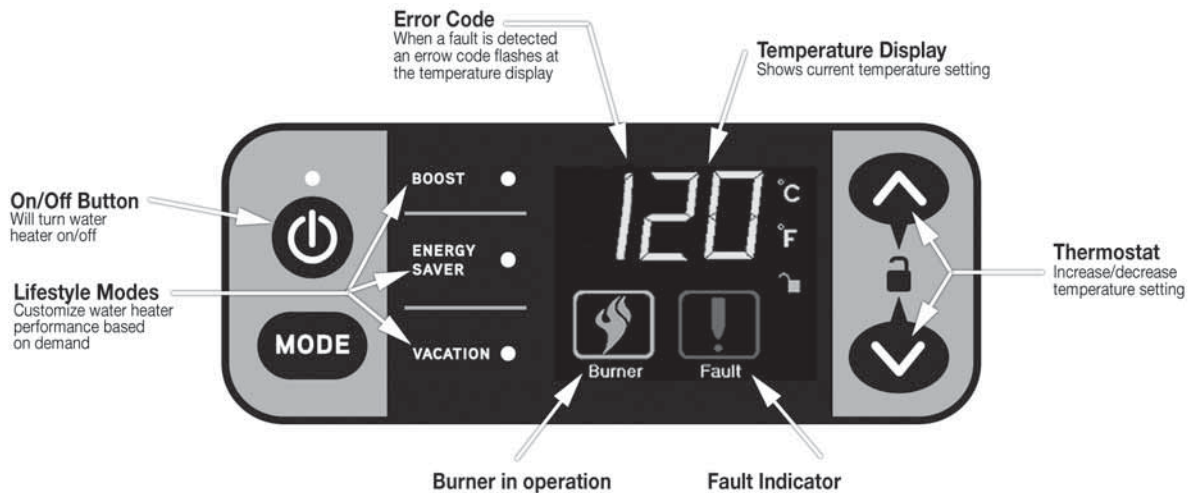
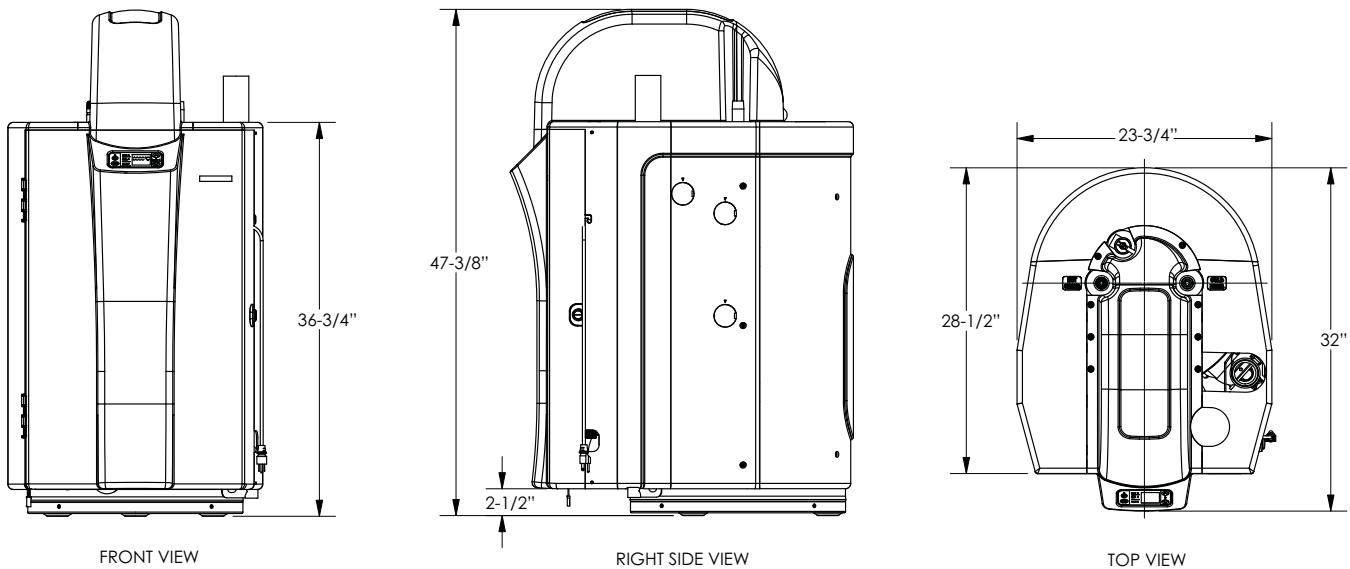

For complete information on limited warranties, consult written warranty or contact the State Customer Care Center at 1-800-365-0024.

State Industries, Inc., reserves the right to make product changes or improvements without prior notice.

For more information on Hybrid, contact:

State Water Heaters
500 Tennessee Waltz Parkway
Ashland City, TN 37015
800-365-0024 Toll-free USA
www.statewaterheaters.com

SOLID.STATE.



SRYS00110 Revised May 2012