



FULL PRODUCT LINE
POCKET GUIDE
RESIDENTIAL & COMMERCIAL



TABLE OF CONTENTS

Introducing the ProLine® Family.....	4
Contractor Rewards.....	5
ProLine® Gas Family Features	6
ProLine® Electric Family Features	7
ProLine® Tankless Family Features.....	8
Benefits.....	9

RESIDENTIAL GAS

Premier® High Efficiency Power Vent	10-11
Premier® High Efficiency Power Direct Vent.....	12-13
Polaris™ High Efficiency.....	14-15
ProLine® XE Power Vent.....	16-17
ProLine® XE Non-Condensing Power Direct Vent.....	18-19
ProLine® XE Non-Condensing Flue Damper	20-21
ProLine® XE Non-Condensing Ultra-Low NOx Flue Damper	22-23
ProLine® XE Ultra-Low NOx Power Vent.....	24-25
ProLine® Master Atmospheric Vent.....	26-27
ProLine® Master Ultra-Low NOx.....	28-29
ProLine® High Capacity Atmospheric Vent.....	30-31
ProLine® Direct Vent.....	32-33
ProLine® Atmospheric Vent.....	34-37
ProLine® Mobile Home Atmospheric Vent.....	38-39
ProLine® Mobile Home Direct Vent.....	40-41
ProLine® Ultra-Low NOx.....	42-43
ProLine® Ultra-Low NOx Direct Vent.....	44-45
ProLine® Ultra-Low NOx High Capacity.....	46-47

RESIDENTIAL HYBRID ELECTRIC

Premier® AL Smart Hybrid Electric Heat Pump	48-49
ProLine® XE Hybrid Electric Heat Pump - 10-Year Warranty	50-51
ProLine® XE Hybrid Electric Heat Pump - 6-Year Warranty	52-53

RESIDENTIAL ELECTRIC

ProLine® Master Smart Electric	54-55
ProLine® Master Electric Grid-Capable	56-57
ProLine® Master	58-59
ProLine® Grid-Capable.....	60-61
ProLine® Standard	62-63
Mobile Home.....	64-65
ProLine® Specialty.....	66-67

COMMERCIAL & RESIDENTIAL PUMP AND EXPANSION TANKS

Pump Mate™	68-69
Heavy-Duty State ProLine® Glasslined G Series	70-71
Heavy-Duty State ProLine® Galvanized Z Series.....	72-73
Waterguard™ & Therm-o-Flex™	74-75
Therm-o-Flex™	76-77

TABLE OF CONTENTS

TANKLESS

ProLine® XE Condensing with X3 Scale Prevention Technology.....	78-79
ProLine® XE Condensing with Recirculation Pump.....	80-81
ProLine® XE Condensing High Efficiency 140.....	82-83
ProLine® XE Condensing High Efficiency 240-540.....	84-85
ProLine® XE Non-Condensing Concentric Vent.....	86-87
Tankless Non-Condensing Ultra-Low Nox.....	88-89
Tankless Non-Condensing Heavy-Duty.....	90-91
ProLine® XE Combi Boiler.....	92-93
Tankless Commercial Rack System.....	94-97
BACnet and Modbus Interface.....	98-99
Electric Tankless.....	100-101

COMMERCIAL GAS AND OIL FIRED

Force® 90 Power Vent.....	102-103
Force® 90+ Power Direct Vent 50 Gal.....	104-105
Force® 90+ Power Direct Vent 75 Gal.....	106-107
Modulating Ultra Force®.....	108-111
Ultra Force™ XL.....	112-113
Ultra Force™ LV.....	114-117
Polaris™ High Efficiency.....	118-119
TX1 Integrated Tankless on Tank.....	120-121
Sandblaster® Self Cleaning - SBD Series.....	122-125
Sandblaster® Ultra-Low NOx.....	126-129
Sandblaster® - SBS Series.....	130-131
Sandblaster® Light-Duty.....	132-133
Force® Power Direct Vent.....	134-135
Sandblaster® Low NOx Single Flue.....	136-137
State Titan® Power Gas Burner.....	138-139
State Titan® Low NOx Power Gas Burner.....	140-141
State Titan® LV Power Gas Heavy-Duty TPG.....	142-145
State Titan® Power Burner GPO Series Oil.....	146-147

COMMERCIAL ELECTRIC

Patriot™ Light-Service Electric.....	148-149
Patriot™ Light-Duty Electric.....	150-151
Sandblaster® Immersion Mount Thermostat - CSB Series.....	152-153
Sandblaster® Surface Mount Thermostat - CSB Series.....	154-155
Statesman™ Premium Heavy-Duty Electric - SSE Series.....	156-157

COMMERCIAL HEAT PUMP

CHP-120 Fully Integrated Heat Pump.....	158-159
---	---------

COMMERCIAL STORAGE TANKS

Standard Jacketed Storage Tanks.....	160-161
Custom-Line Factory Jacketed & Insulated Storage Tanks.....	162-165
Uninsulated Standard Stock Bare.....	166-167
Heavy-Duty Large Volume Storage Tanks.....	168-171

There's
nothing
standard
about
commercial
grade.



When it comes to providing durable and reliable hot water, the State ProLine family of products removes the line between what goes in a commercial water heater and a residential unit. We draw from our expertise in commercial water heating, house-made components, and rigorous quality and endurance testing to ensure that your customer's water heater is built to overperform no matter where it's installed.

WHY PROFESSIONALS CHOOSE STATE



**CONTRACTOR
REWARDS.COM**
Your Business. Your Choices. Your Rewards.

EARN POINTS BY PURCHASING STATE WATER HEATERS

It's free and easy to participate. Enroll online at contractorrewards.com. Eligible products will have a yellow reward code label worth valuable points. Two ways to enter the codes:

1. Download the smartphone app and scan the code.
2. Enter the code at contractorrewards.com.
3. Redeem your points on thousands of reward items.

**WITH OVER 1,000,000
MERCHANDISE ITEMS,
YOUR REWARD CHOICES
ARE ENDLESS.**

STATE PROVIDES 6 KEY THINGS

TO HELP GROW YOUR BUSINESS & BECOME MORE PROFITABLE



1. Contractor Locator: A new online locator that drives thousands of consumers from our website right to our loyal contractors. Your company listing is free and generated for you when you participate in our Contractor Rewards™ program.* Visit statewaterheaters.com/contractorlocator for more information.

2. Contractor Rewards Program: Our program rewards our loyal contractors for buying our products. Buy more and get rewarded with prizes and higher status on our Contractor Locator.

3. Contractor Advertising Tools: Our Advertising Resource Center allows contractors to develop an easy, affordable and custom advertising campaign to promote their business. Go to www.statewaterheaters.com/ads.

4. Breadth of Product Line: Residential or commercial, we have the most complete line from standard models to the most innovative high efficiency water heaters available.

5. Product Sales Tools: We provide contractors access to the sales tools needed to close more sales.

6. Brand Support: Marketing investment in our brand drives consumers to recognize our name, visit our website, locate local contractors and request products.

*To be listed on the Contractor Locator you must meet the minimum threshold of codes entered at contractorrewards.com

Visit statewaterheaters.com/contractor to learn more.

An in-depth look at the commercial-grade features available in our residential ProLine family

PREMIUM FEATURES:

ProLine®

ProLine®
Master

ProLine® XE

Gas Water Heaters



OPERATING COST
INSTALLATION SPACE
REQUIRED
WARRANTY (YEARS)

\$\$\$



6

\$\$;



8

\$



10

Commercial-Grade Components

Blue Diamond®
Glass Lining

•

•

•

DynaClean™
Automatic Sediment-
Cleaning System

•

•

•

Electronic Gas Valve

•

•

•

Heat Trap Nipples

•

•

•

Enhanced Flow
Brass Drain Valve

•

•

•

CoreGard™ Anode
Rod Protection

•

•

•

Advanced Anode Protection

•

•

Extended Warranty
Kit Available

•

•

•*

Electronic User Interface

•*

•

High Efficiency
Performance

•

ENERGY STAR® Qualified

•*

Best-In-Class Material
and Technology

•

Industry-Leading
Efficiency

•

Flexible Venting for
more Install Options

•

*Some Models Not Eligible

Benefits that homeowners love

An in-depth look at the commercial-grade features available in our residential ProLine family

PREMIUM FEATURES:

ProLine®

*ProLine®
Master*

ProLine® XE

Electric Water Heaters



OPERATING COST
INSTALLATION SPACE
REQUIRED
WARRANTY (YEARS)

\$\$\$



6

\$\$;



8

\$



10

Blue Diamond® Glass Lining	●	●	●
DynaClean™ Automatic Sediment-Cleaning System	●	●	●
Heat Trap Nipples	●	●	●
Enhanced Flow Brass Drain Valve	●	●	●
CoreGard™ Anode Rod Protection	●	●	●
Advanced Anode Protection		●	●
Stainless Steel Upper Element	●	●	
Dual Stainless Steel Element		●	●
Extended Warranty Kit Available	●	●	●*
Electronic User Interface		●*	●
iCOMM® Remote Connectivity		●*	●
ENERGY STAR® Qualified			●
Industry-Leading Efficiency			●
Best-In-Class Material and Technology			●

*Some Models Not Eligible

Commercial-Grade Components

Benefits that homeowners love

An in-depth look at the commercial-grade features available in our residential ProLine family

PREMIUM FEATURES:

ProLine® XE

Tankless Water Heaters

OPERATING COST \$
 INSTALLATION SPACE REQUIRED ■
 WARRANTY (YEARS) 6-10



Model Family	Proline XE With X3® Technology	Proline XE Non-Condensing ULN	Proline XE Non-Condensing Concentric Vent
Condensing	●	●	●
Non-Condensing		●	●
Indoor Models	●	●	●
Outdoor Models	●	●	
BTUs	160K-190K	140K-199K	140K-199K
X3® Scale Prevention Technology	●		
Concentric Venting			●
Ultra-Low Nox	●	●	
ENERGY STAR® Qualified	●*		

Model Family	Proline XE Condensing	Proline XE Condensing with Recirc Pump	Proline XE Combi Boiler
Condensing	●	●	●
Indoor Models	●	●	●
Outdoor Models	●	●	
BTUs	120K-199K	199K	110K-199K
Recirculation Pump - DHW		●	
Recirculation Pump - Hydronic Heating			●
Ultra-Low Nox	●	●	●
ENERGY STAR® Qualified	●*	●*	●

*Some Models Not Eligible

TOUGHER

COMPONENTS.

LONGER

PERFORMANCE.



Blue Diamond® Glass Coating



Stainless Steel Core Anode Rods



DynaClean™ Automatic Sediment Cleaning System



Longer-Lasting Stainless Steel Elements

THERE'S NOTHING STANDARD ABOUT OUR COMMERCIAL GRADE PROLINE®.

Learn more at statewaterheaters.com



Blue Diamond® Glass Coating

State residential gas and electric water heaters have the toughest protection against corrosion to maximize tank life.

State's Blue Diamond® Glass Coating provides superior corrosion resistance compared to the industry-standard glass lining.



Green Choice® Gas Burner

Patented eco-friendly burner design reduces NOx emissions by up to 33% and complies with Low-NOx emission requirements of less than 40 ng/l.



LOW LEAD CONTENT

CSA low lead logo on a plumbing product signifies certification to California's AB1953 and Vermont's legislation Act 193 that limits the lead content in plumbing fixtures that come in contact with drinking water to a maximum of 0.25% lead.



ENERGY STAR®

State Water Heaters offers a variety of models that are ENERGY STAR® qualified. Learn more at www.energystar.gov.



CoreGard™ Anode Rod

Our anode rods have a stainless steel core that extends the life of the anode rod, allowing superior tank protection far longer than standard anode rods.



Enhanced-Flow Brass Drain Valve

Our residential water heaters have a solid brass, tamper resistant, enhanced-flow, ball type drain valve.

- Uses a standard female hose fitting that allows for fast and easy draining during maintenance.
- Designed for easy operation, this valve includes an integral screwdriver slot that features a 1/4 turn (open/close) radius, which not only permits full straight-through water flow but also a quick and positive shut off.



Self-Cleaning Systems on State Residential Models

Automatic self-cleaning action greatly reduces lime and sediment buildup, maximizes hot water output. Made from long-lasting Pex cross-linked polymer.

Our ProLine® XE models come standard with maximum sediment-fighting power and utilize our top-of-the-line Turbo Coil design.



Heat Trap Nipples

Factory-installed for faster installation on most State residential models.

PREMIER® HIGH EFFICIENCY POWER VENT

PROLINE® XE
BEST



GAS-FIRED



Low Carbon Content



POWER VENT DESIGN FOR INSTALLATION VERSATILITY

- Helical internal heat exchanger achieves 90% thermal efficiency, which saves money on operating costs compared to a standard 80% efficient gas water heater
- Combined horizontal and vertical vent runs terminating through outside wall, using Schedule 40 PVC pipe as follows:
 - 2" pipe allows vent runs up to 25 equivalent feet
 - 3" pipe allows vent runs up to 65 equivalent feet
 - 4" pipe allows vent runs up to 128 equivalent feet

SIDE-MOUNTED TAPS FOR RECIRCULATING SYSTEMS

- Hot and cold "side taps" allow Premier Power Vent to be used for combination space/water heating applications

INTELLI-VENT™* GAS CONTROL WITH SILICON NITRIDE HOT SURFACE IGNITOR

- Premium-grade hot surface ignitor eliminates standing pilot
- Electronic circuitry provides superior system diagnostic capabilities plus extremely precise temperature control

BLUE DIAMOND® GLASS COATING WITH TWO HEAVY DUTY ANODE RODS

- Provides superior corrosion resistance compared to the industry-standard glass lining

GREEN CHOICE® GAS BURNER

- Patented eco-friendly burner design reduces NOx emissions by up to 33% and complies with Low-NOx emission requirements of less than 40 ng/J

SELF-CLEANING DIP TUBE

CSA CERTIFIED AND ASME RATED T&P RELIEF VALVE

MAXIMUM HYDROSTATIC WORKING PRESSURE: 150 PSI

CODE COMPLIANCE

- Meets UBC, CEC and ICC National Codes
- Meets the thermal efficiency and standby loss requirements of the U.S. Department of Energy and Current edition of ASHRAE/IES 90.1

6-YEAR LIMITED TANK AND PARTS WARRANTY

- For complete information, consult written warranty or go to statewaterheaters.com

*Intelli-Vent is a registered trademark of Emerson Electric Company

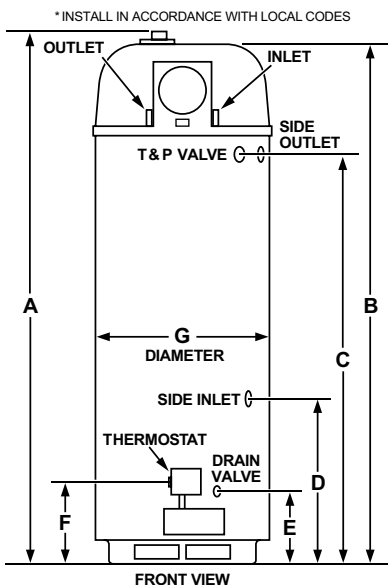
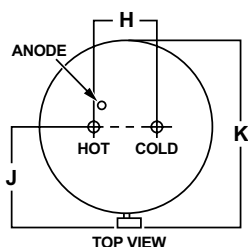

Model Number	Nominal Capacity	Rated Storage Volume	First Hour Rating (Gallons)	UEF	Thermal Efficiency	Recovery @ 90°F Rise Gallon Per Hour	BTU Input Per Hour
GP6-50-YTVIT	50	48	119	0.88	90%	92	76,000

Model Number	Dimensions in Inches										Approx. Shipping Weight (lbs)
	A	B	C	D	E	F	G	H	J	K	
GP6-50-YTVIT	71-1/8	68-5/8	52	21	9-1/8	12	22	8	15-3/4	27	210

Available in natural gas only.

Standard model certified for sea level to 5,300 ft. elevation. Specify high altitude when ordering for use in elevations up to 10,100 ft.

Optional Condensate Neutralizer Kit available (part number 100112380).

PREMIER® HIGH EFFICIENCY POWER DIRECT VENT

PROLINE® XE
BEST



GP6 75 YTPDT



ENERGY STAR® QUALIFIED CONDENSING DESIGN

- Helical internal heat exchanger keeps hot combustion gases in the tank longer to extract more heat into the water
- High efficiency operation with up to 0.88 UEF (96% Thermal Efficiency) which saves money on operating costs compared to a standard efficiency gas water heater

ADVANCED ELECTRONIC CONTROL

- Optional Powered Anode available
- Exclusive State designed touch display control system
- Precise temperature control
- Built-in diagnostics and operational information

POWER DIRECT VENT DESIGN

- Power Direct vent using PVC, CPVC or Polypropylene either thru-the-wall or thru-the-roof
- Optional concentric vent and low profile termination kits are available

ULTRA-LOW NOX

- Complies with SCAQMD Rule 1146.2 and other air quality management districts with similar requirements for Ultra-Low NOx emissions requirements of 14 ng/J or 20 PPM

SIDE-MOUNTED HOT AND COLD RECIRCULATING TAPS

- Hot and cold “side taps” allow Vertex Power Direct Vent to be used for combination space/ water heating applications

CODE COMPLIANCE

- Meets IBC and ICC National Codes
- Meets the thermal efficiency and standby loss requirements of the U. S. Department of Energy and current edition of ASHRAE/IES 90.1

6-YEAR LIMITED TANK AND PARTS WARRANTY

- For complete information, consult written warranty or go to statewaterheaters.com

ROUGH IN DIMENSIONS: 50 GALLON UNIT

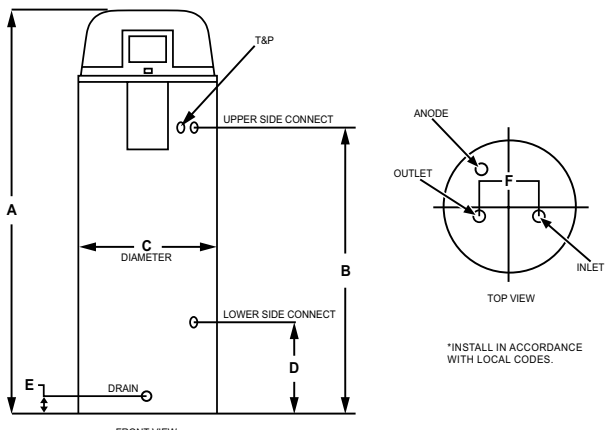

ROUGH IN DIMENSIONS: 75 GALLON UNIT

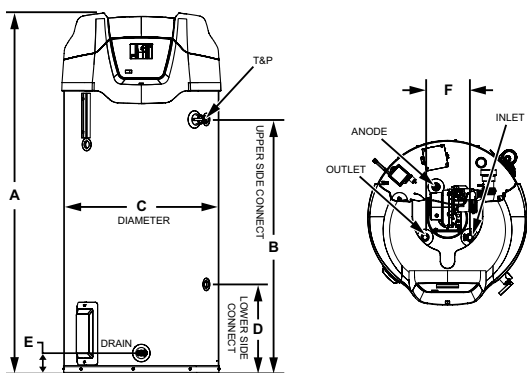

Model Number	Nominal Capacity	Rated Storage Volume	First Hour Rating (Gallons)	UEF	Thermal Efficiency	Recovery @ 90°F/50°C Rise Gallon Per Hour	BTU Input Per Hour	Vent Size
GP6-50-YTPDT	50	49	100	0.88	96%	129 (488)	100,000	2 or 3
GP6-75-YTPDT	75	74	130	0.86	96%	129 (488)	100,000	2 or 3

Model Number	Dimensions in Inches						Approx. Shipping Weight (lbs)
	A	B	C	D	E	F	
GP6-50-YTPDT	66-3/4	49-1/4	22	15-3/4	3	8	255
GP6-75-YTPDT	65-1/4	45-5/8	27-3/4	16	3-3/4	8	382

Available in Propane (LP) gas. Change "Y" to "H" in the model number (example: GP6 50 HTPDT).

Available with a Powered Anode. Specify when ordering.

Models certified from sea level to 10,100 ft. elevation.

Optional Condensate Neutralizer Kit available (Part Number 100112380).

POLARIS™ HIGH EFFICIENCY

PROLINE® XE
BEST



CONDENSING DESIGN

- Operates at up to 96% thermal efficiency which saves money on operating costs compared to a standard 80% efficient gas water heater
- Helical internal heat exchanger keeps hot combustion gases in the tank longer to extract more heat into the water

STAINLESS STEEL CONSTRUCTION

- Tank and helical heat exchanger are constructed from 444 stainless steel for excellent corrosion resistance without the need for an anode

WHISPER QUIET OPERATION

- Ultra-quiet blower and burner minimize noise

POWER DIRECT VENT DESIGN

- Direct vent using PVC, CPVC or ABS either thru-the-wall or thru-the-roof

OPTIONAL CONCENTRIC VENT KIT

ADVANCED ELECTRONIC CONTROL

- Large LCD display provides precise temperature control and advanced diagnostics

CODE COMPLIANCE

- Complies with SCAQMD Rule 1146.2 and other air quality management districts with similar requirements for Ultra-Low NOx emissions requirements of 14 ng/J or 20 PPM
- Meets UBC, CEC, and ICC National Codes
- Meets the thermal efficiency and standby loss requirements of the U. S. Department of Energy and current edition of ASHRAE/IES 90.1.

10-YEAR LIMITED TANK AND 10-YEAR PARTS WARRANTY

- For complete information, consult written warranty or go to statewaterheaters.com

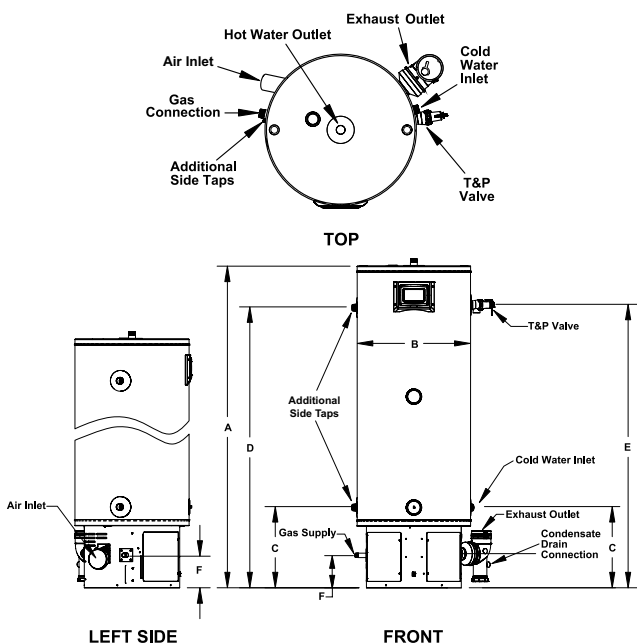

Model Number	Nominal Capacity	Rated Storage Volume	First Hour Rating (Gallons)	UEF	Thermal Efficiency	Recovery @ 90° Rise Gallon Per Hour	BTU/h Input Gallon Per Hour	Approx. Shipping Weight (lbs)
GHX-34-100-N	34	33	170	0.90	96%	129	100,000	150
GHX-34-130-N	34	N/A	N/A	N/A	96%	165	130,000	150
GHX-34-150-N	34	N/A	N/A	N/A	94%	190	150,000	150
GHX-50-130-N	50	N/A	N/A	N/A	95%	165	130,000	176
GHX-50-150-N	50	N/A	N/A	N/A	95%	190	150,000	180
GHX-50-175-N	50	N/A	N/A	N/A	96%	222	175,000	180
GHX-50-199-N	50	N/A	N/A	N/A	96%	253	199,000	180

Model Number	Dimensions in Inches		Vent Connection	1" Water Connections		T&P	Gas Supply*
	A	B		C	D		
GHX-34-100-N	48-1/2	22	2 or 3	15-3/4	40-1/2	41	6-3/8
GHX-34-130-N	48-1/2	22	2 or 3	15-3/4	40-1/2	41	6-3/8
GHX-34-150-N	48-1/2	22	2 or 3	15-3/4	40-1/2	41	6-3/8
GHX-50-130-N	62-3/8	22	2 or 3	15-3/4	54-1/2	55	6-3/8
GHX-50-150-N	63-3/4	22	2 or 3	15-3/4	55-3/4	56-1/4	6-3/8
GHX-50-175-N	63-3/4	22	3	15-3/4	55-3/4	56-1/4	6-3/8
GHX-50-199-N	63-3/4	22	3	15-3/4	55-3/4	56-1/4	6-3/8

For Propane (LP) gas change "N" to "P".
Models certified for sea level to 7,700 ft. elevation.

PROLINE® XE POWER VENT

PROLINE® XE
BEST



AHR CERTIFIED®
www.ahridirectory.org

VERSATILE POWER VENT DESIGN

- All models feature an exclusive 3-position rotatable blower outlet which adds flexibility
- Combined horizontal and vertical vent runs up to 180 equivalent feet with 4" diameter venting (ABS, PVC, CPVC and polypropylene)
- All models are equipped with a protected sensor that detects the presence of flammable vapors and automatically disables the burner to prevent ignition
- Air intake snorkel elevates the inlet location of combustion air to prevent flammable vapors from entering the sealed combustion chamber

HOT SURFACE IGNITOR

- More robust and reliable than standing pilot, and reduces energy consumption

BUILT-IN HEAT TRAPS ON THE WATER INLET AND OUTLET REDUCE THE AMOUNT OF HEAT LOST THROUGH PIPING

THICK, ENVIRONMENTALLY FRIENDLY FOAM INSULATION REDUCES THE AMOUNT OF HEAT LOSS AND CONTRIBUTES TO OVERALL ENERGY EFFICIENCY

USER-FRIENDLY

- State-of-the-art electronic gas control provides more precise temperature control
- LED control light displays operation status and diagnostics information

ENHANCED-FLOW BRASS DRAIN VALVE

AVAILABLE IN NATURAL GAS AND PROPANE

CODE COMPLIANCE:

- Meets UBC, CEC and HUD National Codes
- Meets the thermal efficiency and standby loss requirements of the U.S. Department of Energy and current edition of ASHRAE/IES 90.1
- Complies with the Federal Energy Conservation Standards effective April 16, 2015, in accordance with the Energy Policy and Conservation Act (EPCA) as amended

6-YEAR LIMITED TANK AND PARTS WARRANTY

- For complete information, consult written warranty or go to statewaterheaters.com

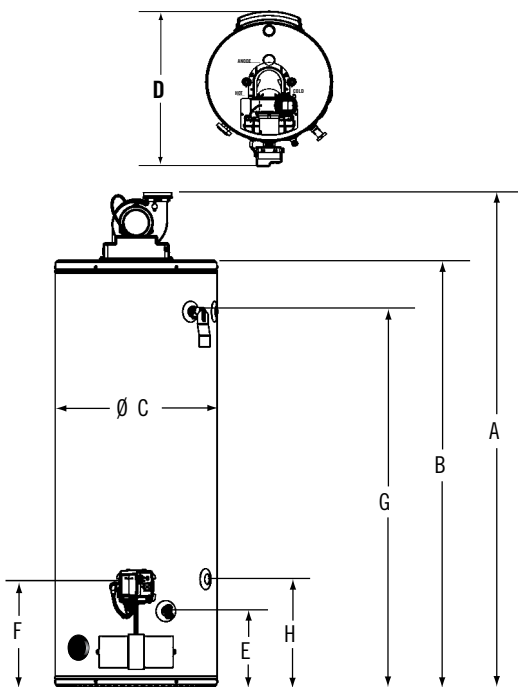

Model Number	Series	Nominal Capacity	Rated Storage Volume	UEF	Recovery @ 90°F Rise Gallon Per Hour	BTU Input Gallon Per Hour	First Hour Rating (Gallons)	Approx. Shipping Weight (lbs)
GS6 40 YBVIS	200	40	38	0.67	45	40,000	72	174
GS6 40 YRVIT	200	40	38	0.70	56	50,000	87	176
GS6 50 YBVIS	200	50	49	0.72	45	40,000	79	198
GS6 50 YRVIT	200	50	48	0.72	56	50,000	97	192
GS6 50 YRVHSL	200	50	50	0.73	69	62,000	119	212
†GS6 75 YRVHTL	310	75	72	0.69	80	76,000	116	277

Model Number	Dimensions in Inches							
	A	B	C	D	E	F	G	H
GS6-40-YBVIS	59	49-5/8	22	29-1/8	11	13-1/4	42-1/2	N/A
GS6-40-YRVIT	68-1/2	59-1/4	20	27-1/8	11	13-1/4	53-1/8	15-1/4
GS6-50-YBVIS	60-1/8	50-3/4	24	31-1/8	11	13-1/4	43-3/4	N/A
GS6-50-YRVIT	68-1/8	58-3/4	22	29-1/8	11	13-1/4	51-3/4	15-1/4
GS6-50-YRVHSL	61-1/8	52	24	31-1/8	11	13-1/4	44-1/2	15-1/4
†GS6-75-YRVHTL	70-5/8	61-1/4	26	33-1/8	11	13-1/4	53	15-1/4

Available in Propane (LP) gas. Change "Y" to "H" in the model number (example: GS6 40 HBVIS).
 Models GS6 50 YRVHSL and GS6 75 YRVHTL come from the factory standard with side loop fittings.
 YRVIT models available with side connections for use in combination applications.
 All models are certified from 10,100 ft. elevation.

PROLINE® XE NON-CONDENSING POWER DIRECT VENT

PROLINE® XE
BEST



AHRI CERTIFIED
www.ahridirectory.org

POWER DIRECT VENT DESIGN

- Combined horizontal and vertical vent runs up to 180 equivalent feet with 4" diameter venting (ABS, PVC, CPVC and polypropylene)
- Two-pipe sealed combustion system uses outside air, eliminating problems caused by insufficient indoor ventilation

GREEN CHOICE® GAS BURNER

- Patented eco-friendly gas burner design reduces NOx and complies with Low-NOx emission requirements of less than 40 ng/J

HOT-SURFACE IGNITOR

- More robust and reliable than standing pilot, and reduces energy consumption

SELF-CLEANING DIP TUBE

USER-FRIENDLY

- State-of-the-art electronic gas control provides more precise temperature control
- LED control light displays operation status and diagnostics information

ENHANCED-FLOW BRASS DRAIN VALVE

CSA CERTIFIED AND ASME RATED T&P RELIEF VALVE

CODE COMPLIANCE:

- Meets UBC, CEC and HUD National Codes
- Meets the thermal efficiency and standby loss requirements of the U.S. Department of Energy and current edition of ASHRAE/IES 90.1
- Complies with the Federal Energy Conservation Standards effective April 16, 2015, in accordance with the Energy Policy and Conservation Act (EPCA) as amended

DESIGN-LISTED BY CSA INTERNATIONAL

- Certified at 300 psi test pressure and 150 psi working pressure
- Listed according to ANSI Z21. Z21.10.1-CSA 4.1 standards governing storage tank-type water heaters

6-YEAR LIMITED TANK AND PARTS WARRANTY

- For complete information, consult written warranty or go to statewaterheaters.com

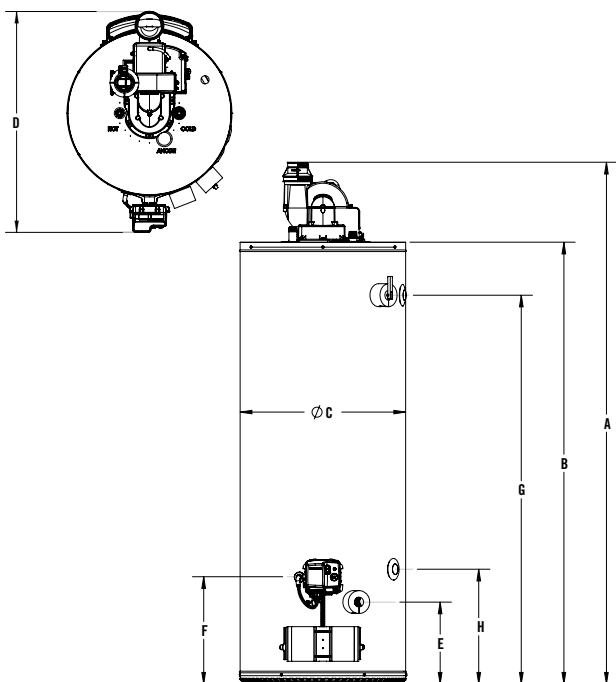

Model Number	Nominal Capacity	Rated Storage Volume	First Hour Rating (Gallons)	UEF	Input BTU/h	Recovery @ 90°F Rise Gallon Per Hour	Approx. Shipping Weight (lb)
GS6-40-YBPDS	40	38	74	0.68	40,000	45	174
GS6-50-YBPDT	50	48	81	0.72	45,000	50	192
GS6-50-YRPDTL-5	50	48	118	0.73	62,000**	73	200
†GS6-75-YRPDTL	75	72	129	0.68	76,000	82	277

Model Number	Dimensions in Inches							
	A	B	C	D	E	F	G	H
GS6-40-YBPDS	58-1/4	49-5/8	22	29-7/8	11	13-1/4	42-1/2	15-1/4
GS6-50-YBPDT	67-1/2	58-3/4	22	29-7/8	11	13-1/4	51-3/4	15-1/4
GS6-50-YRPDTL-5	69	60-1/4	22	29-7/8	11	13-1/4	52-3/4	15-1/4
†GS6-75-YRPDTL	70-5/8	61-1/2	26	33-7/8	11	13-1/4	53	15-1/4

* Propane model has input of 58,000 BTU/hr.

Available in Propane (LP) gas. Specify when ordering Propane (LP) gas.

Side connections standard on GS6 50 YRPDTL5 & GS6 75 YRPDTL models

Side connections available on YBPDS and YBPDT models.

All models are certified from sea level to 10,100 ft. elevation.

PROLINE® XE NON-CONDENSING FLUE DAMPER

PROLINE® XE
BEST



AUTOMATIC FLUE DAMPER

- Increases efficiency as it automatically opens and closes to reduce heat loss in the standby mode

ELECTRONIC GAS CONTROL

DIAGNOSTICS

ELECTRONIC IGNITION

SELF-CLEANING DIP TUBE

GREEN CHOICE® GAS BURNER

- Patented eco-friendly burner design reduces NOx emissions by up to 33% and complies with Low-NOx emission requirements of less than 40 ng/J

COREGARD™ ANODE ROD

ENHANCED-FLOW BRASS DRAIN VALVE

BLUE DIAMOND® GLASS COATING

CSA CERTIFIED AND ASME RATED T&P RELIEF VALVE

CODE COMPLIANCE

- Meets UBC, CEC and HUD National Codes
- Meets the thermal efficiency and standby loss requirements of the U.S. Department of Energy and current edition of ASHRAE/IES 90.1
- Complies with the Federal Energy Conservation Standards effective April 16, 2015, in accordance with the Energy Policy and Conservation Act, (EPCA), as amended

DESIGN-CERTIFIED BY CSA INTERNATIONAL

- Certified at 300 psi test pressure and 150 psi working pressure
- Listed according to ANSI Z21.10.1 - CSA 4.1 standards governing storage tank-type water heaters

6-YEAR LIMITED TANK AND PARTS WARRANTY

- For complete information, consult written warranty or go to statewaterheaters.com

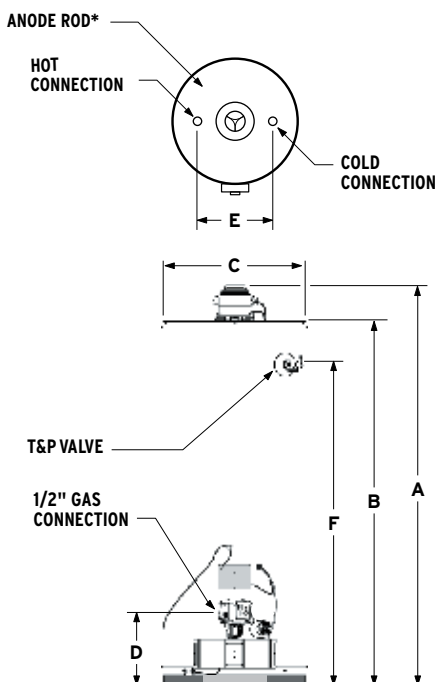

Model Number	Nominal Capacity	Rated Storage Volume	First Hour Rating (Gallons)	UEF	BTU Input Gallon Per Hour Natural*	Recovery @ 90°F Rise Gallon Per Hour	Approx. Shipping Weight (lbs)
Tall Models							
GS6-40-YBFT	40	38	70	0.64	40,000	42	152
GS6-50-YBFT	50	48	84	0.69	40,000	42	167
Short Models							
GS6-40-YBFT	40	38	65	0.66	40,000	42	149
GS6-50-YBFT	50	49	78	0.69	40,000	42	175

Model Number	Dimensions in Inches							Draft Hood Outlet
	Foam Thickness	A	B	C	D	E	F	
Tall Models								
GS6-40-YBFT	2	64-1/4	58-1/4	20	13	8	51-3/4	3 or 4
GS6-50-YBFT	2	63-1/2	57-1/4	22	13	8	50-1/4	3 or 4
Short Models								
GS6-40-YBFT	2	54	47-3/4	22	13	8	41	3 or 4
GS6-50-YBFT	2	55-3/4	49-1/2	24	13-1/4	8	42-1/2	3 or 4

Requires 120 VAC power supply.

Water connection is 3/4" on all models.

When ordering top-mounted T&P valve, add "G" to the model number (example: GS6 40 YBFT G).

All models are certified from sea level to 10,100 ft. elevation.

* GS6 50 YBFS available in natural gas only, all other models available in propane (LP) gas.

PROLINE® XE NON-CONDENSING ULTRA-LOW NOx FLUE DAMPER

PROLINE® XE
BEST



AUTOMATIC FLUE DAMPER

- Automatic flue damper increases efficiency to provide maximum household annual operating cost savings

GREEN CHOICE® GAS BURNER

- Enhanced Ultra-Low NOx burner complies with SCAQMD Rule 1121 and other air quality management districts with similar requirements for NOx emissions of less than 10ng/J

ELECTRONIC GAS CONTROL

SELF-CLEANING DIP TUBE

COREGARD™ ANODE ROD

BLUE DIAMOND® GLASS COATING

ENHANCED-FLOW BRASS DRAIN VALVE

REQUIRES 120V POWER 19.5' CORD INCLUDED

CODE COMPLIANCE

- Meets UBC, CEC and HUD (excluding mobile homes) National Codes
- Meets the thermal efficiency and standby loss requirements of the U.S. Department of Energy and current edition of ASHRAE/IES 90.1
- Complies with the Federal Energy Conservation Standards effective April 16, 2015, in accordance with the Energy Policy and Conservation Act, (EPCA), as amended

CSA AND DESIGN-CERTIFIED BY CSA INTERNATIONAL

- Certified at 300 psi test pressure and 150 psi working pressure
- Listed according to ANSI Z21.10.1 - CSA 4.1 standards governing storage tank-type water heaters

6-YEAR LIMITED TANK AND PARTS WARRANTY

- For complete information, consult written warranty or go to statewaterheaters.com

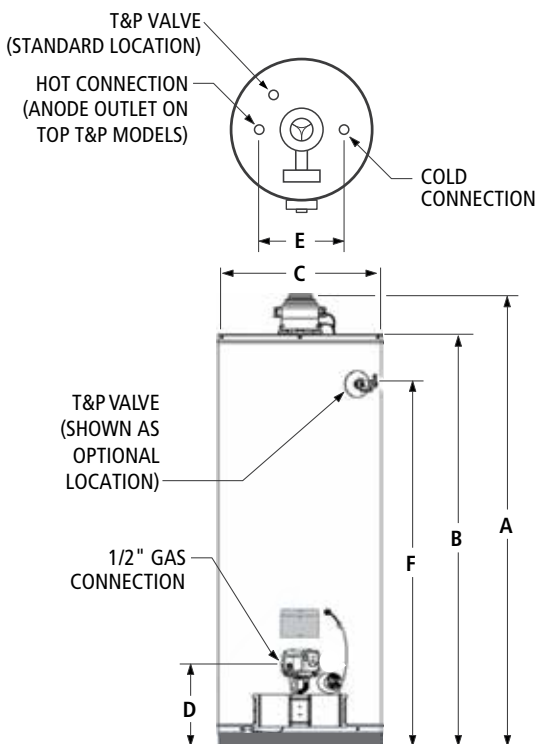

Maximum Hydrostatic Working Pressure: 150 PSI.

Model Number	Nominal Capacity	Rated Storage Volume	First Hour Rating (Gallons)	UEF	BTU Input Natural Gas	Recovery @ 90°F Rise (Gallon/Hour)	Approx. Shipping Weight
GS6-40-BFUT	40	38	68	0.65	40,000	42	152
GS6-50-BFUT	50	48	83	0.70	40,000	42	167

Model Number	Dimensions in Inches							Draft Hood Outlet
	Foam Thickness	A	B	C	D	E	F	
GS6-40-BFUT	2	64-1/4	58-1/4	20	13	8	51-3/4	3 or 4
GS6-50-BFUT	2	63-1/2	57-1/4	22	13	8	50-1/4	3 or 4

Requires 120VAC power supply located within 19ft of the heater.

Water connection is 3/4" on all models.

Standard top T&P, specify when ordering side T&P.

All models are certified from sea level to 7,800ft elevation.

PROLINE® XE ULTRA-LOW NO_x POWER VENT

PROLINE® XE
BEST



POWER VENTING MADE SIMPLE

- Thru-the-Wall or Thru-the-Roof power venting using either 2" or 3" PVC, ABS or CPVC vent pipe

INTELLI-VENT™ GAS CONTROL

- Advanced electronics for more precise control of water temperature and easy to understand system diagnostics

COMBINATION THERMOSTAT/ECO

- Utilizes an intermittent ignition gas valve (no standing pilot) with thermistor temperature sensor and built-in high temperature cut off

QUIET AND EFFICIENT BLOWER

- Factory-installed 6-foot power cord with 3-prong male connector provided. Electrical requirements; 110/120 VAC power source, less than 5 amp draw

SELF-CLEANING DIP TUBE

- Helps reduce lime and sediment buildup and maximizes hot water output. Made from long-lasting PEX cross-linked polymer.

COREGARD™ ANODE ROD

GREEN CHOICE® GAS BURNER

- Complies with SCAQMD Rule 1121 and other air quality management districts with similar requirements for NO_x emissions of less than 10 ng/J

ENHANCED-FLOW BRASS DRAIN VALVE

CODE COMPLIANCE

- Meets UBC, CEC and HUD National Codes
- Meets the thermal efficiency and standby loss requirements of the U. S. Department of Energy and current edition of ASHRAE/IES 90.1
- Complies with the Federal Energy Conservation Standards effective April 16, 2015, in accordance with the Energy Policy Conservation Act (EPCA), as amended

6-YEAR LIMITED TANK AND PARTS WARRANTY

- For complete information, consult written warranty or go to statewaterheaters.com

Top View

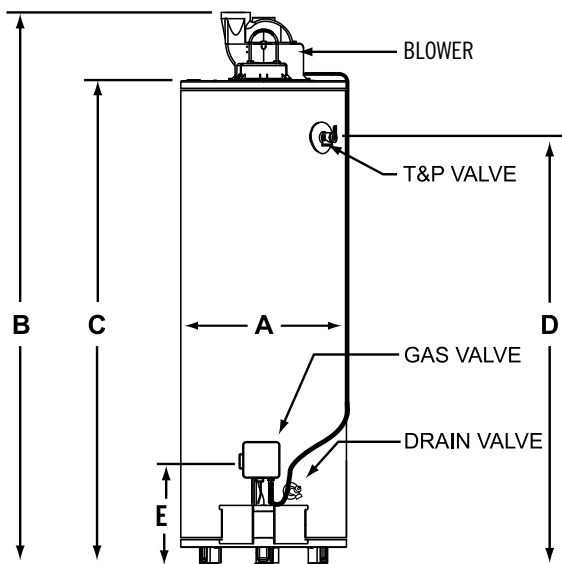
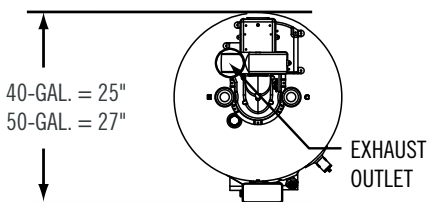

Model Number	Nominal Capacity	Rated Storage Volume	First Hour Rating (Gallons)	UEF	Recovery @ 90°F Rise Gallon Per Hour	BTU Input Gallon Per Hour	Approx. Shipping Weight (lbs)
GS6-40-UBVIT	40	38	76	0.70	42.6	42,000	170
GS6-50-UBVIT	50	48	71	0.65	42.6	42,000	207

Model Number	Dimensions in Inches					
	A	B	C	D	E	Draft Hood
GS6-40-UBVIT	20	66-7/8	58-5/8	51-1/2	12-1/4	2 or 3
GS6-50-UBVIT	22	66-8/8	57-7/16	51	12-1/4	2 or 3

No option available for top T&P valve.

PROLINE® MASTER ATMOSPHERIC VENT

**PROLINE® MASTER
BETTER**



INTELLIGENT CONTROL LOGIC

- The internal microprocessor provides enhanced operating parameters and tighter differentials for precise sensing and faster heating response to optimize performance
- Uses a thermopile to generate the power needed to operate the electronic gas control without requiring an external power source
- The electronic gas control incorporates an LED status indicator that monitors system operation and service diagnostics

*Not available on 60,000 BTU input models (GW8 50 RCT and GW8 55 RCT)

SELF-CLEANING DIP TUBE

COREGARD™ ANODE ROD

- ProLine® Master products have increased anode protection with either longer, or multiple anodes depending on model

PUSH-BUTTON PIEZO IGNITOR

ENHANCED-FLOW BRASS DRAIN VALVE

HEAT TRAP NIPPLES

BLUE DIAMOND® GLASS COATING

- Blue Diamond® Glass Coating blend is formulated in the same lab that creates the protection for our industry-leading commercial product line

CODE COMPLIANCE

- Meets UBC, CEC and HUD National Codes
- Meets the thermal efficiency and standby loss requirements of the U. S. Department of Energy and current edition of ASHRAE/IES 90.1
- Complies with the Federal Energy Conservation Standards effective April 16, 2015, in accordance with the Energy Policy and Conservation Act, (EPCA), as amended

DESIGN-CERTIFIED BY CSA INTERNATIONAL

- Certified at 300 psi test pressure and 150 psi working pressure
- Listed according to ANSI Z21.10.1-CSA 4.1 standards governing storage tank-type water heaters

8-YEAR LIMITED TANK AND PARTS WARRANTY

- For complete information, consult written warranty or go to statewaterheaters.com

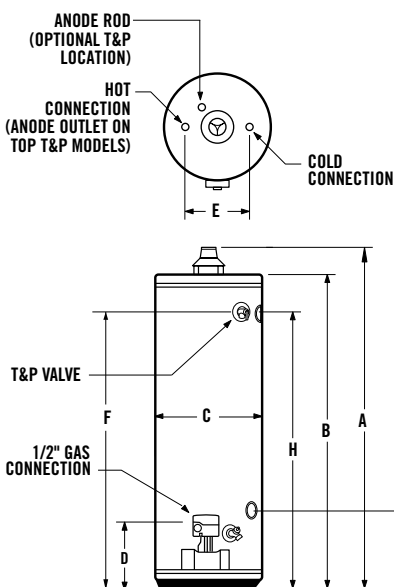

Maximum Hydrostatic Working Pressure: 150 PSI

Model Number	Nominal Capacity	Rated Storage Volume	UEF	First Hour Rating (Gallons)	BTU Input Natural Gas	BTU Input Propane Gas	Recovery 90°F Rise Gallon Per Hour
Tall Models							
GW8 40 BCT	40	38	0.64	80	40,000	36,000	42
GW8 50 BRT	50	48	0.62	81	40,000	37,000	41
GW8 50 BCT	50	48	0.62	84	40,000	37,000	43
GW8 50 RCT*	50	48	0.61	89	50,000	45,000	54
GW8 55 XCT*	55	55	0.62	83	60,000	54,000	65
Short Models							
GW8 40 BCS	40	38	0.58	67	40,000	36,000	41
GW8 50 BCS	50	50	0.62	81	40,000	40,000	43

Model Number	Dimensions in Inches									Approx. Shipping Weight (lbs)
	A	B	C	D	E	F	*G	*H	Draft Hood	
Tall Models										
GW8 40 BCT	61-3/4	58-1/4	20	12-1/4	8	52	N/A	N/A	3 or 4	138
GW8 50 BRT	60-3/4	57-1/4	21	12-1/4	8	50 1/2	N/A	N/A	3 or 4	148
GW8 50 BCT	60-3/4	57-1/4	22	12-1/4	8	50-1/2	N/A	N/A	3 or 4	165
GW8 50 RCT*	60-3/4	57-1/4	22	12-1/4	8	50-1/2	14-1/4	50-1/2	4	165
GW8 55 XCT*	59-3/4	55-1/4	24	13-1/2	8	48	14-1/4	48	4	185
Short Models										
GW8 40 BCS	51-1/2	48	22	12	8	41-1/4	N/A	N/A	3 or 4	135
GW8 50 BCS	53-1/4	49-3/4	24	12	8	41-3/8	N/A	N/A	3 or 4	177

Water connection is 3/4" on all models.

*Optional side-mounted recirculating taps, add "L" to the suffix in the model number (GW8 50 RCTL).

All models approved for installation from sea level to 10,100 ft. elevation.

PROLINE® MASTER ULTRA-LOW NOx

PROLINE® MASTER
BETTER



THE ELECTRONIC GAS CONTROL INCORPORATES AN LED STATUS INDICATOR THAT MONITORS SYSTEM OPERATION AND SERVICE DIAGNOSTICS

HIGH UNIFORM ENERGY FACTORS (UEFs)

- Eco-friendly non-CFC foam insulation, heat traps and specially designed combustion chamber combine to produce a high UEF for maximum savings on operating costs

GREEN CHOICE® GAS BURNER

- Enhanced Ultra-low NOx burner complies with SCAQMD Rule 1121 and other air quality management districts with similar requirements for NOx emissions of less than 10 ng/J

SELF-CLEANING DIP TUBE

COREGARD™ ANODE ROD

- ProLine® Master products have increased anode protection with either longer, or multiple anodes depending on model

PUSH-BUTTON PIEZO IGNITOR

HEAT TRAP NIPPLES

BLUE DIAMOND® GLASS COATING

- Blue Diamond® Glass Coating blend is formulated in the same lab that creates the protection for our industry-leading commercial product line

ENHANCED-FLOW BRASS DRAIN VALVE

CODE COMPLIANCE

- Meets UBC, CEC and HUD National Codes
- Meets the thermal efficiency and standby loss requirements of the U.S. Department of Energy and current edition of ASHRAE/IES 90.1
- Complies with the Federal Energy Conservation Standards effective April 16, 2015, in accordance with the Energy Policy Conservation Act (EPCA), as amended

DESIGN-CERTIFIED BY CSA INTERNATIONAL

- Certified at 300 psi test pressure and 150 psi working pressure
- Listed according to ANSI Z21.10.1-CSA 4.1 standards governing storage tank-type gas water heaters

8-YEAR LIMITED TANK AND PARTS WARRANTY

- For complete information, consult written warranty or go to statewaterheaters.com



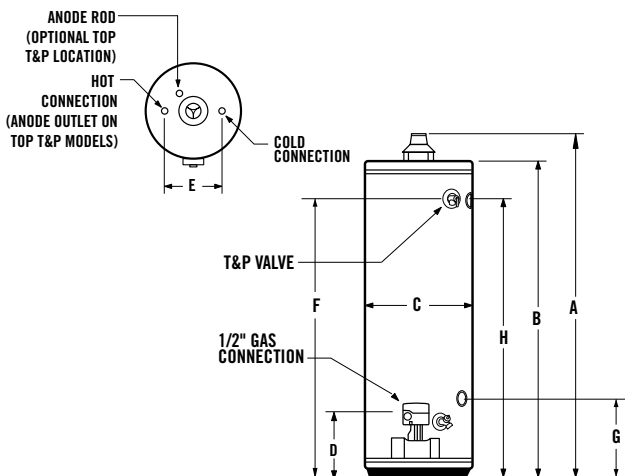

Maximum Hydrostatic Working Pressure: 150 PSI

Model Number	Nominal Capacity	Rated Storage Volume	First Hour Rating (Gallons)	UEF	BTU Input Natural Gas	Recovery @ 90°F Rise Gallon Per Hour	Approx. Shipping Weight (lbs)
Tall Models							
GW8-40-BRUT	40	38	83	0.64	40,000	41	125
GW8-40-BCUT	40	38	83	0.64	40,000	41	125
GW8-50-BRUT	50	48	84	0.61	40,000	42	148
GW8-50-BCUT	50	48	84	0.64	40,000	42	148
GW8-50-RCUTL*	50	48	91	0.60	50,000	51	177
Short Models							
GW8-40-BCUS	40	38	72	0.57	40,000	41	138

Model Number	Dimensions in Inches								Draft Hood
	A	B	C	D	E	F	G*	H*	
Tall Models									
GW8-40-BRUT	62	58-1/4	18	12	8	52	N/A	N/A	3 or 4
GW8-40-BCUT	62	58-1/4	20	12	8	52	N/A	N/A	3 or 4
GW8-50-BRUT	60-3/4	57-1/4	20	12	8	50-1/2	N/A	N/A	3 or 4
GW8-50-BCUT	60-3/4	57-1/4	22	12	8	50-1/2	N/A	N/A	3 or 4
GW8-50-RCUTL*	61	57-1/2	22	11 1/4	8	50-1/2	12-1/4	50-1/2	4
Short Models									
GW8-40-BCUS	51-1/2	47-3/4	22	12	8	41-1/4	N/A	N/A	3 or 4

All models may be ordered from the factory with top T&P valve as an option by adding "G" to the suffix of the model number (example GW8 40 BCUTG).

*Side loop connections are standard on model GW8 50 RCUTL.

*Most models approved for installation from sea level to 7,700 ft. elevation (except GW8 50 RCUTL, approved to 5,400 ft.).

PROLINE® HIGH CAPACITY ATMOSPHERIC VENT



HIGHEST RECOVERIES

- Capacity/input combinations up to 98 gallons/75,100 BTUs produce recoveries up to 81 gallons per hour

THE ELECTRONIC GAS CONTROL INCORPORATES AN LED STATUS INDICATOR THAT MONITORS SYSTEM OPERATION AND SERVICE DIAGNOSTICS

GREEN CHOICE® GAS BURNER

- Patented eco-friendly burner design reduces NOx emissions up to 33% and complies with Low-NOx emission requirements of 40 ng/J

SELF-CLEANING DIP TUBE

COREGARD™ ANODE ROD

PUSH-BUTTON PIEZO IGNITOR

BLUE DIAMOND® GLASS COATING

ENHANCED-FLOW BRASS DRAIN VALVE

CODE COMPLIANCE

- Meets UBC, CEC and ICC National Codes
- Meets the thermal efficiency and standby loss requirements of the U.S. Department of Energy and current edition of ASHRAE/IES 90.1

DESIGN-CERTIFIED BY CSA INTERNATIONAL

- Certified at 300 psi test pressure and 150 psi working pressure
- Listed according to ANSI Z21.10.1-CSA4.1 standards governing storage tank-type gas water heaters. CSA Certified and ASME Rated T&P Relief Valve.

MAXIMUM HYDROSTATIC WORKING PRESSURE 150 PSI

DESIGN-LISTED BY UNDERWRITERS LABORATORIES

- Certified at 300 psi test pressure and 150 psi working pressure
- Listed according to ANSI Z21.10.3 CSA 4.3 standards governing storage tank-type water heaters

6-YEAR LIMITED TANK AND PARTS WARRANTY

- For complete information, consult written warranty or go to statewaterheaters.com

TOP VIEW

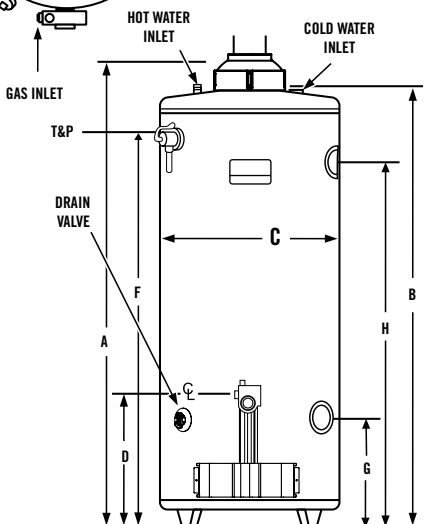
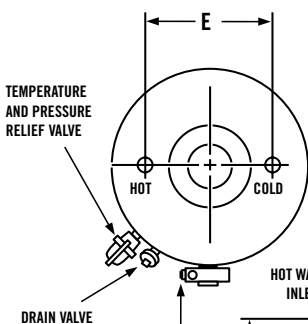

FRONT VIEW

Model Number	Nominal Capacity	Rated Storage Volume	UEF	First Hour Rating (Gallons)	BTU Input Natural Gas	Recovery @ 90°F Rise Gallon Per Hour	Approx. Shipping Weight (lbs)
GS6-75-XRRS	74	71	0.60	125	75,100	81	270
GS6-100-XRRT	98	95	0.58	170	75,100	81	340

Model Number	Dimensions in Inches								
	A	B	C	D	E	F	G	H	Draft Hood
GS6-75-XRRS	61	58-1/2	26-1/2	15-3/16	16	50-1/4	15-1/2	50-1/4	4
GS6-100-XRRT	68-1/2	66-1/2	27-3/4	15-3/16	16	57-3/8	N/A	N/A	4

Water connections are 1" male NPT on GS6-75-XRRS and 1-1/4" on GS6-100-XRRT.

All models are certified from sea level to 7,700 ft. elevation.

For 10-year tank and 10-year parts limited warranty, change "6" to "X" in the model number (example: GSX 75 XRRS).

For optional side-mounted recirculating taps, add "L" to suffix (example: GS6-75-XRRS L).

When ordering propane (LP) gas change "X" to "C" in the model number (example: GS6-75-CRRS).

PROLINE® DIRECT VENT



DIRECT VENT DESIGN

- One-pipe, dual-channel closed system draws all make-up air from outside the home, eliminating problems caused by insufficient indoor ventilation and is FVIR compliant
- Horizontal air intake and venting on all models up to 80 inches from outside wall with no electrical power needed

INTELLIGENT CONTROL LOGIC

GREEN CHOICE® GAS BURNER

- Patented eco-friendly gas burner design reduces NOx emissions by up to 33% and complies with Low-NOx emission requirements of less than 40 ng/J

SELF-CLEANING DIP TUBE

COREGARD™ ANODE ROD

PUSH BUTTON PIEZO IGNITOR

HEAT TRAP NIPPLES

CODE COMPLIANCE

- Meets UBC, CEC and HUD National Codes
- Meets the thermal efficiency and standby loss requirements of the U.S. Department of Energy and current edition of ASHRAE/IES 90.1.
- Complies with the Federal Energy Conservation Standards effective April 16, 2015, in accordance with the Energy Policy and Conservation Act (EPCA), as amended

DESIGN-CERTIFIED BY CSA INTERNATIONAL

- Certified at 300 psi test pressure and 150 psi working pressure. Listed according to ANZI Z21. 10.1-CSA 4.1 standards governing storage tank-type gas water heaters

6-YEAR LIMITED TANK AND PARTS WARRANTY

- For complete information, consult written warranty or go to statewaterheaters.com



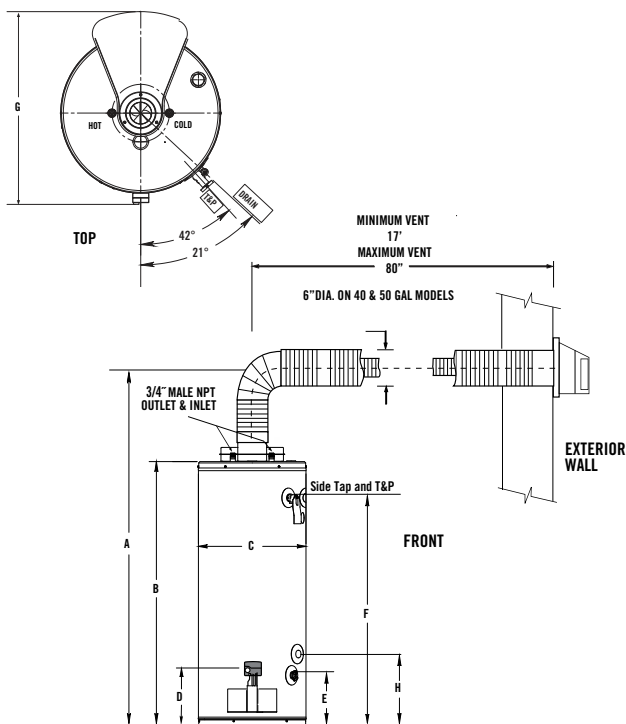

Model Number	Nominal Capacity	Rated Storage Volume	First Hour Rating (Gallons)	UEF	Recovery 90°F Rise Gallon Per Hour	Input BTU per Hour	Vent Outlet	Approx. Shipping Weight (lbs)
GS6-40-YBDS	40	39	64	0.60	41	38,000	Co-Axial	178
GS6-50-YBDS	50	48	77	0.66	43	40,000	Co-Axial	200
GS6-50-YRDS	50	48	83	0.65	51	47,000	Co-Axial	215

Model Number	Dimensions in Inches							
	A	B	C	D	E	F	*G	H
GS6 40 YBDS	64	49-3/4	22	13-1/4	15-1/4	42-1/2	29	15-1/4
GS6 50 YBDS	73	59	22	13-1/4	15-1/4	51-3/4	29	15-1/4
GS6 50 YRDS	74	60	22	13-1/4	15-1/4	52-3/4	29	15-1/4

Dual-channel system has 3" vent pipe inside 6" air intake pipe, for the 40 and 50-gallon models.

All models have 2" foam cavity.

Water connection is 3/4" male on all models.

40 and 50 gallon models are 8" on center.

* Allow 29-1/2" front to back dimensions for air intake at rear of heater.

All models are available in propane (LP) gas (series 301).

All models are certified from sea level to 7,700 ft. elevation.

All models are available with side loop fittings. Add "L" to the model number (example: GS6-40-YBDS-L).

PROLINE® ATMOSPHERIC VENT



INTELLIGENT CONTROL LOGIC

- The internal microprocessor provides enhanced operating parameters and tighter differentials for precise sensing and faster heating response to optimize performance
- Uses a thermopile to generate the power needed to operate the electronic gas control without requiring an external power source
- The electronic gas control incorporates an LED status indicator that monitors system operation and service diagnostics

*Not available on 60,000 BTU input models GS6-50-XCT and GS6-55-XCT

SELF CLEANING DIP TUBE

COREGARD™ ANODE ROD

PUSH-BUTTON PIEZO IGNITOR

ENHANCED-FLOW BRASS DRAIN VALVE

HEAT TRAP NIPPLES

BLUE DIAMOND® GLASS COATING

CODE COMPLIANCE

- Meets UBC, CEC and HUD National Codes
- Meets the thermal efficiency and standby loss requirements of the U. S. Department of Energy and current edition of ASHRAE/IES 90.1
- Complies with the Federal Energy Conservation Standards effective April 16, 2015, in accordance with the Energy Policy and Conservation Act, (EPCA), as amended

DESIGN-CERTIFIED BY CSA INTERNATIONAL

- Certified at 300 psi test pressure and 150 psi working pressure
- Listed according to ANSI Z21.10.1-CSA 4.1 standards governing storage tank-type water heaters

6-YEAR LIMITED TANK AND PARTS WARRANTY

- For complete information, consult written warranty or go to statewaterheaters.com

Model Number	Nominal Capacity	Rated Storage Volume	First Hour Rating (Gallons)	UEF	BTU Input Natural Gas	BTU Input Propane Gas	Recovery @ 90°F Rise Gallon Per Hour	Approx. Shipping Weight (lbs)
Tall Models								
†GS6-30-ORBTR	30	29	62	0.60	32,000	29,000	32	123
GS6-30-OCTR	30	29	62	0.60	32,000	29,000	31	132
‡GS6-40-OCT	40	38	65	0.59	35,500	N/A	38	138
†GS6-40-BRBT	40	38	78	0.65	40,000	36,000	42	130
GS6-40-BCT*	40	38	80	0.64	40,000	36,000	42	138
GS6-50-BRT*	50	48	81	0.62	40,000	37,000	41	148
GS6-50-BCT*	50	48	84	0.62	40,000	37,000	43	165
GS6-50-RCT*	50	48	89	0.61	50,000	45,000	54	165
†GS6-50-XCT*	50	49	99	0.61	60,000	54,000	65	190
GS6-55-XCT*	55	55	83	0.62	60,000	54,000	65	185
Short Models								
†GS6-30-ORBSR	30	29	65	0.60	32,000	29,000	32	114
GS6-30-OCSR	30	29	55	0.60	32,000	29,000	32	108
†GS6-40-BRBS	40	38	68	0.57	40,000	36,000	41	134
GS6-40-BCS	40	38	67	0.58	40,000	36,000	41	135
GS6-50-BCS	50	50	81	0.62	40,000	40,000	43	177

Water connection is 3/4" on all models.

*Optional side-mounted recirculating taps, add "L" to the suffix in the model number (GS6-50-RCTL).

† Models ship with supplied insulation blanket.

For 10-year tank and 10-year parts limited warranty, change "6" to "X" in the model number (example: GSX-30-OCT).

All models approved for installation from sea level to 10,100 ft. elevation.

‡ LP models not available on GS6-40-OCT.

Dimensions and line drawings on the following pages.

PROLINE® ATMOSPHERIC VENT

(CONTINUED)

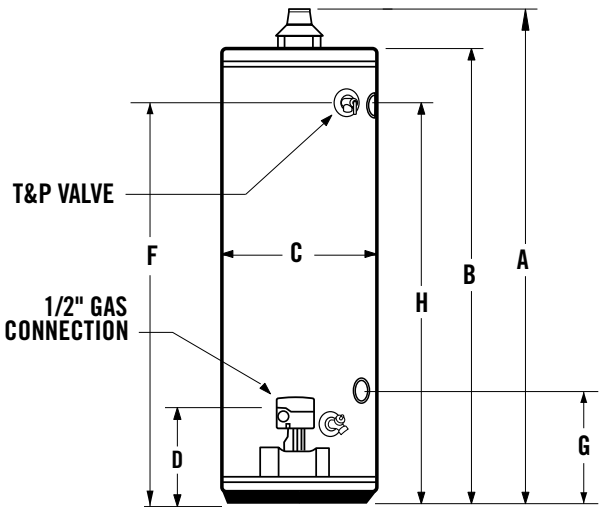
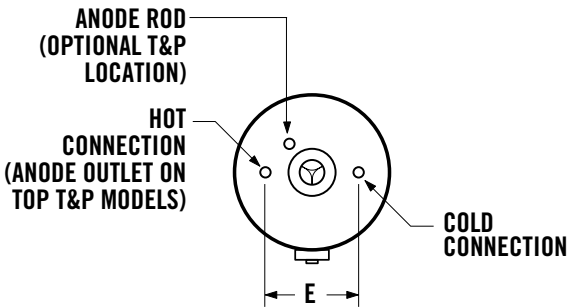

Maximum Hydrostatic Working Pressure: 150 PSI

Model Number	Dimensions in Inches								
	A	B	C	D	E	F	*G	*H	Draft Hood
TALL MODELS									
†GS6-30-ORBTR	60-1/2	57	16	14	8	51	N/A	N/A	3 or 4
GS6-30-OCTR	60-1/2	57	18	14	8	51	N/A	N/A	3 or 4
‡GS6-40-OCT	61-3/4	58-1/4	20	12-1/4	8	52	N/A	N/A	3 or 4
†GS6-40-BRBT	61-3/4	58-1/4	18	12-1/4	8	52	N/A	N/A	3 or 4
GS6-40-BCT*	61-3/4	58-1/4	20	12-1/4	8	52	14-1/4	51-3/4	3 or 4
GS6-50-BRT*	60-3/4	57-1/4	21	12-1/4	8	50 1/2	14-1/4	50-1/2	3 or 4
GS6-50-BCT*	60-3/4	57-1/4	22	12-1/4	8	50-1/2	14-1/4	50-1/2	3 or 4
GS6-50-RCT*	60-3/4	57-1/4	22	12-1/4	8	50-1/2	14-1/4	50-1/2	4
†GS6-50-XCT*	65-1/2	61	22	13-1/2	8	54-1/4	14-1/4	54-1/4	4
GS6-55-XCT*	59-3/4	55-1/4	24	13-1/2	8	48	14-1/4	48	4
SHORT MODELS									
†GS6-30-ORBSR	50-1/4	46-3/4	18	14	8	40	N/A	N/A	3 or 4
GS6-30-OCSR	50-1/4	46-3/4	20	14	8	40	N/A	N/A	3 or 4
†GS6-40-BRBS	51-1/2	48	20	12	8	41-1/4	N/A	N/A	3 or 4
GS6-40-BCS	51-1/2	48	22	12	8	41-1/4	N/A	N/A	3 or 4
GS6-50-BCS	53-1/4	49-3/4	24	12	8	41-3/8	N/A	N/A	3 or 4

Water connection is 3/4" on all models.

*Optional side-mounted recirculating taps, add "L" to the suffix in the model number (GS6-50-RCTL).

† Models ship with supplied insulation blanket.

For 10-year tank and 10-year parts limited warranty, change "6" to "X" in the model number (example: GSX-40-BCT).

All models approved for installation from sea level to 10,100 ft. elevation.

‡ LP models not available on GS6-40-OCT.

PROLINE® MOBILE HOME ATMOSPHERIC VENT



COMPLIES WITH HUD STANDARDS FOR MANUFACTURED HOUSING INSTALLATION

GAS CONTROL CONVERTIBLE FOR NATURAL AND PROPANE GAS

- For flexibility to meet the varying needs of manufactured housing installations

SIDE-MOUNTED 3/4" COLD WATER INLET

- For ease of installation when cold water supply originates below the structure
- Top mounted 3/4" hot water outlet

GREEN CHOICE® GAS BURNER

- Patented eco-friendly burner design reduces NOx emissions by up to 33% and complies with Low-NOx emission requirements of less than 40 ng/J

COREGARD™ ANODE ROD

BLUE DIAMOND® GLASS COATING

ENHANCED-FLOW BRASS DRAIN VALVE

CODE COMPLIANCE

- Meets UBC, CEC and HUD National Codes
- Meets the thermal efficiency and standby loss requirements of the U.S. Department of Energy and current edition of ASHRAE/IES 90.1
- Complies with the Federal Energy Conservation Standards effective April 16, 2015, in accordance with the Energy Policy and Conservation Act (EPCA), as amended

DESIGN-CERTIFIED BY CSA INTERNATIONAL

- Certified at 300 psi test pressure and 150 psi working pressure
- Listed according to ANSI Z21.10.1-CSA4.1 standards governing storage tank-type gas water heaters

CSA CERTIFIED AND ASME RATED T&P RELIEF VALVE

6-YEAR LIMITED TANK AND PARTS WARRANTY

- For complete information, consult written warranty or go to statewaterheaters.com

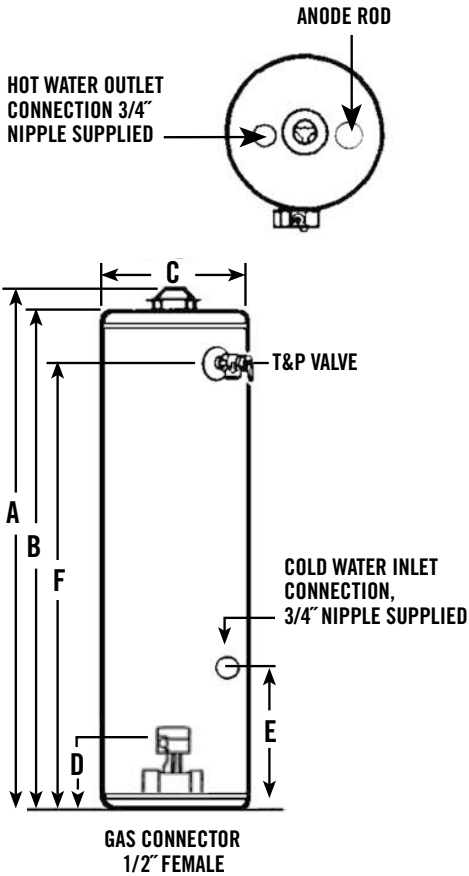

Model Number	Nominal Capacity	Rated Storage Volume	First Hour Rating (Gallons)	UEF	Recovery @ 90°F Rise Gallon Per Hour	Btu Input Per Hour Natural Gas	Btu Input Per Hour Propane	Approx. Shipping Weight (lbs)
GS6-30-MHG	30	29	63	0.61	36	35,500	32,000	129
GS6-40-MHG	40	38	59	0.58	36	35,500	32,000	153

Model Number	Dimensions in Inches						Draft Hood Outlet
	A	B	C	D	E	F	
GS6-30-MHG	61-1/2	58	18	13	14-1/4	52	3 or 4
GS6-40-MHG	61-3/4	58-1/4	20	13	14-1/4	51-3/4	3 or 4

All models ship from the factory for use with natural gas, a complete propane (LP) burner is supplied for converting to propane gas.

All models are certified from sea level to 10,100 ft. elevation.

No option available for top T&P.

PROLINE® MOBILE HOME DIRECT VENT



COMPLIES WITH HUD STANDARDS FOR MANUFACTURED HOUSING INSTALLATION

GAS CONTROL CONVERTIBLE FOR NATURAL AND PROPANE GAS

- For flexibility to meet the varying needs of manufactured housing installations

DIRECT VENT MODELS PACKAGE WITH BOTTOM INTAKE AIR VENT

- To draw all combustion make-up air from outside the structure

OPTIONAL DUCTED AIR INLET KIT FOR DIRECT VENT MODELS

- For use when water heater is installed over a basement
- Provision for horizontal air inlet ducting

SIDE-MOUNTED 3/4" COLD WATER INLET

GREEN CHOICE® GAS BURNER

- Patented eco-friendly burner design reduces NOx emissions by up to 33% and complies with Low-NOx emission requirements of less than 40 ng/J

SELF-CLEANING DIP TUBE

COREGARD™ ANODE ROD

ENHANCED-FLOW BRASS DRAIN VALVE

BLUE DIAMOND® GLASS COATING

CODE COMPLIANCE

- Meets UBC, CEC and HUD National Codes
- Meets the thermal efficiency and standby loss requirements of the U.S. Department of Energy and current edition of ASHRAE/IES 90.1
- Complies with the Federal Energy Conservation Standards effective April 16, 2015, in accordance with the Energy Policy and Conservation Act (EPCA), as amended

DESIGN-CERTIFIED BY CSA INTERNATIONAL

- Certified at 300 psi test pressure and 150 psi working pressure
- Listed according to ANSI Z21.10.1-CSA 4.1 standards governing storage tank-type gas water heaters

CSA CERTIFIED AND ASME RATED T&P RELIEF VALVE

6-YEAR LIMITED TANK AND PARTS WARRANTY

- For complete information, consult written warranty or go to statewaterheaters.com



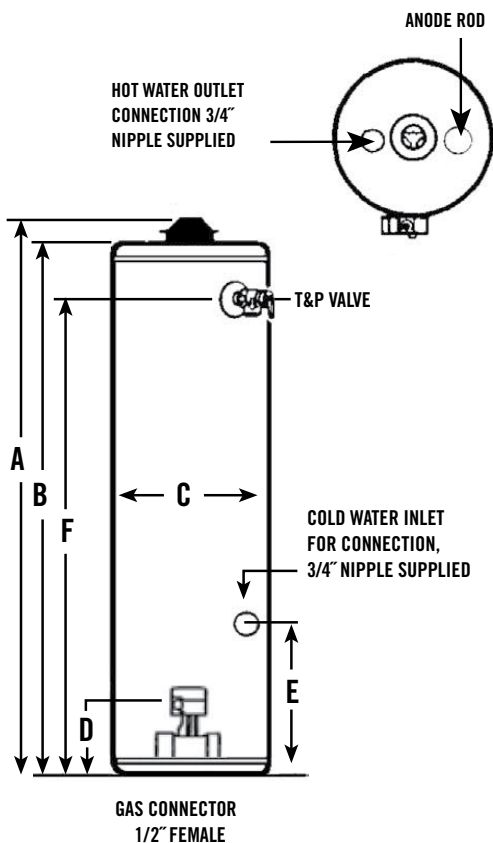

Model Number	Nominal Capacity	Rated Storage Volume	First Hour Rating (Gallons)	UEF	Btu Input Per Hour Natural Gas	Btu Input Per Hour Propane	Recovery @ 90°F Rise Gallon Per Hour	Approx. Shipping Weight (lbs)
GS6-30-MDV	30	29	60	0.61	30,000	29,000	31	129
GS6-40-MDV	40	38	57	0.59	32,000	29,000	33	153
GS6-50-MDV	50	47	67	0.56	40,000	37,000	39	168

Model Number	Dimensions in Inches						
	A	B	C	D	E	F	Vent Outlet
GS6-30-MDV	61	58	18	13	14-1/4	52-1/2	3
GS6-40-MDV	61-3/4	58-3/4	20	13	14-1/4	52-1/4	3
GS6-50-MDV	60	57	22	13	14-1/4	50	3

Certified from sea level to 5,400 ft. elevation.

No option available for top T&P.

All models ship from the factory for use with natural gas, a complete propane burner is supplied for converting to propane gas.

Water connection is 3/4" on all models..

PROLINE® ULTRA-LOW NO_x



THE ELECTRONIC GAS CONTROL INCORPORATES AN LED STATUS INDICATOR THAT MONITORS SYSTEM OPERATION AND SERVICE DIAGNOSTICS

HIGH UNIFORM ENERGY FACTORS (UEFS)

- Eco-friendly non-CFC foam insulation, heat traps and specially designed combustion chamber combine to produce a high UEF for maximum savings on operating costs

GREEN CHOICE® GAS BURNER

- Enhanced Ultra-low NO_x burner complies with SCAQMD Rule 1121 and other air quality management districts with similar requirements for NO_x emissions of less than 10 ng/J

SELF-CLEANING DIP TUBE

COREGARD™ ANODE ROD

PUSH-BUTTON PIEZO IGNITOR

HEAT TRAP NIPPLES

BLUE DIAMOND® GLASS COATING

ENHANCED-FLOW BRASS DRAIN VALVE

CODE COMPLIANCE

- Meets UBC, CEC and HUD National Codes
- Meets the thermal efficiency and standby loss requirements of the U.S. Department of Energy and current edition of ASHRAE/IES 90.1
- Complies with the Federal Energy Conservation Standards effective April 16, 2015, in accordance with the Energy Policy Conservation Act (EPCA), as amended

DESIGN-CERTIFIED BY CSA INTERNATIONAL

- Certified at 300 psi test pressure and 150 psi working pressure
- Listed according to ANSI Z21.10.1-CSA 4.1 standards governing storage tank-type gas water heaters

6-YEAR LIMITED TANK AND PARTS WARRANTY

- For complete information, consult written warranty or go to statewaterheaters.com



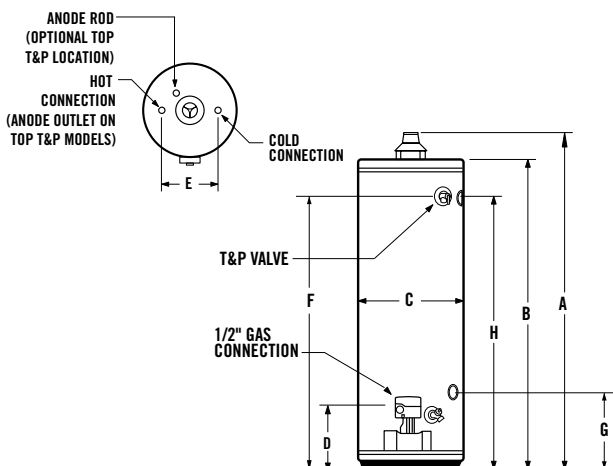

Maximum Hydrostatic Working Pressure: 150 PSI

Model Number	Nominal Capacity	Rated Storage Volume	First Hour Rating (Gallons)	UEF	BTU Input Natural Gas	Recovery @ 90°F Rise Gallon Per Hour	Approx. Shipping Weight (lbs)
Tall Models							
GS6-30-ORUT	30	29	62	0.59	33,000	34	126
GS6-40-BRUT	40	38	83	0.64	40,000	41	125
GS6-40-BCUT	40	38	83	0.64	40,000	41	125
GS6-50-BRUT	50	48	84	0.61	40,000	42	148
GS6-50-BCUT	50	48	84	0.64	40,000	42	148
GS6-50-RCUT*	50	48	91	0.60	50,000	51	177
Short Models							
GS6-40-BCUS	40	38	72	0.57	40,000	41	138

Model Number	Dimensions in Inches								
	A	B	C	D	E	F	G*	H*	Draft Hood
TALL MODELS									
GS6-30-ORUT	61-3/4	58	16	12	8	51-3/4	N/A	N/A	3 or 4
GS6-40-BRUT	62	58-1/4	18	12	8	52	N/A	N/A	3 or 4
GS6-40-BCUT	62	58-1/4	20	12	8	52	N/A	N/A	3 or 4
GS6-50-BRUT	60-3/4	57-1/4	20	12	8	50-1/2	N/A	N/A	3 or 4
GS6-50-BCUT	60-3/4	57-1/4	22	12	8	50-1/2	N/A	N/A	3 or 4
GS6-50-RCUT*	61	57-1/2	22	12-1/4	8	50-1/2	12-1/4	50-1/2	4
SHORT MODELS									
GS6-40-BCUS	51-1/2	47-3/4	22	12	8	41-1/4	N/A	N/A	3 or 4

All models may be ordered from the factory with top T&P valve as an option by adding "G" to the suffix of the model number (example GS6-30-ORUTG). *Side loop connections are standard on model GS6-50-RCUT.

Most models approved for installation from sea level to 7,700 ft. elevation (except GS6-50-RCUT, approved to 5,400 ft.). For 10-year tank and 10-year parts limited warranty, change "6" to "X" in the model number (example: GSX-30-ORUT).

PROLINE® ULTRA-LOW NO_x DIRECT VENT



FLAMMABLE VAPOR RESISTANT/DIRECT VENT SEALED COMBUSTION SYSTEM

DURABLE, ULTRA-LOW NO_x BURNER CONSTRUCTION

NON-CFC FOAM INSULATION

- The tank is surrounded by a thick coat of non-CFC polyurethane foam to trap heat inside the tank, saving energy

¾" TOP WATER CONNECTIONS AND SIDE SPACE HEATING CONNECTIONS

½" GAS CONNECTION

COREGARD™ ANODE ROD

BLUE DIAMOND® GLASS COATING

ENHANCED-FLOW BRASS DRAIN VALVE

GREEN CHOICE® GAS BURNER

- Complies with SCAQMD Rule 1121 and other air quality management districts with similar requirements for NO_x emissions of less than 10 ng/J

CODE COMPLIANCE

- Meets UBC, CEC and HUD National Codes
- Meets the thermal efficiency and standby loss requirements of the U.S. Department of Energy and current edition of ASHRAE/IES 90.1
- Complies with the Federal Energy Conservation Standards effective April 16, 2015, in accordance with the Energy Policy and Conservation Act (EPCA), as amended

DESIGN-LISTED BY CSA INTERNATIONAL

- Certified at 300 psi test pressure and 150 psi working pressure
- Listed according to ANSI Z21.10.1-CSA 4.1 standards governing storage tank-type gas water heaters

CSA CERTIFIED AND ASME RATED T&P RELIEF VALVE

6-YEAR LIMITED TANK AND PARTS WARRANTY

- For complete information, consult written warranty or go to statewaterheaters.com



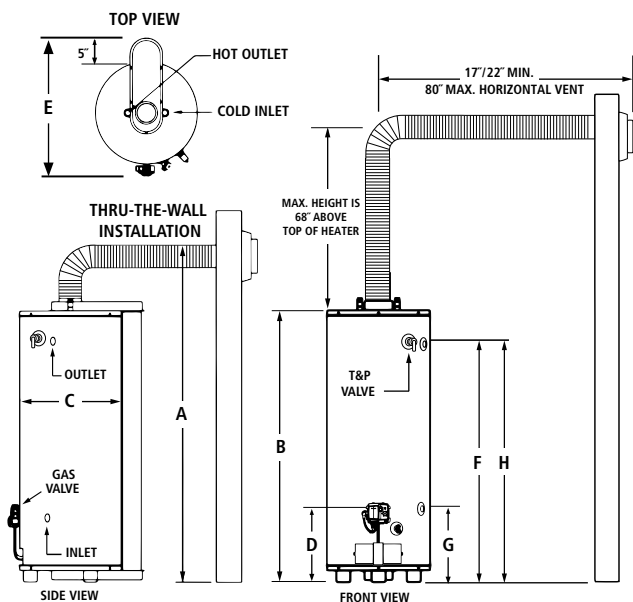

Model Number	Nominal Capacity	Rated Storage Volume	First Hour Rating (Gallons)	UEF	Recovery 90°F Rise Gallon Per Hour	BTU Input Per Hour	Approx. Shipping Weight (lbs)
GS6-40-UBDS-L	40	28	52	0.60	39	36,000	179
GS6-50-UBDT-L	50	48	76	0.65	41	38,000	193

Model Number	Dimensions in Inches								
	Concentric Vent Connection	A	B	C	D	E	F	G	H
GS6-40-UBDS-L	3 or 5	65-1/4	50-1/2	22	13-1/2	30	43-7/8	15	45
GS6-50-UBDT-L	3 or 5	58-1/2	73-1/2	22	13-1/2	30	52-1/4	15	53

No option available for top T&P valve.

All models have 3/4" top water connections and comes standard with side loop sittings.

All models are certified from sea level to 7,700 ft. elevation.

PROLINE® ULTRA-LOW NO_x HIGH CAPACITY



FULLY AUTOMATIC CONTROLS WITH SAFETY SHUTOFF

HEAVY GAUGE STEEL JACKET

BLUE DIAMOND® GLASS COATING

FOAM INSULATION

ULTRA-LOW NO_x EMISSIONS

- Complies with SCAQMD Rule 1146.2 and other Air Quality Management Districts with similar requirements of 14 ng/J or 20 ppm

EASY-TO-INSTALL

- Completely factory-assembled. Only gas, water and vent connections need to be made. All connections are located in front and top of heaters for ease-of-installation and service.

COREGARD™ ANODE ROD

- Our anode rods have a stainless steel core that extends the life of the anode rod, allowing superior tank protection far longer than standard anode rods

MAXIMUM WORKING PRESSURE

- 150 psi.

MAXIMUM GAS INLET PRESSURE

- 14" W.C.

CODE COMPLIANCE

- Meets UBC, CEC and ICC National Codes
- The Ultra-Low NO_x atmospheric vent residential gas water heater meets the thermal efficiency and standby loss requirements of the U.S. Department of Energy and Current Edition ASHRAE/IES 90.1

6-YEAR LIMITED TANK AND PARTS WARRANTY

- For complete information, consult written warranty or go to statewaterheaters.com

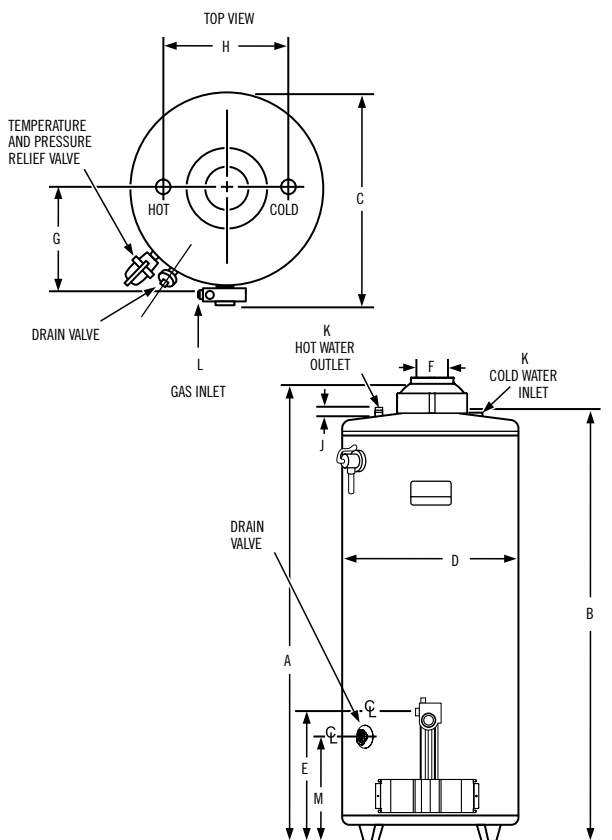

Model Number	Nominal Capacity	Rated Storage Volume	First Hour Rating (Gallons)	UEF	Recovery at 90°F Rise Gallon Per Hour	BTU Input Per Hour
†GS6-75-URRS	74	71	102	0.64	81	75,100
GS6-100-URRT	98	95	120	0.58	82	75,100

Model Number	Dimensions in Inches					
	A	B	C	D	E	F
†GS6-75-URRS	62-1/16	58	29-1/2	25-1/4	15-7/8	4
GS6-100-URRT	70-1/2	66-1/2	30-15/16	27-3/4	15-3/16	4

Model Number	Dimensions in Inches						Approx. Shipping Weight
	G	H	J	K	L	M	
†GS6-75-URRS	15-1/4	16	2	1	1/2	12-1/2	285 lbs
GS6-100-URRT	15-3/4	16	1-1/4	1-1/4	1/2	11-15/16	350 lbs

*Recovery rating based on 81% thermal efficiency

**Recovery rating based on 80% thermal efficiency

†The GS6-75-URRS comes standard with side loop fittings for use with hydronic heating applications

PREMIER® AL SMART HYBRID ELECTRIC HEAT PUMP

PROLINE® XE
BEST



10-YEAR
10
WARRANTY



LEAK PROTECTION TECHNOLOGY

- Smart anode adapts to local water conditions to protect and extend the life of the water heater
- User is notified when the anode is consumed and needs to be replaced
- Smart sensor alerts user in the event a leak does occur for added peace of mind
- Compatible with accessory automatic water shutoff valve for enhanced protection

EXCEPTIONAL ENERGY EFFICIENCY

- Improved efficiency up to 4.02 Uniform Energy Factor (UEF) can reduce the cost of water heating by up to 78%*
- ENERGY STAR® certified for many state and local utility rebates

iCOMM™ SMART CONNECTIVITY

- Monitor and control your water heater through the free State Water Heaters app
- Connect through a local Wi-Fi network or directly to the water heater through Bluetooth
- If applicable download the Time of Use schedule of your local electric utility to prioritize heating when the rates are most affordable
- Receive alerts and notifications

FLEXIBLE DESIGN

- Top and front water connections for easy installation
- Zero clearance required on sides and back to fit in tighter spaces
- Integrated ducting adapters for installations in confined spaces

QUIET OPERATION

- Whisper-quiet operation at 45 dBA

ELECTRONIC CONTROLS

- User-friendly electronic interface allows easy control of temperature, operating mode and diagnostics
- Select from Heat Pump, Hybrid or Electric modes to match hot water demand. Vacation mode can reduce energy use while you are away.
- Long-lasting 4500W backup elements can supplement the heat pump depending on operating mode, environmental conditions and hot water demand

CODE COMPLIANCE

- NEEA Tier 4
- California Title 24 JA13 Qualified
- CTA-2045 (AC)
- OpenADR 2.0b VEN
- Meets IBC and HUD Codes

10-YEAR LIMITED TANK AND PARTS WARRANTY

- For complete information, consult written warranty or go to statewaterheaters.com

*Comparing 66-gallon Premier AL heat pump against pre-2015 similarly-sized standard electric using DOE EF to UEF conversion rates. Savings may vary.

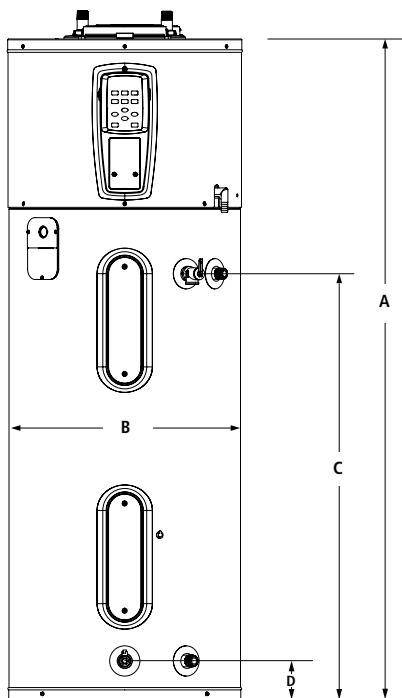

Model Number	Nominal Capacity	Rated Storage Volume	UEF	First Hour Rating (Gallons)	Approx. Shipping Weight (lbs)	Warranty Term
HPSX-50-DHPT	50	46	3.80	65	196	10
HPSX-66-DHPT	66	67	4.02	82	284	10
HPSX-80-DHPT	80	82	3.88	95	302	10

Model Number	Dimensions in Inches			
	A	B	C	D
HPSX-50-DHPT	63	22	40-1/2	3-3/4
HPSX-66-DHPT	61-1/2	26-1/2	38-1/4	4
HPSX-80-DHPT	69	26-1/2	46-1/2	4

Requires 208/240 VAC 50/60Hz single phase power and 30 amp breaker.
Top T&P option not available on this model.

PROLINE® XE HYBRID ELECTRIC HEAT PUMP WATER HEATER

PROLINE® XE
BEST



10-YEAR
10
WARRANTY



INCREASED ENERGY EFFICIENCY

- Reduce water heating costs up to 73% compared to a standard electric water heater
- Up to a 3.45 Uniform Energy Factor (UEF) Rating conserves energy and meets ENERGY STAR® qualifications

DUAL VOLTAGE CAPABLE

- 208/240 VAC 60Hz capable for use in almost any residential application

CHOICE OF OPERATING MODES

- Select from Efficiency, Hybrid, or Electric modes to match heating requirements to environmental conditions and hot water demand. Hybrid mode automatically adjusts between compressor and element, depending upon heat requirements.
- Vacation mode reduces operating costs and provides freeze protection during extended absence

BACKUP ELECTRIC ELEMENTS

- Long-lasting 4500W backup heating elements help heat water according to environmental conditions, demand and the chosen operating mode

DRY FIRE PROTECTION

- Control system ensures the tank is full of water during start up to prevent dry firing the heating elements

ELECTRONIC USER INTERFACE

- User-friendly electronic interface allows easy control of temperature setting, operating mode, and communicates diagnostics
- Advanced diagnostics convey error messages for service purposes. The last four error messages are saved in the control system memory.

OTHER FEATURES

- Ideal for basements or garage installations; the compressor transfers heat to the water while dehumidifying and cooling the ambient air
- Washable air filter is easily removed for routine cleaning
- Accessory Inlet/Outlet Duct Kit (Part number 100234320)

10-YEAR LIMITED TANK AND PARTS WARRANTY

- For complete information, consult written warranty or go to statewaterheaters.com

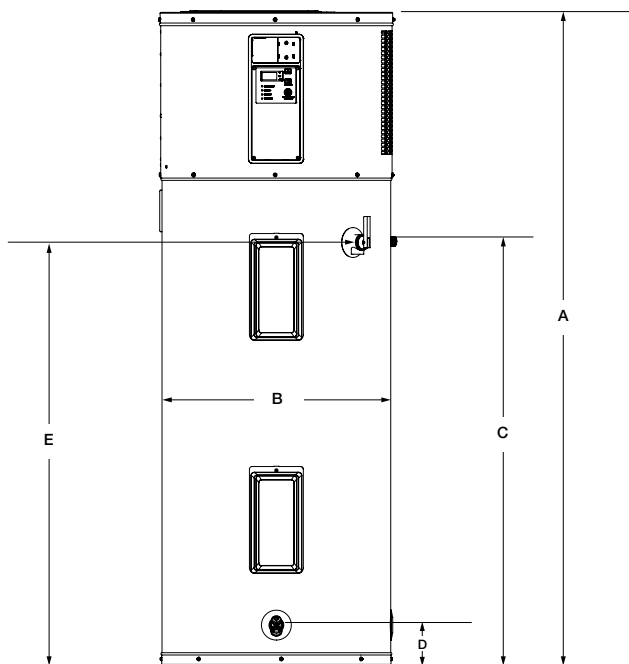

Model Number	Nominal Capacity	Rated Storage Volume	UEF	First Hour Rating (Gallons)	Approx. Shipping Weight (lbs)
HPX-50-DHPTNE	50	46	3.45	66	196
HPX-66-DHPTNE	66	67	3.45	79	289
HPX-80-DHPTNE	80	82	3.45	86	307

Model Number	Dimensions in Inches				
	A	B	C	D	E
HPX-50-DHPTNE	63	22	40-5/8	3-3/4	40-1/2
HPX-66-DHPTNE	61	27	38	4	38
HPX-80-DHPTNE	69	27	46	4	46

Top T&P option not available.

PROLINE® XE HYBRID ELECTRIC HEAT PUMP WATER HEATER

PROLINE® XE
BEST



6-YEAR
6
WARRANTY



INCREASED ENERGY EFFICIENCY

- Reduce water heating costs up to 73% compared to a standard electric water heater
- Up to a 3.45 Uniform Energy Factor (UEF) Rating conserves energy and meets ENERGY STAR® qualifications

DUAL VOLTAGE CAPABLE

- 208/240 VAC 60Hz capable for use in almost any residential application

CHOICE OF OPERATING MODES

- Select from Efficiency, Hybrid, or Electric modes to match heating requirements to environmental conditions and hot water demand. Hybrid mode automatically adjusts between compressor and element, depending upon heat requirements.
- Vacation mode reduces operating costs and provides freeze protection during extended absence

BACKUP ELECTRIC ELEMENTS

- Long-lasting 4500W backup heating elements help heat water according to environmental conditions, demand and the chosen operating mode

DRY FIRE PROTECTION

- Control system ensures the tank is full of water during start up to prevent dry firing the heating elements

ELECTRONIC USER INTERFACE

- User-friendly electronic interface allows easy control of temperature setting, operating mode, and communicates diagnostics
- Advanced diagnostics convey error messages for service purposes. The last four error messages are saved in the control system memory.

OTHER FEATURES

- Ideal for basements or garage installations; the compressor transfers heat to the water while dehumidifying and cooling the ambient air
- Washable air filter is easily removed for routine cleaning
- Accessory Inlet/Outlet Duct Kit (Part number 100234320)

6-YEAR LIMITED TANK AND PARTS WARRANTY

- For complete information, consult written warranty or go to statewaterheaters.com

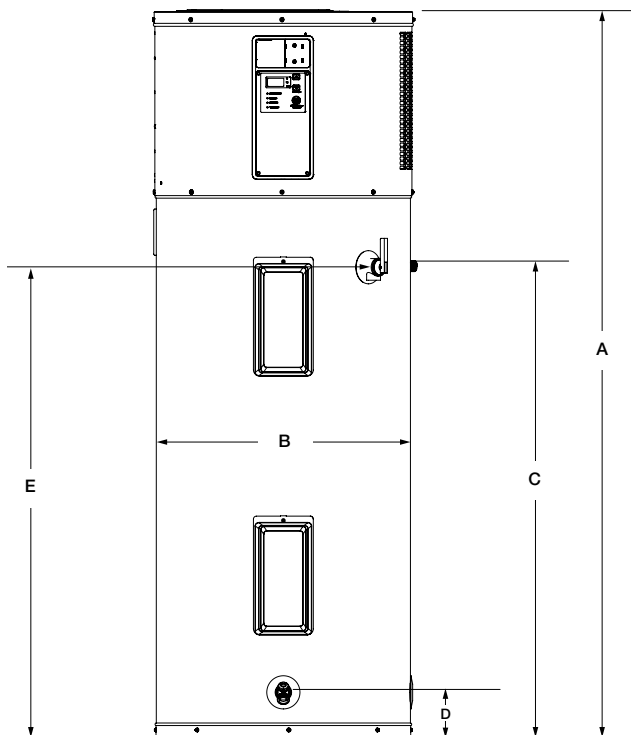

Model Number	Nominal Capacity	Rated Storage Volume	UEF	First Hour Rating (Gallons)	Approx. Shipping Weight (lbs)
HP6-50-DHPT	50	46	3.35	66	196
HP6-66-DHPT	66	67	3.42	79	289
HP6-80-DHPT	80	82	3.45	84	307

Model Number	Dimensions in Inches					Warranty Term
	A	B	C	D	E	
HP6-50-DHPT	63	22	40-5/8	3-3/4	40-1/2	6
HP6-66-DHPT	61	27	38	4	38	6
HP6-80-DHPT	69	27	46	4	46	6

Requires 30 amp breaker.
Top T&P option not available.

PROLINE® MASTER SMART ELECTRIC

PROLINE® MASTER
BETTER



ELECTRONIC CONTROLS WITH WIFI CONNECTIVITY

- Standard and vacation operating modes
- Seven-segment display
- Diagnostic feedback
- Element “Dry-Fire” protection

REMOTE CONTROL THROUGH THE STATE WATER HEATERS APP

- Change water temperature and operating mode remotely
- Schedule hot water demand for optimized performance

LEAK DETECTION SENSOR

- Sounds an audible alarm when water is detected

AUTOMATIC SHUT-OFF VALVE

- Closes valve on incoming cold water inlet when leak is detected

ENHANCED HEATING ELEMENTS

- Dual 5500 watt elements for the fastest recovery and reliable operation
- Stainless steel elements last longer than standard copper elements

HIGH ENERGY FACTORS

- Eco-friendly non-CFC foam insulation, heat traps and other features combine to yield a high Uniform Energy Factor (UEF) that maximizes savings on operating costs

COREGARD™ ANODE ROD

- Our anode rods have a stainless steel core that extends the life of the anode rod allowing superior tank protection far longer than standard anode rods

CODE COMPLIANCE

- Meets UBC, CEC and HUD National Codes
- Meets the thermal efficiency and standby loss requirements of the U.S. Department of Energy and current edition of ASHRAE/IES 90.1
- Complies with the Federal Energy Conservation
- Standards effective April 16, 2015, in accordance with the Energy Policy and Conservation Act (EPCA), as amended

8-YEAR LIMITED TANK AND PARTS WARRANTY

- 4 year warranty extension available
- For complete information, consult written warranty or go to statewaterheaters.com

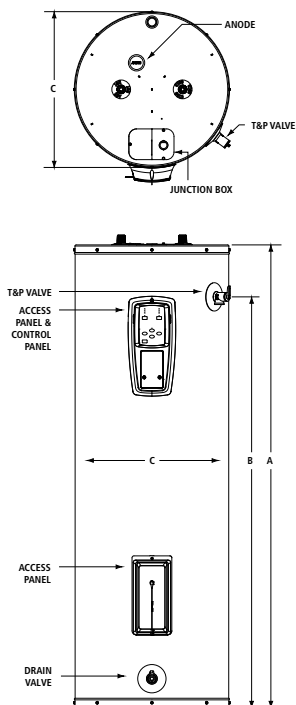

Model Number	Nominal Capacity	Rated Storage Volume	First Hour Rating (Gallons)	UEF	Recovery @ 90°F Rise Gallon Per Hour	Approx. Shipping Weight (lbs)
Tall Models						
EE8-40-DFRT	40	36	63	0.93	25	106
EE8-50-DFRT	50	45	74	0.92	25	109
EE8-55-DFRT	55	55	75	0.94	25	145
Short Models						
EE8-40-DFRS	40	37	64	0.92	25	95
EE8-50-DFRS	50	46	67	0.92	25	117

Model Number	Element Wattage 240V		Dimensions in Inches		
	Standard	Maximum	A	B	C
Tall Models					
EE8-40-DFRT	5500	5500	60-1/4	53-1/4	20
EE8-50-DFRT	5500	5500	59	51-1/4	20-1/2
EE8-55-DFRT	5500	5500	56-1/2	48-1/2	24
Short Models					
EE8-40-DFRS	5500	5500	49-3/4	40-3/4	20-1/2
EE8-50-DFRS	5500	5500	49-3/4	40-1/4	23

3/4" water connections on 8" center.

Only available for 240V or 208V applications. Equipped as dual element only, no single element configurations available. Minimum wattage available is 4,500 watt elements.

Dimensions and specifications subject to change without notice in accordance with our policy of continuous product improvement.

PROLINE® MASTER ELECTRIC GRID-CAPABLE

PROLINE® MASTER
BETTER



Low Lead Content



ELECTRONIC CONTROLS WITH WIFI CONNECTIVITY

- Standard and vacation operating modes
- Seven-segment display
- Diagnostic feedback
- Element “Dry-Fire” protection

REMOTE CONTROL THROUGH THE STATE WATER HEATERS APP

- Change water temperature and operating mode remotely
- Schedule hot water demand for optimized performance

LEAK DETECTION SENSOR

- Sounds an audible alarm when water is detected

AUTOMATIC SHUT-OFF VALVE

- Closes valve on incoming cold water inlet when leak is detected

ENHANCED HEATING ELEMENTS

- Dual 5500 watt elements for the fastest recovery and reliable operation
- Stainless steel elements last longer than standard copper elements

HIGH ENERGY FACTORS

- Eco-friendly non-CFC foam insulation, heat traps and other features combine to yield a high Uniform Energy Factor (UEF) that maximizes savings on operating costs

COREGARD™ ANODE ROD

- Our anode rods have a stainless steel core that extends the life of the anode rod allowing superior tank protection far longer than standard anode rods

CODE COMPLIANCE

- Meets UBC, CEC and HUD National Codes
- Meets the thermal efficiency and standby loss requirements of the U.S. Department of Energy and current edition of ASHRAE/IES 90.1
- Complies with the Federal Energy Conservation
- Standards effective April 16, 2015, in accordance with the Energy Policy and Conservation Act (EPCA), as amended
- Meets state of WA and OR requirements

8-YEAR LIMITED TANK AND PARTS WARRANTY

- 4 year warranty extension available
- For complete information, consult written warranty or go to statewaterheaters.com

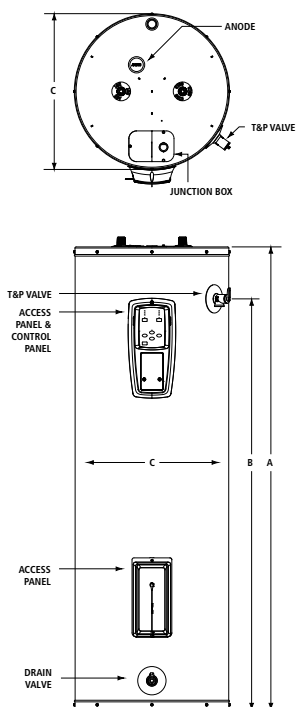

Model Number	Nominal Capacity	Rated Storage Volume	First Hour Rating (Gallons)	UEF	Recovery @ 90°F Rise Gallon Per Hour	Approx. Shipping Weight (lbs)
Tall Models						
EEA8-40-DFRT	40	36	63	0.93	25	106
EEA8-50-DFRT	50	45	74	0.92	25	109
EEA8-55-DFRT	55	55	75	0.94	25	145
Short Models						
EEA8-40-DFRS	40	37	64	0.92	25	95
EEA8-50-DFRS	50	46	67	0.92	25	117

Model Number	Element Wattage 240V		Dimensions in Inches		
	Standard	Maximum	A	B	C
Tall Models					
EEA8-40-DFRT	5500	5500	60-1/4	53-1/4	20
EEA8-50-DFRT	5500	5500	59	51-1/4	20-1/2
EEA8-55-DFRT	5500	5500	56-1/2	48-1/2	24
Short Models					
EEA8-40-DFRS	5500	5500	49-3/4	40-3/4	20-1/2
EEA8-50-DFRS	5500	5500	49-3/4	40-1/4	23

3/4" water connections on 8" center.

Only available for 240V or 208V applications. Equipped as dual element only, no single element configurations available. Minimum wattage available is 4,500 watt elements.

Dimensions and specifications subject to change without notice in accordance with our policy of continuous product improvement.

PROLINE® MASTER

PROLINE® MASTER
BETTER



COMMERCIAL-GRADE HEATING ELEMENTS

- Dual 4500 watt elements for faster recovery and reliable operation
- Long-lasting dual stainless steel elements last longer than standard copper elements

BLUE DIAMOND® GLASS COATING

- Blue Diamond® Glass Coating blend is formulated in the same lab that creates the protection for our industry-leading commercial product line

HIGH UNIFORM ENERGY FACTOR (UEF)

SELF-CLEANING DIP TUBE

COREGARD™ ANODE ROD

- ProLine® Master products have increased anode protection with either longer, or multiple anodes depending on model

CODE COMPLIANCE

- Meets UBC, CEC and HUD National Codes
- Meets the thermal efficiency and standby loss requirements of the U.S. Department of Energy and current edition of ASHRAE/IES 90.1
- Complies with the Federal Energy Conservation Standards effective April 16, 2015, in accordance with the Energy Policy and Conservation Act (EPCA), as amended

APPROVED FOR MANUFACTURED HOUSING

- All residential electric water heaters are compliant with HUD standards for mobile homes/manufactured housing

DESIGN-LISTED BY UNDERWRITERS LABORATORIES

- Certified at 300 psi test pressure and 150 psi working pressure
- Listed according to UL174 standards governing storage tank-type water heaters

8-YEAR LIMITED TANK AND PARTS WARRANTY

- For complete information, consult written warranty or go to statewaterheaters.com

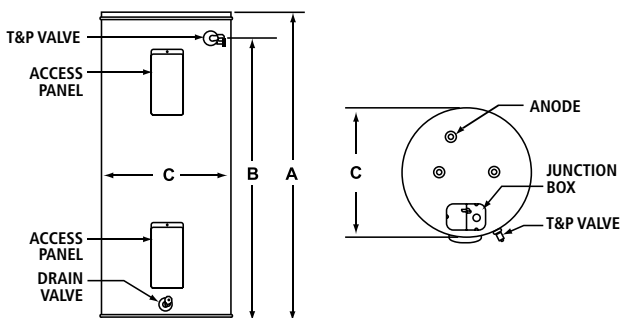

Model Number	Nominal Capacity	Rated Storage Volume	First Hour Rating (Gallons)	UEF	Recovery @ 90°F Rise Gallon Per Hour
Tall Models					
EN8-40-DORT	40	36	53	0.92	21
EN8-50-DORT	50	46	62	0.92	21
EN8-55-DORT	55	55	72	0.93	21
Short Models					
EN8-40-DORS	40	37	55	0.92	21
EN8-40-DORSW	40	37	41	0.88	18
EN8-50-DORS	50	46	57	0.92	21

Model Number	Element Wattage 240V			Dimensions in Inches			Approx. Shipping Weight (lbs)
	Standard	Minimum	Maximum	A	B	C	
Tall Models							
EN8-40-DORT	4500	3500	6000	61-1/4	53-1/4	18	118
EN8-50-DORT	4500	@ 3000	6000	59	51-1/4	20-1/2	125
EN8-55-DORT	4500	2500	6000	56-1/2	48-1/2	24	145
Short Models							
EN8-40-DORS	4500	@ 4500	6000	49-3/4	40-3/4	20-1/2	109
EN8-40-DORSW	-	1000	4000	49-3/4	40-3/4	20-1/2	109
EN8-50-DORS	4500	2500	6000	49-3/4	40-3/8	23	161

Male 3/4" water connections on 8" center.

Models requiring a lower wattage than what is listed in the minimum wattage column and showing the @ symbol, will change to a "W" suffix model number.

"W" suffix models are available down to 1kW. (example: EN8-40-DORS using 4,000 watt elements or less will become "EN8-40-DORSW").

Dimensions and specifications subject to change without notice in accordance with our policy of continuous product improvement.

PROLINE® GRID-CAPABLE ELECTRIC WATER HEATERS



ELECTRONIC CONTROLS

- Standard and vacation operating modes
- Six-segment display
- Diagnostic feedback
- Element “Dry-Fire” protection

UTILITY GRID-CAPABLE

- Equipped with Demand Response (CTA-2045*EcoPort^{CM}) communication port
- Allows for participation in Utility Demand Response programs (Module needed from local utility)
- Meets state of Washington and Oregon requirements

HIGH ENERGY FACTORS

- Eco-friendly non-CFC foam insulation, heat traps and other features combine to yield a high Energy Factor that maximizes savings on operating costs

COREGARD™ ANODE ROD

- Our anode rods have a stainless steel core that extends the life of the anode rod allowing superior tank protection far longer than standard anode rods

CODE COMPLIANCE

- Meets UBC, CEC and HUD National Codes
- Meets the thermal efficiency and standby loss requirements of the U.S. Department of Energy and current edition of ASHRAE/IES 90.1
- Complies with the Federal Energy Conservation Standards effective April 16, 2015, in accordance with the Energy Policy and Conservation Act (EPCA), as amended

6-YEAR LIMITED TANK AND PARTS WARRANTY

- 6 and 10 year warranty models
- For complete information, consult written warranty or go to statewaterheaters.com

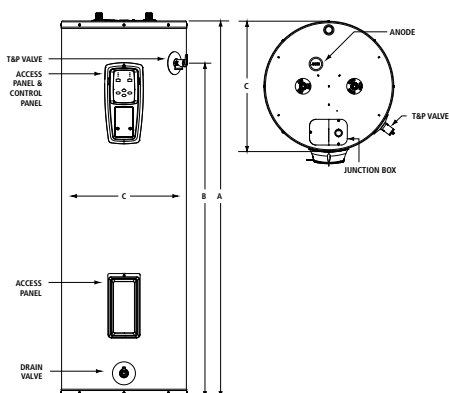

Model Number	Nominal Capacity	Rated Storage Volume	First Hour Rating (Gallons)	UEF	Element Wattage 240V	
					Standard	Maximum
Tall Models						
EE6-40-DURT†	40	36	55	0.93	4500	5500
EE6-50-DURT†	50	46	62	0.92	4500	5500
EE6-55-DURT†	55	55	75	0.94	4500	5500
Short Models						
EE6-40-DURS†	40	37	53	0.92	4500	5500
EE6-50-DURS†	50	46	67	0.92	4500	5500
Lowboy Top Connect Models						
EE6-40-DULS†	38	35	52	0.92	4500	5500
EE6-50-DULS†	51	48	54	0.92	4500	5500
EE6-50-DULBS†	48	44	55	0.92	4500	5500

Model Number	Recovery @ 90°F Rise Gallon Per Hour	Dimensions in Inches			Approx. Shipping Weight (lbs)
		A	B	C	
Tall Models					
EE6-40-DURT†	21	60-1/4	53-1/4	20	106
EE6-50-DURT†	21	59	51-1/4	20-1/2	109
EE6-55-DURT†	21	56-1/2	48-1/2	24	145
Short Models					
EE6-40-DURS†	21	49-3/4	40-3/4	20-1/2	95
EE6-50-DURS†	21	49-1/4	40-1/4	23	117
Lowboy Top Connect Models					
EE6-40-DULS†	21	31-1/2	24	26	118
EE6-50-DULS†	21	36	26-1/4	26-1/2	154
EE6-50-DULBS†	21	34	24-1/4	26-1/2	154

3/4" water connections on 8" center.

Only available for 240V applications.

Equipped as dual element only, no single element configurations available.

Top T&P is not available on the 10 year Lowboy models.

Minimum wattage available is 4,500 watt elements.

Dimensions and specifications subject to change without notice in accordance with our policy of continuous product improvement.

†For 10-year tank and parts warranty, change first "E" to "P" in the model number.

PROLINE®



ENHANCED HEATING ELEMENTS

- Dual 4500 watt elements for faster recovery and reliable operation
- Incoloy stainless steel lower element lasts longer than a standard copper element

HIGH UNIFORM ENERGY FACTOR (UEF)

SELF-CLEANING DIP TUBE

COREGARD™ ANODE ROD

- Increased anode protection with either longer or multiple anodes depending on model

LONG-LASTING STAINLESS STEEL UPPER AND LOWER ELEMENTS

CODE COMPLIANCE

- Meets UBC, CEC and HUD National Codes
- Meets the thermal efficiency and standby loss requirements of the U.S. Department of Energy and current edition of ASHRAE/IES 90.1
- Complies with the Federal Energy Conservation Standards effective April 16, 2015, in accordance with the Energy Policy and Conservation Act (EPCA), as amended

APPROVED FOR MANUFACTURED HOUSING

- All residential electric water heaters are compliant with HUD standards for mobile homes/manufactured housing

DESIGN-LISTED BY UNDERWRITERS LABORATORIES

- Certified at 300 psi test pressure and 150 psi working pressure
- Listed according to UL174 standards governing storage tank-type water heaters

6-YEAR LIMITED TANK AND PARTS WARRANTY

- For complete information, consult written warranty or go to statewaterheaters.com

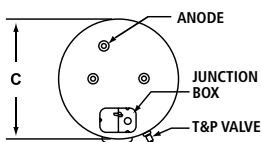
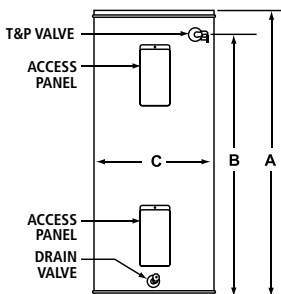

Model Number	Nominal Capacity	Rated Storage Volume	First Hour Rating (Gallons)	UEF	Recovery @ 90°F Rise Gallon Per Hour	Approx. Shipping Weight (lbs)
Tall Models						
†EN6-30-DORT	30	27	48	0.89	21	95
†EN6-40-DORT	40	36	53	0.92	21	118
†EN6-50-DORT	50	46	62	0.92	21	125
†EN6-55-DORT	55	55	72	0.93	21	145
Short Models						
EN6-30-DOBS*	30	27	50	0.90	21	95
†EN6-30-DORS	30	27	47	0.89	21	94
†EN6-40-DORS	40	37	55	0.92	21	109
†EN6-40-DORSW	40	37	41	0.88	18	109
†EN6-50-DORS	50	46	57	0.92	21	161
Lowboy Top Connect Models						
†EN6-30-DOLBS*	28	26	43	0.89	21	90
†EN6-30-DOLS	28	26	44	0.90	21	115
†EN6-36-DOLS	36	33	51	0.92	21	118
†EN6-40-DOLS	38	35	50	0.89	21	118
†EN6-40-DOLBS*	38	35	51	0.92	21	118
†EN6-40-DOLBSW*	38	35	38	0.90	18	118
†EN6-50-DOLBS*	48	44	60	0.93	21	172
†EN6-50-DOLBSW*	48	44	40	0.91	16	172
†EN6-50-DOLS	51	48	51	0.92	21	172

Model Number	Element Wattage 240V			Dimensions in Inches		
	Standard	Minimum	Maximum	A	B	C
Tall Models						
†EN6-30-DORT	4500	1000	6000	46-1/2	39-1/2	19
†EN6-40-DORT	4500	3500	6000	61-1/4	53-1/4	18
†EN6-50-DORT	4500	@ 3000	6000	59	51-1/4	20-1/2
†EN6-55-DORT	4500	2500	6000	56-1/2	48-1/2	24
Short Models						
EN6-30-DOBS*	4500	1000	6000	39	30-1/2	20
†EN6-30-DORS	4500	1000	6000	39-3/4	30-1/2	22
†EN6-40-DORS	4500	@ 4500	6000	49-3/4	40-3/4	20-1/2
†EN6-40-DORSW	-	1000	4000	49-3/4	40-3/4	20-1/2
†EN6-50-DORS	4500	2500	6000	49-1/4	40-3/8	23
Lowboy Top Connect Models						
†EN6-30-DOLBS*	4500	1000	6000	30	21-3/4	20
†EN6-30-DOLS	4500	1000	6000	31 1/4	21-3/4	24
†EN6-36-DOLS	4500	@ 4500	6000	32	24	24
†EN6-40-DOLS	4500	1000	6000	33 1/2	24	26
†EN6-40-DOLBS*	4500	@ 4500	6000	32	24	23
†EN6-40-DOLBSW*	-	1000	4000	32	24	23
†EN6-50-DOLBS*	4500	@ 4000	6000	34	25	26-1/2
†EN6-50-DOLBSW*	-	1000	3500	34	25	26-1/2
†EN6-50-DOLS	4500	4000	6000	36	25	26-1/2

Male 3/4" water connections on 8" center.

*Models ship with supplied insulation blanket.

†For 10-year tank and 10-year parts limited warranty, change "N6" to "SX" in select models and "R" to "N" in tall and short model number (example: ESX-40-DONT).

"W" suffix models are available down to 1kW. (example: EN6-40-DORS using 4,000 watt elements or less will become "EN6-40-DORSW").

Top T&P is not available on the 10 year lowboy models.

Dimensions and specifications subject to change without notice in accordance with our policy of continuous product improvement.

MOBILE HOME



APPROVED FOR MANUFACTURED HOUSING

- All residential electric water heaters are compliant with HUD Standards for mobile homes/manufactured housing

SIDE WATER CONNECTIONS

- For ease of installation in mobile home applications

COREGARD™ ANODE ROD

- Our anode rods have a stainless steel core that extends the life of the anode rod allowing superior tank protection far longer than standard anode rods

LONG-LASTING HEATING ELEMENTS

- Screw-in, direct immersion, 3500W/240V or 3000W/120V heating elements for maximum efficiency

BLUE DIAMOND® GLASS COATING

ENHANCED-FLOW BRASS DRAIN VALVE

- Our residential water heaters have a solid brass, tamper resistant, enhanced-flow, ball type, drain valve
- Uses a standard female hose fitting that allows for fast and easy draining during maintenance

CSA CERTIFIED AND ASME RATED T&P RELIEF VALVE

CODE COMPLIANCE

- Meets UBC, CEC and HUD National Codes
- Meets the thermal efficiency and standby loss requirements of the U. S. Department of Energy and current edition of ASHRAE/IES 90.1
- Complies with the Federal Energy Conservation Standards effective April 16, 2015, in accordance with the Energy Policy and Conservation Act (EPCA), as amended

DESIGN-LISTED BY UNDERWRITERS LABORATORIES

- Certified at 300 psi test pressure and 150 psi working pressure
- Listed according to UL174 standards governing storage tank-type water heaters

6-YEAR LIMITED TANK AND PARTS WARRANTY

- For complete information, consult written warranty or go to statewaterheaters.com

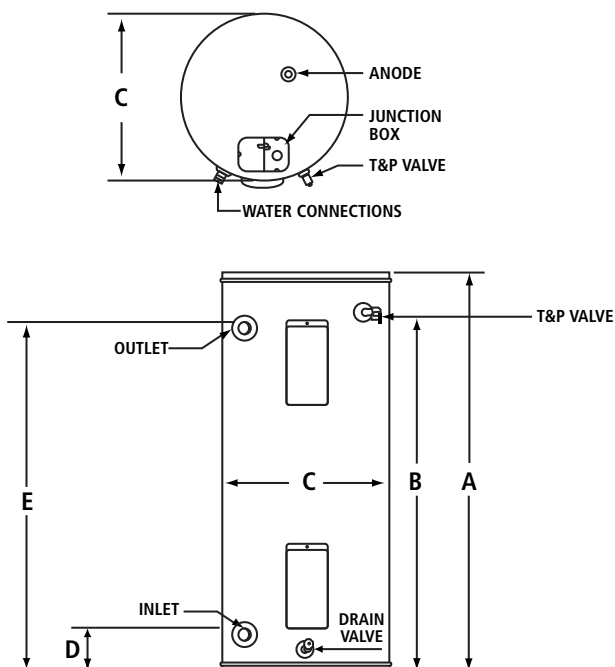

Model Number	Nominal Capacity	Rated Storage Volume	First Hour Rating (Gallons)	UEF	Recovery @ 90°F Rise Gallon Per Hour	Voltage
EN6-30-DMHT	30	27	50	0.90	14	120
	30	27	50	0.90	16	240
EN6-40-DMHSW	40	36	40	0.91	14	120
	40	36	40	0.91	16	240
EN6-30-DMHLS	28	26	47	0.90	14	120
	28	26	47	0.90	16	240

Model Number	Voltage	Wattage		Dimensions in Inches		Approx. Shipping Weight (lbs)
		Upper Element	Lower Element	Height to Top of Heater	Diameter	
EN6-30-DMHT	120	3000	3000	46-3/4	19	98
	240	3500	3500	46-3/4	19	98
EN6-40-DMHSW	120	3000	3000	50	22	109
	240	3500	3500	50	22	109
EN6-30-DMHLS	120	3000	3000	30	22	96
	240	3500	3500	30	22	96

*Models ship with supplied insulation blanket.

MHE6 models may have limited element options due to element size or other restrictions.

3/4" water connections

Available with side T&P only.

PROLINE® SPECIALTY



Table Top



Point-Of-Use



Compact



Lowboy



APPROVED FOR MANUFACTURED HOUSING

All residential electric water heaters are compliant with HUD standards for mobile homes/ manufactured housing

TABLE TOP

- Features a convenient flat porcelain surface at 36" height, providing extra "counter space" wherever installed. All plumbing and electrical connections are made through the back of the water heater. This heater is equipped with a PEX cross-linked polymer dip tube.

POINT-OF-USE

- Designed for low-demand, such as office lavatories or buildings with remote restrooms

COMPACT

- Side-mounted plumbing and electrical connections (optional top-mounted water connections for field conversion). Designed for installation under a counter, in a crawl space or in other tight spaces.

ENHANCED-FLOW BRASS DRAIN VALVE

CODE COMPLIANCE

- Meets UBC, CEC and HUD National Codes
- Meets the thermal efficiency and standby loss requirements of the U.S. Department of Energy and current edition of ASHRAE/IES 90.1
- Complies with the Federal Energy Conservation Standards effective April 16, 2015, in accordance with the Energy Policy and Conservation Act (EPCA), as amended

DESIGN-LISTED BY UNDERWRITERS LABORATORIES

- Certified at 300 psi test pressure and 150 psi working pressure
- Listed according to UL174 standards governing storage tank-type water heaters

6-YEAR LIMITED TANK AND PARTS WARRANTY

- For complete information, consult written warranty or go to statewaterheaters.com

Compact Models



ES6 6 SOMS ES6 10 SOMS ES6 20 SOMS ES6 20 SOMS

I	INLET	D	DRAIN	J*	PLUGGED INLET	A	ANODE
O	OUTLET	T	T&P	O*	PLUGGED OUTLET		

Lowboy

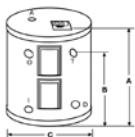

ES6 30 DOMS, ES6 30 SOMSK,
ES6 40 DOMS, ES6 40 SOMNS K,

Table Top Model

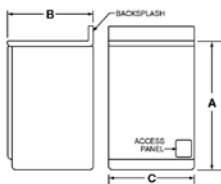

Point-Of-Use

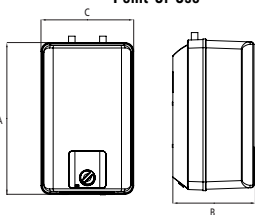

Model Number	Nominal Capacity	Rated Storage Volume	First Hour Rating (Gallons)	UEF	Recovery @ 90°F Rise Gallons Per Hour
Compact Models					
ES6-6-SOMS-K	6	6	N/A	N/A	8
ES6-10-SOMS-K	10	9	N/A	N/A	8
ES6-20-SOMS-K	19	17	N/A	N/A	11
ES6-20-SOMT-K	19.9	18	N/A	N/A	11
Lowboy Side-Connect Model					
EN6-30-DOMBS*	28	26	47	0.90	21
EN6-30-DOMS	28	26	43	0.91	21
EN6-40-DOMBS*	38	35	57	0.94	21
EN6-40-DOMBSW*	38	35	38	0.91	18
EN6-40-DOMS	38	35	54	0.93	21
EN6-40-DOMSW	38	35	38	0.91	18
Table Top Model					
EN6-38-2OTT	38	35	55	0.90	21
Point-Of-Use-Models					
ES6-2-SMT	2.5	2.6	N/A	N/A	7
ES6-4-SMT	4	3.8	N/A	N/A	7
ES6-6-SMT	6	5.9	N/A	N/A	7

Model Number	Element Wattage		Dimensions in Inches			Approx. Shipping Weight (lbs)
	Standard	Maximum	A	B	C	
Compact Models						
	120V	240V				
ES6-6-SOMS-K	1650	3000	15-1/4	10-3/4	14-1/4	35
ES6-10-SOMS-K	1650	6000	18-1/4	12-1/4	16	41
ES6-20-SOMS-K	2500	6000	24-3/4	18-5/8	18	68
ES6-20-SOMT-K	2500	6000	31-5/8	25-3/4	16	68
Lowboy Side-Connect Model						
	240V					
EN6-30-DOMBS*	4500	6000	30	21-3/4	22	101
EN6-30-DOMS	4500	6000	31-1/4	21-3/4	24	115
EN6-40-DOMBS*	4500	6000	31-3/4	24	24	118
EN6-40-DOMBSW*	-	4000	31-3/4	24	24	118
EN6-40-DOMS	4500	6000	33-1/2	24	26	118
EN6-40-DOMSW	-	4000	33-1/2	24	26	118
Table Top Model						
	240V					
EN6-38-2OTT	4500	5500	36	24	25	150
Point-Of-Use-Models						
	120V					
ES6-2-SMT	1440 @ 120V		18-1/2	13-1/4	12 1/4	17
ES6-4-SMT	1440 @ 120V		23 1/4	13-1/4	12 1/4	20
ES6-6-SMT	1440 @ 120V		24 1/4	16	15	24

*Models ship with a supplied insulation blanket. When ordering models EN6-40-DOMS or EN6-40-DOMSB the model number will change for wattages of 4kW to 1kW. The new model number will include a "W" suffix (example: EN6-40-DOMBSW). Dimensions and specifications subject to change without notice in accordance with our policy of continuous product improvement.

PUMP-MATE™



SPMD Series – Pre-Pressurized Diaphragm Tanks

2 THROUGH 119-GALLON CAPACITIES IN FREE-STANDING, IN-LINE OR HORIZONTAL DESIGNS

DURABLE BUTYL RUBBER PARABOLIC DIAPHRAGM

POWDER COATED LINING BONDED TO TANK SHELL, PROTECTS AGAINST RUST

ROTATING CORROSION-RESISTANT BASE ON FREE-STANDING MODELS ASSURES STABILITY

TANKS ARE CERTIFIED TO NSF/ANSI STANDARD 61-G AND 372 LISTED AND ARE IN COMPLIANCE WITH CALIFORNIA AND VERMONT'S NO-LEAD LEGISLATION

5-YEAR LIMITED WARRANTY

- For complete information, consult written warranty or go to statewaterheaters.com



SSB Series – Pre-Pressurized Diaphragm Tanks

2 THROUGH 119-GALLON CAPACITIES IN FREE-STANDING, IN-LINE OR HORIZONTAL DESIGNS

DURABLE BUTYL RUBBER PARABOLIC DIAPHRAGM

POWDER COATED LINING BONDED TO TANK SHELL, PROTECTS AGAINST RUST

TANKS ARE CERTIFIED TO NSF/ANSI STANDARD 61-G AND 372 LISTED AND ARE IN COMPLIANCE WITH CALIFORNIA AND VERMONT'S NO-LEAD LEGISLATION

Rust-Guard NO-WELD STEEL BASE

5-YEAR LIMITED WARRANTY

- For complete information, consult written warranty or go to statewaterheaters.com

NSF

Certified to NSF/ANSI 61-G and 372

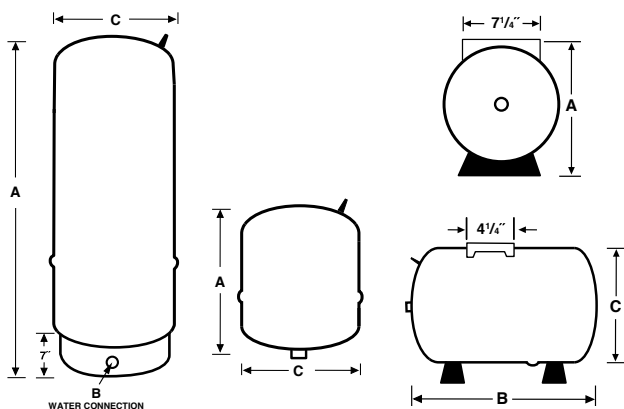

	Model Number	Volume (Gallons)	Dimensions in Inches			Weight (lbs)
			"A" Overall Height	"B" To Center of Water Inlet	"C" Diameter	
SPMD Series Free Standing Plastic Base	SPMD-14	14	24-3/4	2-1/4	15-3/8	25.5
	SPMD-20	20	32-3/4	2-1/4	15-3/8	30
	SPMD-31	31	45-1/2	2-1/4	15-3/8	40
	SPMD-36S	36	32-3/8	2-1/4	20	45
	SPMD-52	52	38-5/8	2-1/4	23-3/8	77
	SPMD-86	86	59	2-1/4	23-3/8	105
	SPMD-96	96	63-3/8	2-1/4	23-3/8	111
	SPMD-119	119.5	61-1/4	2-1/2	26	165
SSB Series Free Standing Metal Base	SSB20	20	32-3/4	2-1/4	15-3/8	30
	SSB32	32	45-1/2	2-1/4	15-3/8	40
	SSB36	36	32-3/8	2-1/4	20	45
	SSB52	52	38-5/8	2-1/4	23-3/8	77
	SSB65	65	46-5/8	2-1/4	23-3/8	87
	SSB86	86	59	2-1/4	23-3/8	105
	SSB119	119.5	61-1/4	2-1/2	26	165
SPMDI Series In-Line	SPMDI-2	2	10-3/16	-	8-1/4	5
	SPMDI-5	4.6	14-3/4	-	11	9
	SPMDI-7	7.3	21-1/16	-	11	14
	SPMDI-14	14	23-1/2	-	15-3/8	25
SPMDH Series Horizontal				"B" Overall Length		
	SPMDH-7	7.3	12-7/8	21-1/8	11	16
	SPMDH-14	14	17-3/8	21-3/4	15-3/8	25.5
	SPMDH-20	20	17-3/8	27-1/8	15-3/8	30

1" Female connection on 14, 20, and 36S gallons.

1-1/4" Female connections on 52, 86, 96, and 119 gallons.

SPMDI connection 3/4" Male. *SPMDI-14 1" male

SPMDH-7 connection 3/4" Male. *SPMDH-14, SPMDH-20 connection 1" Male

HEAVY-DUTY STATE PROLINE® GLASSLINED



Heavy-Duty Glasslined G Series

5-YEAR LIMITED WARRANTY

- UL Certified
- Max working pressure is 125 psig
- Anodic Protection
- For complete information, consult written warranty or go to statewaterheaters.com

G SERIES GLASSLINED PUMP TANKS

Model Number	Volume (Gallons)	Dimensions in Inches						Weight (lbs)
		A	B	C	D	E	F	
G-42-T	42	49	26	16-1/2	12	3	6	71
G-42-S	42	35-7/8	17	20	8	3	6	81
G-82	82	62-1/4	33	20	12	3	6	154
G-120	120	63	33	24	12	3	6	206

1-1/4" NPT Spud in head for alternate motor mount or retention tank connection

All tapping 1-1/4" Water Connections

1/4" pressure switch tapping on all models

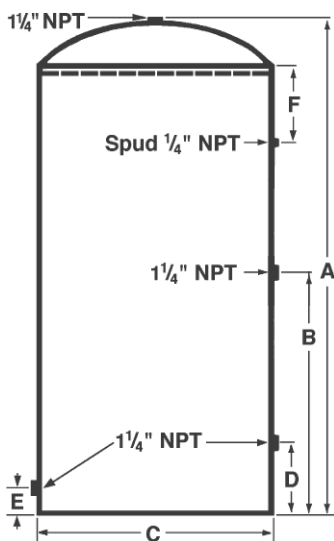

HEAVY-DUTY STATE PROLINE® GALVANIZED

Galvanized Tanks Z Series

1-YEAR LIMITED WARRANTY

- Vertical Tanks
- Maximum working pressure 75 psig
- NSF Certified 61G & 372
- For complete information, consult written warranty or go to statewaterheaters.com

VERTICAL TANKS Z SERIES 12 TO 120 GALLONS – FREE STANDING

Model Number	Volume (Gallons)	Dimensions in Inches					Weight (lbs)
		A	B	C	D	E	
Z-12	12	26-1/2	24	12	5	13	27
Z-21	21	26-7/8	24	16	5	13	45
Z-32	32	38-3/4	36	16	8	17	52
ZT-42	42	51	48	16	12	26	71
ZS-42	42	33-5/8	30	20	8	17	71
Z-82	82	63	60	20	12	33	114
Z-120	120	64-1/2	60	24	12	33	154

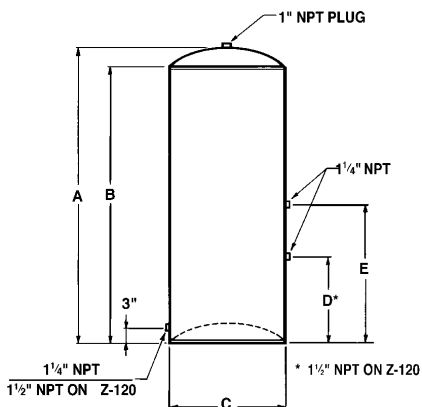

VERTICAL TANKS Z SERIES 220-480 GALLONS

Model Number	Volume (Gallons)	Dimensions in Inches									Weight (lbs)
		A	B	C	D	E	G	J	K	L	
Z-220	220	78	66	30	6	32	6	2-1/2	2	2	303
Z-315	315	79-1/2	66	36	6	32	7	2-1/2	2	2	416
Z-480	480	87	72	42	6	32	7-1/2	2-1/2	2	3	640

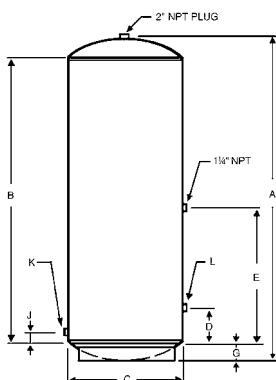

UNIVERSAL TANKS Z SERIES 525-900 GALLONS

Model Number	Volume (Gallons)	Dimensions in Inches								Weight (lbs)
		A	B	C	D	E	F	G	J	
ZU-525	525	131	114	36	6	56	2-1/2	2-1/2	2" NPT	685
ZU-900	900	161	144	42	14	69	4	4	3" NPT	1040

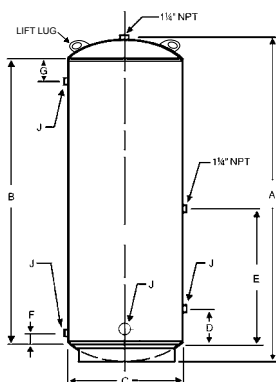

WATERGUARD™ & THERM-O-FLEX™



WATERGUARD™

POTABLE WATER HEATER EXPANSION TANKS

- For use with residential and commercial water heaters to a maximum of 180°
- Field-adjustable 38 psi air charge
- IAPMO approved (150 psig Models)
- Tanks are NSF Standard 61-G and 372 listed
- 5-year limited tank warranty



When used in potable applications

THERM-O-FLEX™

POTABLE WATER HEATER EXPANSION TANKS

- In-Line Series, Models ETC-7, ETC-14, 3/4" FPT
- Free Standing Series Models ETC-15 to ETC-36, 1" FPT
- ETC-52 to ETC-86, 1-1/4" FPT
- Tanks are NSF Standard 61-G and 372 listed
- 5-year limited warranty

For complete information, consult written warranty or go to statewaterheaters.com

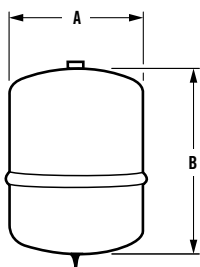

IN-LINE

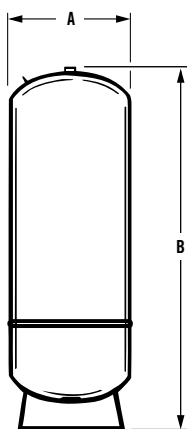

FREE-STANDING

Model Number	Maximum (PSIG) Working Pressure	Tank Volume (Gallons)	Maximum Accepted Volume (Gallons)			Connection NPT Size	A	B	Weight (lbs)
			20 PSI	40 PSI	60 PSI				
Waterguard™-Series (Potable Expansion Tanks - 5-Year Limited Warranty)									
ETC-10X	150	9.25	7.80	6.55	5.25	3/4	15-1/2	15-3/8	18
Therm-o-Flex™ Series (Potable Expansion Tanks - 5-Year Limited Warranty)									
ETC-7	100	7.27	4.6	N/A	N/A	3/4	21-1/16	11	14
ETC-14	100	14.6	10.5	8.0	5.6	3/4	23-1/2	15-3/8	25
ETC-15	100	14.6	10.5	8.0	5.6	1	24-3/4	15-3/8	25-1/2
ETC-20	100	20	13.5	10.1	6.7	1	32-3/4	15-3/8	30
ETC-36S	100	36	21	16.6	11.4	1	32-3/8	20	45
ETC-52	100	52	33.8	25.5	19.7	1-1/4	38-5/8	23-3/8	77
ETC-86	100	86	61.2	45.4	32.8	1-1/4	59	23-3/8	105

THERM-O-FLEX™



SPACE HEATING EXPANSION TANKS

FOR USE WITH RESIDENTIAL SPACE HEATING BOILERS IN CLOSED SYSTEMS

- Not for use with potable water heating systems
- Designed for in-line or free standing installation
- Combination models shipped with air vent and separator
- Field-adjustable 12 psi air charge
- Drawn-steel tank with butyl rubber parabolic diaphragm separates air and water
- Maximum temperature 240° F
- 100 psi maximum working pressure
- 1-year tank limited warranty
- For complete information, consult written warranty or go to statewaterheaters.com

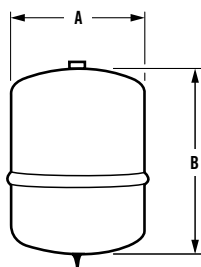

IN-LINE

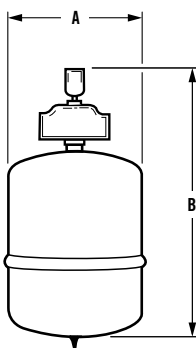

COMBINATION UNITS

Model Number	Tank Volume (Gallons)	Max. Acceptable Volume (Gallons) 20 PSIG	Dimensions in Inches		Shipping Weight (lbs)
			Height	Diameter	
Therm-o-Flex In-Line					
ET-2	1.86	1.53	10-3/16	8-1/4	5
ET-5	4.83	3.75	14-3/4	11	9
ET-7	7.27	4.6	21-1/16	11	14
ET-14	14.6	10.5	21-3/4	15-3/8	22
Therm-o-Flex Combination Units*					
ET-2V-1	1.86	1.53	20-11/16	8-1/4	10
ET-2V-2	1.86	1.53	20-11/16	8-1/4	10
ET-5V-1	4.83	3.75	25-1/8	11	13
ET-5V-2	4.83	3.75	25-1/8	11	13
ET-7V-1	7.27	4.6	31-3/8	11	16
ET-7V-2	7.27	4.6	31-3/8	11	16

*Combination Units with Air Vent and Air Separator

All Models: 100 psig Maximum Working Pressure

All In-Line Models have 1/2" MPT connections

Combination Units Air Vent Connection Sizes: ET-2V-1, ET-5V-1, ET-7V-1 have 1" female connection

Combination Units Air Vent Connection Sizes: ET-2V-2, ET-5V-2, ET-7V-2 have 1-1/4" female connection

PROLINE® XE WITH X3® SCALE PREVENTION TECHNOLOGY

PROLINE® XE
BEST



Indoor



Outdoor



ANSI Z21.10.3 CSA 4.3

*Select models

X3 SCALE PREVENTION TECHNOLOGY (PATENT PENDING)

- No annual descaling required
- No scale buildup means the heater maintains like-new performance longer

ENERGY STAR® QUALIFIED* DURABLE HEAT EXCHANGER

- Primary heat exchanger is constructed of a commercial-grade copper that is more resilient to corrosion. Copper is 25x better at heat transfer than Stainless Steel, thus stabilizing outgoing water temperatures quicker
- Secondary heat exchanger is made of 316L Stainless Steel to protect against corrosion

QUALIFIED AS LEAD FREE UNDER THE SAFE DRINKING WATER ACT

SAFETY FEATURES

- Exhaust & Water Temperature Safety Control
- Overheat Cut-Off Fuse
- Air-Fuel Ratio (AFR) Sensor

INTERNAL FREEZE PROTECTION SYSTEM

RECIRC CAPABLE

- Tankless water heaters with X3 Technology are approved to work with an external recirculation pump and cross-over valve. See training manual for full details

POWER DIRECT VENT DESIGN

- Category III or IV venting can be used
- Exhaust, 3" PVC up to 70'; 4" PVC up to 100'
- Provides flexible venting with PVC, CPVC, polypropylene, or ABS Pipe for Intake and Exhaust (solid core only)

ACCESSORIES

- Pipe Cover
- Neutralizer Kit
- X3 Freeze Protection Kit
- Concentric Termination
- Recess Box

WARRANTY

- No hardwater exclusions in the industry's first "peace of mind" limited warranty
- 15-year limited warranty on heat exchanger in residential applications
- 5-year limited warranty on all parts in residential applications
- 1-year limited warranty on heat exchanger and parts in commercial applications
- For complete information, consult written warranty or go to statewaterheaters.com

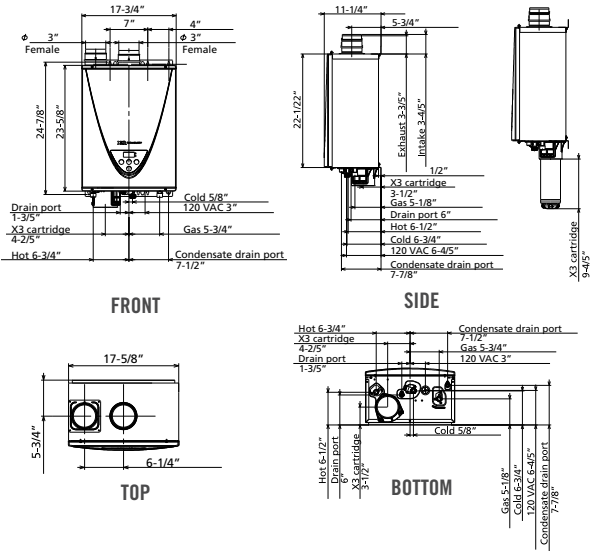

Model Number	Type	Gas Consumption Input		Supply Gas Pressure		UEF
		Minimum UEF BTU/H	Maximum BTU/H	Minimum in. W.C.	Maximum in. W.C.	
Indoor Models						
GTS-240X3-NIH	Natural	15,000	160,000	4.0	10.5	0.94
GTS-240X3-PIH	Propane	13,000	160,000	8.0	14.0	0.94
GTS-340X3-NIH+	Natural	15,000	180,000	4.0	10.5	0.95
GTS-340X3-PIH+	Propane	13,000	180,000	8.0	14.0	0.95
GTS-540X3-NIH	Natural	15,000	199,000	4.0	10.5	0.93
GTS-540X3-PIH	Propane	13,000	199,000	8.0	14.0	0.93
Outdoor Models						
GTS-240X3-NEH+	Natural	15,000	160,000	4.0	10.5	0.95
GTS-240X3-PEH+	Propane	13,000	160,000	8.0	14.0	0.95
GTS-340X3-NEH	Natural	15,000	180,000	4.0	10.5	0.94
GTS-340X3-PEH	Propane	13,000	180,000	8.0	14.0	0.94
GTS-540X3-NEH+	Natural	15,000	199,000	4.0	10.5	0.95
GTS-540X3-PEH+	Propane	13,000	199,000	8.0	14.0	0.95

Maximum GPM*	Hot/Cold Connections	Gas Connection	Dimensions in Inches				Approx. Shipping Weight (lbs)
			Height	Width	Depth	Height with Cartridge	
Indoor Models							
6.6	3/4" NPT	3/4" NPT	23-5/8	17-3/4	11-1/4	35-9/16	72
6.6	3/4" NPT	3/4" NPT	23-5/8	17-3/4	11-1/4	35-9/16	72
8	3/4" NPT	3/4" NPT	23-5/8	17-3/4	11-1/4	35-9/16	72
8	3/4" NPT	3/4" NPT	23-5/8	17-3/4	11-1/4	35-9/16	72
10	3/4" NPT	3/4" NPT	23-5/8	17-3/4	11-1/4	35-9/16	73
10	3/4" NPT	3/4" NPT	23-5/8	17-3/4	11-1/4	35-9/16	73
Outdoor Models							
6.6	3/4" NPT	3/4" NPT	23-5/8	17-3/4	11-1/4	35-9/16	71
6.6	3/4" NPT	3/4" NPT	23-5/8	17-3/4	11-1/4	35-9/16	71
8	3/4" NPT	3/4" NPT	23-5/8	17-3/4	11-1/4	35-9/16	71
8	3/4" NPT	3/4" NPT	23-5/8	17-3/4	11-1/4	35-9/16	71
10	3/4" NPT	3/4" NPT	23-5/8	17-3/4	11-1/4	35-9/16	73
10	3/4" NPT	3/4" NPT	23-5/8	17-3/4	11-1/4	35-9/16	73

15-150 PSI Water Pressure. 40 PSI or above recommended for maximum flow.

*Current numbers based on factory testing; 0.5 GPM for activation; 0.4 GPM required for continuous fire after initial ignition. Indoor models are certified from sea level to 10,100 ft. elevations. Outdoor models are certified from sea level to 6,000 ft. elevation.

*ENERGY STAR® Qualified

PROLINE® XE CONDENSING WITH RECIRCULATION PUMP

PROLINE® XE
BEST



Indoor



Outdoor

Meets SCAQMD
Rule 1146.2



ANSI Z21. 10.3

CSA 4.3

*Select models

INTEGRATED RECIRCULATION PUMP

- Simplify installation by eliminating added time and money spent sourcing and installing pump and controls. Integrated front panel controls are easy to view and set.
- 1/2" pipe - 200'
- 3/4" pipe - 500'

PUMP CONTROLS

- Included with heater
- Two timer settings
- Adjustable differential settings

ENERGY STAR® QUALIFIED*

ULTRA-LOW NO_x EMISSIONS

- Complies with SCAQMD 1146.2 NO_x emission requirements of 14 ng/J or 20 PPM

INDOOR MODELS

- Include integrated temperature and pump controls with advanced diagnostics that simplify installation and troubleshooting
- Factory-installed power cord

OUTDOOR MODELS

- Includes a wall mount temperature remote controller and advanced diagnostics to simplify troubleshooting

COMMON VENT INDOOR MODELS UP TO 8 HEATERS

- Easy-link with up to three 540H condensing tankless heaters to increase flow capacity

SAFETY FEATURES

- Air-Fuel ratio (AFR) sensor
- Exhaust & water temperature safety control
- Overheat cut-off fuse

INTERNAL FREEZE PROTECTION

WARRANTY

- 15-year limited warranty on heat exchanger in residential applications
- 6-year limited warranty on heat exchanger in commercial applications
- 5-year limited warranty on all parts
- For complete information, consult written warranty or go to statewaterheaters.com

INDOOR MODEL

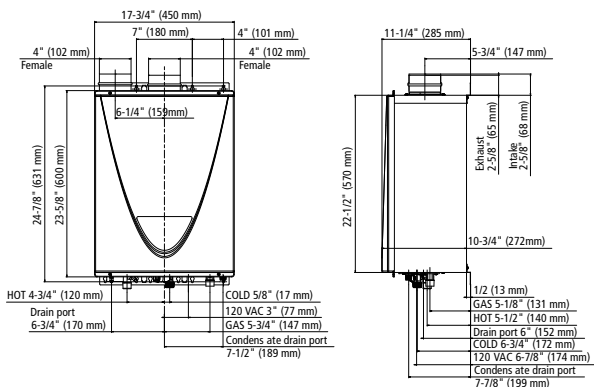

OUTDOOR MODEL

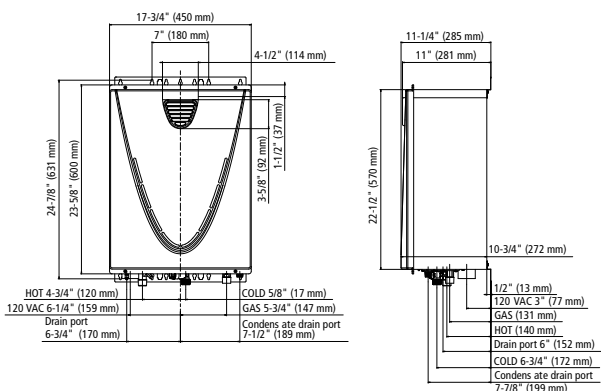

Model Number*	Type	Gas Consumption Input		Inlet Gas Pressure***		Indoor Model UEF	Outdoor Model UEF+	Approx Shipping Weight (lbs)
		Minimum** (BTU/H)	Maximum (BTU/H)	Minimum (in. W.C.)	Maximum (in. W.C.)			
GTS-540P-NIH	Natural	15,000	199,000	4.0	10.5	0.93	0.95	71

Model Number*	Connections		Sizing Chart (Number of Showers)		Clearances (in.)			
	Water	Gas	Cold Climate†	Warm Climate‡	Top	Bottom	Side	Front
GTS-540P-NIH	3/4" NPT	3/4" NPT	3	4.5	12	12	3	4

* For outdoor models, change "NIH" to "NEH". For propane models, change "N" to "P".

** For propane models, minimum is 13,000.

*** For propane models, minimum inlet gas pressure is 8.0 in. W.C. and maximum inlet gas pressure is 14.0 in. W.C.

† Cold climate represents 70°F temperature rise.

‡ Warm climate represents 50°F temperature rise.

*GTS-540P-NIH and GTS-540P-PEH are ENERGY STAR® Qualified

PROLINE® XE CONDENSING HIGH EFFICIENCY

PROLINE® XE
BEST



Indoor



Outdoor



Meets SCAQMD
Rule 1146.2
NSF



ANSI Z21. 10.3

CSA 4.3

CONDENSING TECHNOLOGY PROVIDES UP TO 0.91 UEF

ULTRA-LOW NO_x EMISSIONS

- Complies with SCAQMD 1146.2 NO_x emission requirements of 14 ng/J or 20 PPM

COPPER PRIMARY HEAT EXCHANGER

- 25x better heat transfer than stainless steel thus stabilizing outgoing water temperature quicker and reducing pressure drop across the heat exchanger

SECONDARY HEAT EXCHANGER

- Marine-Grade 316L stainless steel to protect against corrosion

INDOOR MODELS

- Include a built-in temperature controller and advanced diagnostics to simplify troubleshooting
- Factory-installed power cord included

OUTDOOR MODELS

- Include a wall mount temperature remote controller and advanced diagnostics to simplify troubleshooting

ELECTRONIC IGNITION—NO PILOT LIGHT

SAFETY FEATURES:

- Air Fuel Ratio (AFR) Sensor
- Exhaust and water temperature safety control
- Overheat cut-off fuse

INTERNAL FREEZE PROTECTION SYSTEM

POWER VENT OR POWER DIRECT VENT DESIGN

WARRANTY

- 15-year limited warranty on heat exchanger in residential applications
- 6-year limited warranty on heat exchanger in commercial applications
- 5-year limited warranty on all parts
- For complete information, consult written warranty or go to statewaterheaters.com

INDOOR MODEL

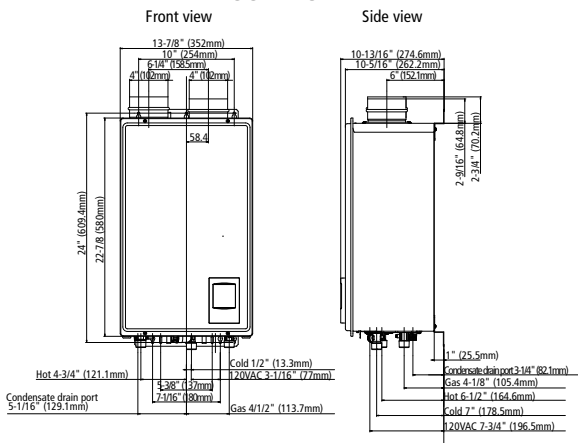

OUTDOOR MODEL

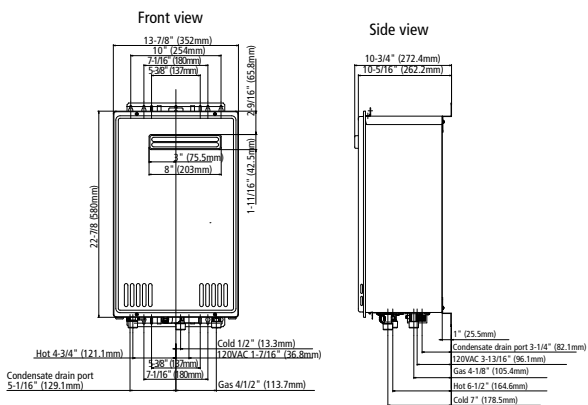

Model Number*	Type	Gas Consumption Input		Inlet Gas Pressure***		Indoor Model UEF	Outdoor Model UEF
		Minimum** (BTU/H)	Maximum (BTU/H)	Minimum (in. W.C.)	Maximum (in. W.C.)		
GTS-140-NIH	Natural	15,000	120,000	4.0	10.5	0.90	0.91

Model Number*	Connections		Sizing Chart (Number of Showers)		Clearances (in.)				Approx Shipping Weight (lbs)
	Water	Gas	Cold Climate†	Warm Climate‡	Top	Bottom	Side	Front	
GTS-140-NIH	3/4" NPT	1/2" NPT	1.5	2.5	12	12	3	4	54

*For outdoor models, change "NIH" to "NEH". For propane models, change "N" to "P".

**For propane models, minimum is 13,000.

***For propane models, minimum inlet gas pressure is 8.0 in. W.C. and maximum inlet gas pressure is 14.0 in. W.C.

† Cold climate represents 70°F temperature rise.

‡ Warm climate represents 50°F temperature rise.

PROLINE® XE CONDENSING HIGH EFFICIENCY

PROLINE® XE
BEST



Indoor



Outdoor



ANSI Z21. 10.3

CSA 4.3

*Select models

ENERGY STAR® QUALIFIED*

CONDENSING TECHNOLOGY PROVIDES UP TO 0.95 UEF

ULTRA-LOW NO_x EMISSIONS

- Complies with SCAQMD Rule 1146.2 NO_x emission requirements of 14 ng/J or 20 PPM

MAXIMUM FLOW RATES UP TO 10.0 GPM HEAT EXCHANGER

- Primary heat exchanger of the GTS-540 is constructed of a commercial-grade copper that is more resilient to erosion. Copper is 25x better at heat transfer than stainless steel thus stabilizing outgoing water temperatures quicker and reducing pressure drop across the heat exchanger.
- Secondary heat exchanger is made of marine-grade 316L stainless steel to protect against corrosion

INDOOR MODELS

- Include integrated temperature controls and advanced diagnostics to simplify troubleshooting
- Include factory-installed power cords

OUTDOOR MODELS

- Include wall mount temperature remote controller and advanced diagnostics to simplify troubleshooting

COMMON VENT INDOOR MODELS UP TO 8 UNITS

540H CAN BE USED IN BOTH RESIDENTIAL AND COMMERCIAL APPLICATIONS

- Easy-link up to 4 heaters
- Multi-link up to 20 heaters

SAFETY FEATURES

- Air-fuel Ratio (AFR) Sensor
- Exhaust and water temperature safety control
- Overheat cut-off fuse

INTERNAL FREEZE PROTECTION SYSTEMS

POWER VENT OR POWER DIRECT VENT DESIGN WARRANTY

- 15-year limited warranty on heat exchanger in residential applications
- 6-year limited warranty on heat exchanger in commercial applications
- 5-year limited warranty on all parts
- For complete information, consult written warranty or go to statewaterheaters.com

INDOOR MODEL

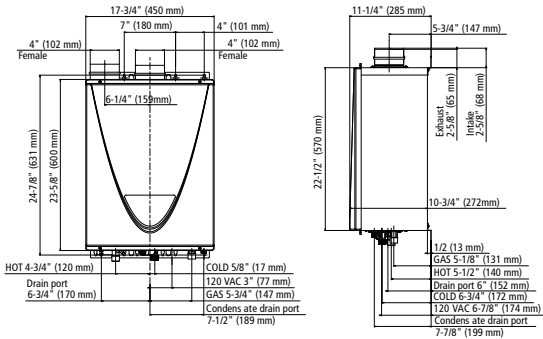

OUTDOOR MODEL

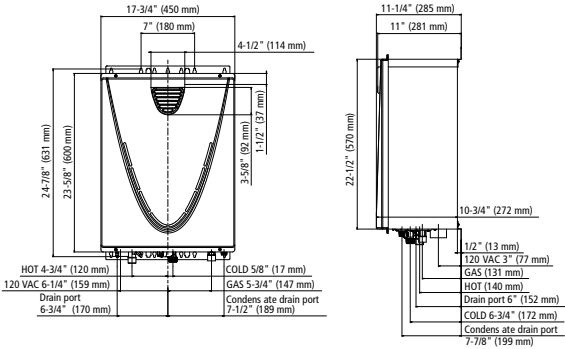

Model Number*	Type	Gas Consumption Input		Inlet Gas Pressure***		Indoor Model UEF	Outdoor Model UEF	Approx Shipping Weight (lbs)
		Minimum** (BTU/H)	Maximum (BTU/H)	Minimum (in. W.C.)	Maximum (in. W.C.)			
GTS-240-NIH	Natural	15,000	160,000	4.0	10.5	0.94	0.95+	71
GTS-340-NIH	Natural	15,000	180,000	4.0	10.5	0.95+	0.94	71
GTS-540-NIH	Natural	15,000	199,000	4.0	10.5	0.93	0.95+	71

Model Number*	Connections		Sizing Chart (Number of Showers)		Clearances (in.)			
	Water	Gas	Cold Climate†	Warm Climate‡	Top	Bottom	Side	Front
GTS-240-NIH	3/4" NPT	3/4" NPT	2.5	4	12	12	3	4
GTS-340-NIH	3/4" NPT	3/4" NPT	2.5	4	12	12	3	4
GTS-540-NIH	3/4" NPT	3/4" NPT	3	4.5	12	12	3	4

*For outdoor models, change "NIH" to "NEH". For propane models, change "N" to "P".

**For propane models, minimum is 13,000.

***For propane models, minimum inlet gas pressure is 8.0 in. W.C. and maximum inlet gas pressure is 14.0 in. W.C.

† Cold climate represents 70°F temperature rise.

‡ Warm climate represents 50°F temperature rise.

*ENERGY STAR® Qualified

PROLINE® XE NON-CONDENSING CONCENTRIC VENT

PROLINE® XE
BEST



Meets SCAQMD
Rule 1146.2



ANSI Z21.10.3



(510c model only)

CONCENTRIC VENT DESIGN

- Power direct vent
- Vertical or horizontal venting up to 43'

FIELD CONVERTIBLE FROM NATURAL GAS TO PROPANE

ULTRA-LOW NO_x EMISSIONS

- Complies with SCAQMD Rule 1146.2 NO_x emission requirements of 14 ng/J or 20 PPM

MAXIMUM FLOW RATES UP TO 10.0 GPM

PRIMARY HEAT EXCHANGER

- Primary heat exchanger of the GTS-510C is constructed of a commercial-grade copper that is more resilient to erosion. Copper is 25x better at heat transfer than stainless steel thus stabilizing outgoing water temperatures quicker and reducing pressure drop across the heat exchanger.

INDOOR MODELS ONLY

- Include integrated temperature controls and advanced diagnostics to simplify troubleshooting
- Include factory-installed power cords

GTS-510C CAN BE USED IN BOTH RESIDENTIAL AND COMMERCIAL APPLICATIONS

- Easy-Link up to 4 units
- Multi-Link up to 20 units

SAFETY FEATURES

- Air-Fuel Ratio (AFT) sensor
- Water temperature safety control
- Overheat cut-off fuse

INTERNAL FREEZE PROTECTION

WARRANTY

- 15-year limited warranty on heat exchanger in residential applications
- 6-year limited warranty on heat exchanger in commercial applications
- 5-year limited warranty on all parts
- For complete information, consult written warranty or go to statewaterheaters.com

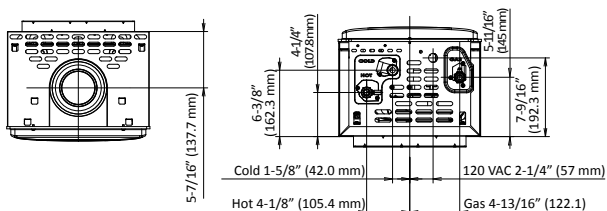

Top view

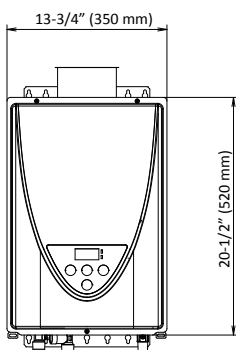

Front view

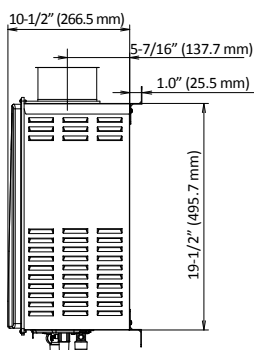

Side view

Model Number*	Gas Consumption Input		Inlet Gas Pressure**		UEF	Connections	
	Minimum (BTU/H)	Maximum (BTU/H)	Minimum (in. W.C.)	Maximum (in. W.C.)		Water	Gas
GTS-310C-NI	15,000	190,000	4.0	10.5	0.81	3/4" NPT	3/4" NPT
GTS-510C-NI	15,000	199,000	4.0	10.5	0.81	3/4" NPT	3/4" NPT

Model Number*	Sizing Chart (Number of Showers)		Clearances (in.)				Approx. Shipping Weight (lbs.)
	Cold Climate†	Warm Climate‡	Top	Bottom	Side	Front	
GTS-310C-NI	2.5	3.5	12	12	3	4	55
GTS-510C-NI	2.5	3.5	12	12	3	4	55

*Indoor models only. Units are field convertible from natural gas to propane with supplied conversion kit.

**For propane models, minimum inlet gas pressure is 8.0 in. W.C. and maximum inlet gas pressure is 14.0 in. W.C.

† Cold climate represents 70°F temperature rise

‡ Warm climate represents 50°F temperature rise

TANKLESS NON-CONDENSING ULTRA-LOW NO_x



Indoor



Outdoor



(510U model only)



ANSI Z21. 10.3

ULTRA-LOW NO_x EMISSIONS

- Complies with SCAQMD Rule 1146.2 NO_x emission requirements of 14 ng/J or 20 PPM

FIELD CONVERTIBLE FROM NATURAL GAS TO PROPANE.

MAXIMUM FLOW RATES UP TO 10.0 GPM

COPPER PRIMARY HEAT EXCHANGER

- Primary heat exchanger of the GTS-510U is constructed of a commercial-grade copper that is more resilient to erosion. Copper is 25x better at heat transfer than stainless steel thus stabilizing outgoing water temperatures quicker and reducing pressure drop across the heat exchanger.

INDOOR MODELS

- Include integrated temperature controls and advanced diagnostics to simplify troubleshooting
- Include factory-installed power cords

OUTDOOR MODELS

- Include a wall mount temperature remote controller and advanced diagnostics to simplify troubleshooting

GTS-510U CAN BE USED IN BOTH RESIDENTIAL AND COMMERCIAL APPLICATIONS

- Easy-Link up to 4 units
- Multi-Link up to 20 units

SAFETY FEATURES

- Air-Fuel Ratio (AFR) Sensor
- Exhaust and water temperature safety control
- Overheat cut-off fuse

INTERNAL FREEZE PROTECTION

POWER VENT OR POWER DIRECT VENT DESIGN

WARRANTY

- 15-year limited warranty on heat exchanger in residential applications
- 6-year limited warranty on heat exchanger in commercial applications
- 5-year limited warranty on all parts
- For complete information, consult written warranty or go to statewaterheaters.com

INDOOR MODEL

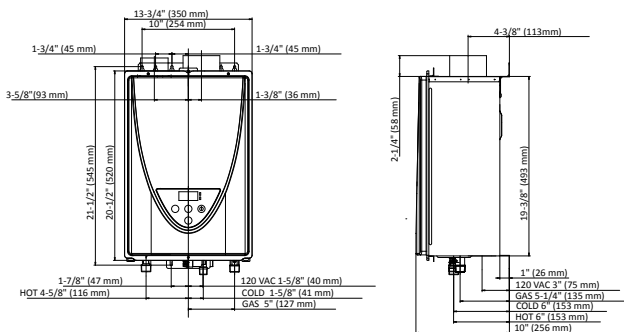

OUTDOOR MODEL

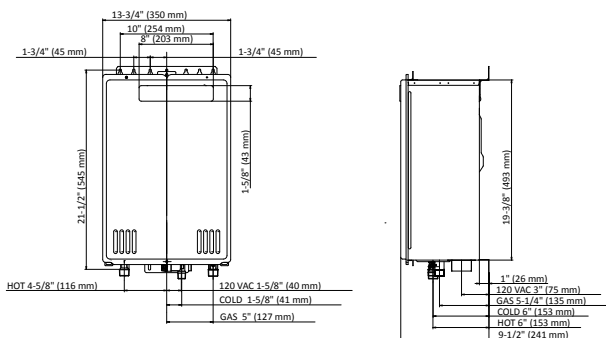

Model Number*	Type	Gas Consumption Input		Inlet Gas Pressure**		Indoor Model UEF	Outdoor Model UEF	Connections	
		Minimum (BTU/H)	Maximum (BTU/H)	Minimum (in. W.C.)	Maximum (in. W.C.)			Water	Gas
GTS-110U-I	Natural	15,000	140,000	4.0	10.5	0.81	0.81	3/4" NPT	3/4" NPT
GTS-310U-I	Natural	15,000	190,000	4.0	10.5	0.81	0.81	3/4" NPT	3/4" NPT
GTS-510U-I	Natural	15,000	199,000	4.0	10.5	0.81	0.81	3/4" NPT	3/4" NPT

Model Number*	Sizing Chart (Number of Showers)		Clearances (in.)				Approx Shipping Weight (lbs)
	Cold Climate†	Warm Climate‡	Top	Bottom	Side	Front	
GTS-110U-I	1.5	2.5	12	12	3	4	34
GTS-310U-I	2.5	3.5	12	12	3	4	34
GTS-510U-I	2.5	3.5	12	12	3	4	35

*For outdoor models, change "I" to "E". Units are field convertible from natural gas to propane with supplied conversion kit.

**For propane, minimum inlet gas pressure is 8.0 in. W.C. and maximum inlet gas pressure is 14.0 in. W.C.

† Cold climate represents 70°F temperature rise.

‡ Warm climate represents 50°F temperature rise.

TANKLESS NON-CONDENSING HEAVY-DUTY



COMMERCIAL-GRADE COPPER HEAT EXCHANGER (NON-ASME MODELS)

ASME MODELS AVAILABLE

5" CATEGORY III STAINLESS STEEL VENTING

VERTICAL OR HORIZONTAL VENTING INSTALLATIONS

POWER VENT OR CONVERTIBLE TO POWER DIRECT VENT

ELECTRONIC IGNITION

LOW NO_x EMISSIONS

COMBINED INDOOR/OUTDOOR MODELS

EASY-LINK UP TO 4 UNITS

MULTI-LINK UP TO 10 UNITS

WARRANTY

- 6-year limited warranty on heat exchanger
- 5-year limited warranty on all parts
- For complete information, consult written warranty or go to statewaterheaters.com

PROLINE® XE COMBI BOILER



Meets SCAQMD
Rule 1146.2



Low Level Output



AHRI CERTIFIED
www.ahridirectory.org

ANSI Z21.13 • CSA 4.9

INDOOR INSTALLATION ONLY

ULTRA-LOW NOX EMISSIONS

- Complies with SCAQMD Rule 1146.2 NOx Emission Requirements Of 14 ng/J or 20 PPM

MODULATING BURNER WITH 10:1 TURNDOWN RATIO

- Continuously adjusts the firing rate to match demand for maximum comfort and system efficiency

USER FRIENDLY CONTROLS

- Programming the combi boiler takes less than two minutes and uses plain text rather than number codes

QUICKER DOMESTIC HOT WATER RESPONSE

- Advanced control technology prevents the cold water sandwich often found with other combi boilers

POWER DIRECT VENT DESIGN

- Two-pipe sealed combustion system uses outside air, eliminating problems caused by insufficient indoor ventilation

DOMESTIC HOT WATER FLOW RATE UP TO 4.8 GPM AT 77°F TEMPERATURE RISE

MAXIMUM WORKING PRESSURE

- 50 PSI max pressure (boiler); 150 PSI max pressure (DHW)

WARRANTY

- 10-year limited warranty on heat exchanger in residential applications
- 5-year warranty on all parts
- For complete information, consult written warranty or go to statewaterheaters.com

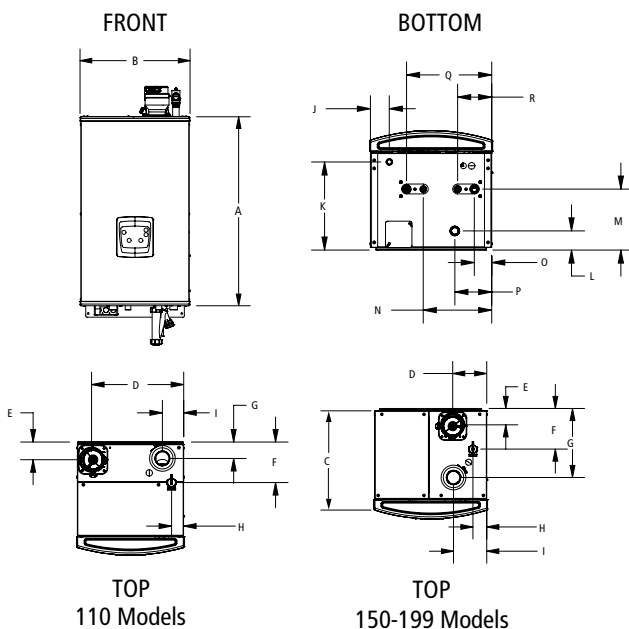

Model Number*	Gas Consumption Input		AFUE%	Heating Capacity BTU/H	Net AHRI Rating BTU/H**
	Minimum BTU/H	Maximum BTU/H			
SCB-110S-N	11,000	110,000	95.0	102,000	89,000
SCB-150S-N	15,000	150,000	95.0	139,000	121,000
SCB-199S-N	19,900	199,000	95.0	185,000	161,000

Minimum in. W.C.†	Maximum in. W.C.	GPM at 77°F Rise	Water Connections		Gas Connection	Approx. Shipping Weight (lbs)
			Space Heating	DHW		
4.0	14.0	2.6	1" NPT	3/4" NPT	1/2" NPT	139
4.0	14.0	3.6	1" NPT	3/4" NPT	1/2" NPT	142
4.0	14.0	4.8	1" NPT	3/4" NPT	1/2" NPT	159

Model Number*	Dimensions		
	A	B	C
SCB-110S-N	32-1/2"	17-1/4"	18"
SCB-150S-N	32-1/2"	18-3/4"	18"
SCB-199S-N	32-1/2"	18-3/4"	18"

*S Models can operate up to 4,500'. For high altitude (3,000' - 9,600'), change S to H. For liquid propane (LP), change N to P.

**The Net AHRI Water Ratings shown are based on a piping and pickup allowance of 1.15.

The manufacturer should be consulted before selecting a boiler for installations having unusual piping and pickup requirements, such as intermittent system operation, extensive piping systems, etc.

†For LP, minimum supply pressure is 8.0 in. W.C.

The ratings have been determined under the provisions governing forced draft boilers.

TANKLESS COMMERCIAL RACK SYSTEM



WALL MOUNT

MULTIPLE DESIGN AND INSTALLATION CONFIGURATIONS

- Wall mount, free standing in-line, and free standing back-to-back designs
- Indoor and outdoor rack designs
- Uses the 540H high efficiency condensing tankless heaters

EXPANDABLE

- Up to 1,194,000 BTU on a single rack system
- Able to link up to 20 heaters together with Multi-Link system

REDUNDANCY

- Multiple combustion systems provide piece of mind
- Easily isolate a unit for maintenance which extends the life of the heaters

LIGHTWEIGHT

- Anodized aluminum frame
- Utilizes the industry's lightest 199,000 BTU high efficiency condensing tankless heater

EASY FIELD INSTALLATION

- Reduce installation costs with three simple connections (cold water, hot water, and gas)
- Ultra-Low NOx Emissions
- Complies with SCAQMD Rule 1146.2 NOx emission requirements of 14 ng/J or 20 PPM

WARRANTY

- 6-year limited warranty on heat exchanger
- 5-year limited warranty on tankless parts
- 1-year limited warranty on rack parts
- For complete information, consult written warranty or go to statewaterheaters.com



FREE-STANDING



BACK-TO-BACK

Model Number	Number of Heaters	Btuh Input		Max Flow (GPM)		
		Min	Max	@ 50°F Rise	@ 70°F Rise	@ 100°F Rise
Wall Mount						
SCI-CRS-22WM-N	2	15,000	398,000	15.2	10.8	7.6
SCI-CRS-22WM-P	2	13,000	398,000	15.2	10.8	7.6
SCI-CRS-23WM-N	2	15,000	398,000	15.2	10.8	7.6
SCI-CRS-23WM-P	2	13,000	398,000	15.2	10.8	7.6
SCI-CRS-33WM-N	3	15,000	597,000	22.8	16.2	11.4
SCI-CRS-33WM-P	3	13,000	597,000	22.8	16.2	11.4
SCI-CRS-44WM-N	4	15,000	796,000	30.4	21.6	15.2
SCI-CRS-44WM-P	4	15,000	796,000	30.4	21.6	15.2
Freestanding						
SCI-CRS-24IL-N	2	15,000	398,000	15.2	10.8	7.6
SCI-CRS-24IL-P	2	13,000	398,000	15.2	10.8	7.6
SCI-CRS-26IL-N	2	15,000	398,000	15.2	10.8	7.6
SCI-CRS-26IL-P	2	13,000	398,000	15.2	10.8	7.6
SCI-CRS-36IL-N	3	15,000	597,000	22.8	16.2	11.4
SCI-CRS-36IL-P	3	13,000	597,000	22.8	16.2	11.4
Back-to-Back						
SCI-CRS-24B2B-N	2	15,000	398,000	15.2	10.8	7.6
SCI-CRS-24B2B-P	2	13,000	398,000	15.2	10.8	7.6
SCI-CRS-34B2B-N	3	15,000	597,000	22.8	16.2	11.4
SCI-CRS-34B2B-P	3	13,000	597,000	22.8	16.2	11.4
SCI-CRS-36B2B-N	3	15,000	597,000	22.8	16.2	11.4
SCI-CRS-36B2B-P	3	13,000	597,000	22.8	16.2	11.4
SCI-CRS-44B2B-N	4	15,000	796,000	30.4	21.6	15.2
SCI-CRS-44B2B-P	4	13,000	796,000	30.4	21.6	15.2
SCI-CRS-46B2B-N	4	15,000	796,000	30.4	21.6	15.2
SCI-CRS-46B2B-P	4	13,000	796,000	30.4	21.6	15.2
SCI-CRS-56B2B-N	5	15,000	995,000	38	27	19
SCI-CRS-56B2B-P	5	13,000	995,000	38	27	19
SCI-CRS-66B2B-N	6	15,000	1,194,000	45.6	32.4	22.8
SCI-CRS-66B2B-P	6	13,000	1,194,000	45.6	32.4	22.8

*For outdoor models, change SCI to SCO

TANKLESS COMMERCIAL RACK SYSTEM

(CONTINUED)

WALL MOUNT

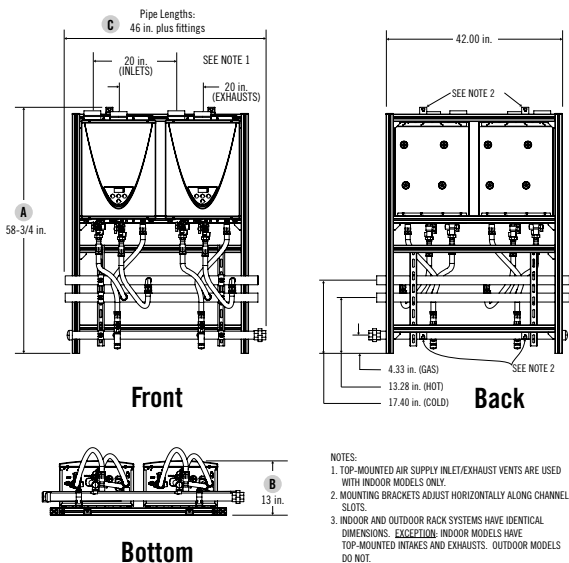

FREE-STANDING

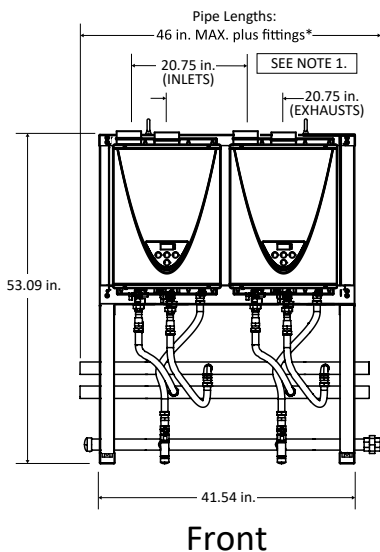

*Fittings to be field supplied.

BACK-TO-BACK

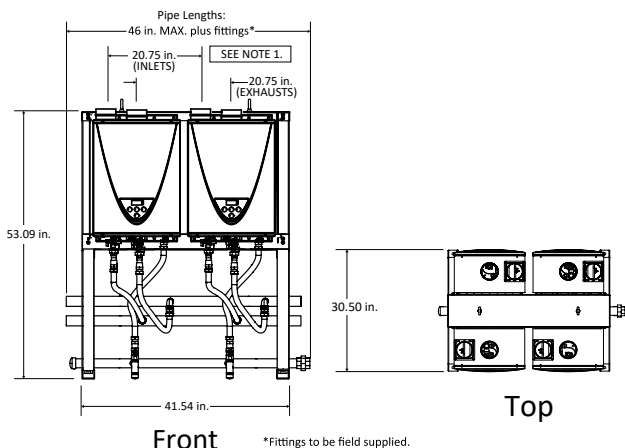

NOTES:

1. TOP-MOUNTED AIR SUPPLY INLET/EXHAUST VENT ARE USED WITH INDOOR MODELS ONLY.
2. INDOOR AND OUTDOOR RACK SYSTEMS HAVE IDENTICAL DIMENSIONS. EXCEPTION: INDOOR MODELS HAVE TOP-MOUNTED INTAKES AND EXHAUSTS. OUTDOOR MODELS DO NOT.

Model Number	Dimensions (in)			Approx Shipping Weight (lbs)
	A Length	B Width	C Height	
Wall Mount				
SCI-CRS-22WM-N	46	13.02	57	240
SCI-CRS-22WM-P	46	13.02	57	240
SCI-CRS-23WM-N	66	13.02	57	250
SCI-CRS-23WM-P	66	13.02	57	250
SCI-CRS-33WM-N	66	13.02	57	350
SCI-CRS-33WM-P	66	13.02	57	350
SCI-CRS-44MW-N	87.54	13.02	57	550
SCI-CRS-44MW-P	87.54	13.02	57	550
Freestanding				
SCI-CRS-24IL-N	46	20	53.09	330
SCI-CRS-24IL-P	46	20	53.09	330
SCI-CRS-26IL-N	66	20	53.09	396
SCI-CRS-26IL-P	66	20	53.09	396
SCI-CRS-36IL-N	66	20	53.09	448
SCI-CRS-36IL-P	66	20	53.09	448
Back-to-Back				
SCI-CRS-24B2B-N	46	30.5	53.09	330
SCI-CRS-24B2B-P	46	30.5	53.09	330
SCI-CRS-34B2B-N	46	30.5	53.09	404
SCI-CRS-34B2B-P	46	30.5	53.09	404
SCI-CRS-36B2B-N	66	30.5	53.09	447
SCI-CRS-36B2B-P	66	30.5	53.09	447
SCI-CRS-44B2B-N	46	30.5	53.09	481
SCI-CRS-44B2B-P	46	30.5	53.09	481
SCI-CRS-46B2B-N	66	30.5	53.09	519
SCI-CRS-46B2B-P	66	30.5	53.09	519
SCI-CRS-56B2B-N	66	30.5	53.09	597
SCI-CRS-56B2B-P	66	30.5	53.09	597
SCI-CRS-66B2B-N	66	30.5	53.09	674
SCI-CRS-66B2B-P	66	30.5	53.09	674

*For outdoor models, change SCI to SCO

BUILDING MANAGEMENT SYSTEM

BACnet and MODBUS INTERFACE

- Use the ICC Control to enable/disable the water heater
- Change temperature set points and differentials
- Two models with four different configurations to connect to BACnet and Modbus
- Ethernet and Serial RS-485 versions available
- 2 wire or 4 wire RS-485 Network
- Heater connection wiring supplied with unit
- Power can be supplied via the USB cable, as a 7-24 VDC input on the main terminal block, or via IEEE 802.3af power over ethernet (PoE on ETH-1000 only)
- Configure protocols, network characteristics, and client/server object definitions
- Graphically interact with the internal database in real-time via USB connection
- Automatically discover and configure IP settings ethernet gateways connected to the current subnet
- Update firmware

BUILDING MANAGEMENT SYSTEM BACNET AND MODBUS INTERFACE

BMS gateway for control of State Water Heaters

Connect your State Water Heater to your building management system using the new Millennium control from ICC (Industrial Control Communications, Inc.)

- Works with Ultra Force, SUF, SUFL, SHE, SEV/SEH, SSE and CSB-IFE



ETH-1000 Ethernet connection
Mirius Serial Gateway



Kit Part #	Connection Type
100316044	Serial
100316045	Ethernet (IP)

One unit needed per water heater.

ELECTRIC TANKLESS



RESIDENTIAL



COMMERCIAL



DRY-FIRE PROTECTION

- Prevents element failure due to dry fire
- Internal air bypass
- Temporary shutoff with excess air in chamber

WIDE VARIETY OF KW AND VOLTAGE OPTIONS FOR EVERY APPLICATION

- 12.2kW – 32kW
- 208V and 240V options

EASY INSTALL

- Mounts easily to the wall
- No venting required
- ¾" NPT water connections
- No T&P valve required (check local codes)

CONTINUOUS HOT WATER WHEN SIZED APPROPRIATELY

SCALE-REDUCTION TECHNOLOGY

- Reduces failures and service requirements due to hard scale buildup
- Power-sharing technology reduces scale deposits on the element
- Dupont™ Zytel® chambers naturally resist scaling buildup

SOFT START

- Unit will not cause lights to dim with hard electricity draw

CODE COMPLIANCE

- Meets current UBC and CEC National Codes
- Meets or exceeds current federal minimum energy standards, according to the National Appliance Energy Conservation Act (NAECA)
- Listed and tested to UL 499 Appliance and UL 834 Space Heating standards
- Control tested to achieve temperature limit control requirements of UL 353 and CSA C22.2

5-YEAR LIMITED WARRANTY

- For complete information, consult the written warranty or go to statewaterheaters.com

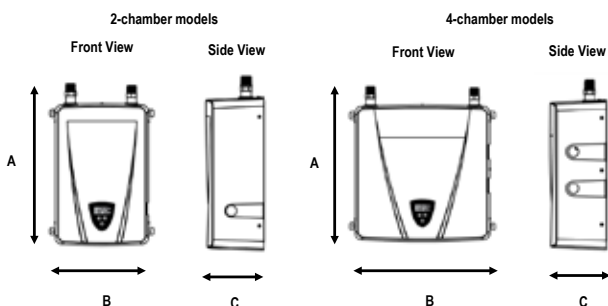

Model Number	Wattage (kW)	Voltage (V)	Amperage (A)	UEF	Dimensions (in)			Approx. Shipping Weight (lbs)
					A	B	C	
Residential 2-Chamber Models								
R2VS-140E	14	240	58	0.84	17-3/4	11-1/2	6-1/8	13
R2VS-140X	14	208	67	0.84	17-3/4	11-1/2	6-1/8	13
R2VS-160E	16	240	67	0.84	17-3/4	11-1/2	6-1/8	13
Residential 4-Chamber Models								
R4LS-180E	18	240	75	0.92	18-1/8	17	6-1/8	20
R4LS-220E	22	240	92	0.92	18-1/8	17	6-1/8	20
R4LS-240E	24	240	100	0.92	18-1/8	17	6-1/8	20
R4LS-280E	28	240	117	0.92	18-1/8	17	6-1/8	20
R4LS-280X	28	208	135	0.92	18-1/8	17	6-1/8	20
R4MS-320E	32	240	133	0.93	18-1/8	17	6-1/8	20

Model Number	Wattage (kW)	Voltage (V)	Amperage (A)	UEF	Dimensions (in)			Approx. Shipping Weight (lbs)
					A	B	C	
Commercial 2-Chamber								
C2VS-120E	12.2	240	51	0.84	17-3/4	11-1/2	6-1/8	13
C2VS-140E	14	240	58	0.84	17-3/4	11-1/2	6-1/8	13
C2VS-140X	14	208	67	0.84	17-3/4	11-1/2	6-1/8	13
C2VS-160E	16	240	67	0.84	17-3/4	11-1/2	6-1/8	13
Commercial 4-Chamber								
C4LS-180E	18	240	75	0.92	18-1/8	17	6-1/8	20
C4LS-220E	22	240	92	0.92	18-1/8	17	6-1/8	20
C4LS-280E	28	240	117	0.92	18-1/8	17	6-1/8	20
C4LS-280X	28	208	135	0.92	18-1/8	17	6-1/8	20
C4MS-320E	32	240	133	0.93	18-1/8	17	6-1/8	20

Dimensions and specifications are subject to change without notice in accordance with our policy of continuous product improvement.

Temperature Range: 90°- 140°F.

Recommended that all wire be rated 90°C or greater.

Factory set point is 120°F. This can easily be changed in the field as needed or desired.

Refer to National Electric Code Article 220 for calculating load contribution.

240V models can run on 208V with 25% reduced power output.

Refer to local code where applicable.

* Maximum recommended wire size is #6 cu AWG.

FORCE® 90 POWER VENT



ENERGY STAR® QUALIFIED CONDENSING DESIGN

- Helical internal heat exchanger achieves 94% thermal efficiency, which saves money on operating costs compared to a standard 80% efficient gas water heater

POWER VENT DESIGN FOR INSTALLATION VERSATILITY

- Combined vertical and horizontal runs terminating through an outside wall, using Schedule 40 PVC or CPVC pipe
 - 2" pipe allows vent runs up to 25 equivalent feet
 - 3" pipe allows vent runs up to 65 equivalent feet
 - 4" pipe allows vent runs up to 128 equivalent feet

HIGH OUTPUT WITH SMALL FOOTPRINT

- 22" diameter, combined with 90% efficiency, 50-gallon tank and 76,000 BTU input means Force® 90 can be installed in less space than a larger 75-gallon unit, with equal or better performance

SIDE-MOUNTED HOT AND COLD RECIRCULATING TAPS

3-YEAR LIMITED TANK AND 1-YEAR LIMITED PARTS WARRANTY

- For complete information, consult written warranty or go to statewaterheaters.com



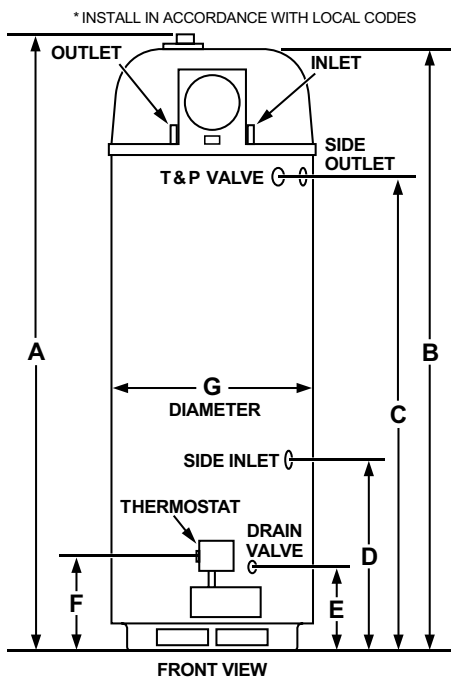
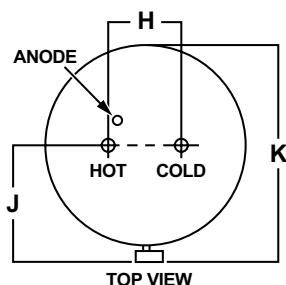

Model Number	Gallon Capacity	Recovery Capacity GPH @ 100°F Rise	BTU Input Per Hour	Approx. Shipping Weight (lbs)
SHE50-76N	50	83	76,000	210

Model Number	Dimensions in Inches									
	A	B	C	D	E	F	G	H	J	K
SHE50-76N	71	68-5/8	52	21	9-1/8	12	22	8	15-3/4	27

Available in natural gas only.

Standard model certified for sea level to 5,300 ft. elevation. Order SHE70-76NED for elevations to 10,100 ft.

Optional Condensate Neutralizer Kit available (Part Number 100112380).

FORCE® 90+ POWER DIRECT VENT



ENERGY STAR® QUALIFIED CONDENSING DESIGN

- Helical internal heat exchanger keeps hot combustion gases in the tank longer to extract more heat into the water
- High efficiency operation with up to 0.88 UEF (96% Thermal Efficiency) which saves money on operating costs compared to a standard efficiency gas water heater

ADVANCED ELECTRONIC CONTROL

- Optional Powered Anode available
- Exclusive State designed touch display control system
- Precise temperature control
- Built-in diagnostics and operational information

POWER DIRECT VENT DESIGN

- Power Direct vent using PVC, CPVC or Polypropylene either thru-the-wall or thru-the-roof
- Optional concentric vent and low profile termination kits are available

ULTRA-LOW NOX

- Complies with SCAQMD Rule 1146.2 and other air quality management districts with similar requirements for Ultra-Low NOx emissions requirements of 14 ng/J or 20 PPM

SIDE-MOUNTED HOT AND COLD RECIRCULATING TAPS

- Hot and cold “side taps” allow Vertex Power Direct Vent to be used for combination space/ water heating applications

CODE COMPLIANCE

- Meets IBC and ICC National Codes
- Meets the thermal efficiency and standby loss requirements of the U. S. Department of Energy and current edition of ASHRAE/IES 90.1

3-YEAR LIMITED TANK AND PARTS WARRANTY

- For complete information, consult written warranty or go to statewaterheaters.com



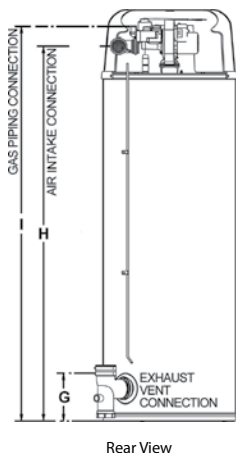
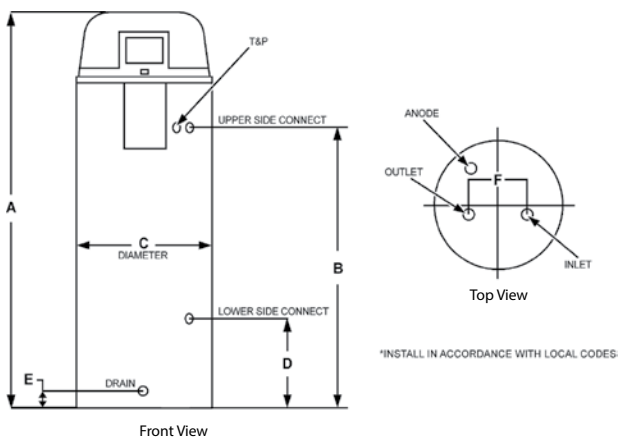

Model Number	Gallon Capacity	Recovery Capacity GPH @ 100°F Rise	BTU Input Per Hour	Approx. Shipping Weight (lbs)
SHE50-100NE	50	116	100,000	255

Model Number	Dimensions in Inches								
	A	B	C	D	E	F	G	H	I
SHE50-100NE	66-3/4	49-1/4	22	15-3/4	3	8	8	62	65

Standard model certified from sea level to 10,100 ft. elevation.

Available with a Powered Anode. Specify when ordering.

Optional Concentric Vent Kits (100111100) and Condensate Neutralization Kits (100112380).

Substitute "P" for "N" in the model number for LP (Propane) gas model.

FORCE® 90+ POWER DIRECT VENT



ENERGY STAR® QUALIFIED CONDENSING DESIGN

- Helical internal heat exchanger keeps hot combustion gases in the tank longer to extract more heat into the water
- High efficiency operation with up to 0.88 UEF (96% Thermal Efficiency) which saves money on operating costs compared to a standard efficiency gas water heater

ADVANCED ELECTRONIC CONTROL

- Optional Powered Anode available
- Exclusive State designed touch display control system
- Precise temperature control
- Built-in diagnostics and operational information

POWER DIRECT VENT DESIGN

- Power Direct vent using PVC, CPVC or Polypropylene either thru-the-wall or thru-the-roof
- Optional concentric vent and low profile termination kits are available

ULTRA-LOW NOX

- Complies with SCAQMD Rule 1146.2 and other air quality management districts with similar requirements for Ultra-Low NOx emissions requirements of 14 ng/J or 20 PPM

SIDE-MOUNTED HOT AND COLD RECIRCULATING TAPS

- Hot and cold “side taps” allow Vertex Power Direct Vent to be used for combination space/ water heating applications

CODE COMPLIANCE

- Meets IBC and ICC National Codes
- Meets the thermal efficiency and standby loss requirements of the U. S. Department of Energy and current edition of ASHRAE/IES 90.1

3-YEAR LIMITED TANK AND PARTS WARRANTY

- For complete information, consult written warranty or go to statewaterheaters.com

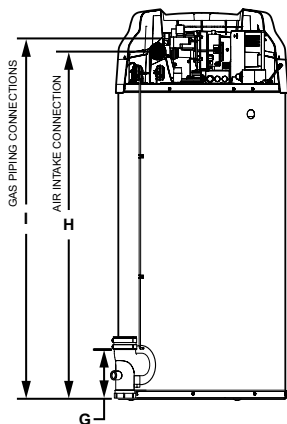
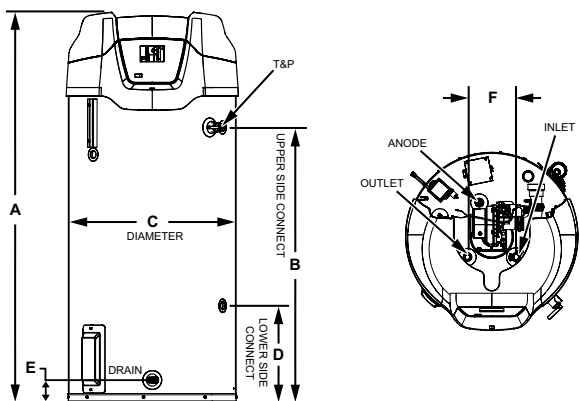

Model Number	Gallon Capacity	Recovery Capacity GPH @ 100°F Rise	BTU Input Per Hour	Approx. Shipping Weight (lbs)
SHE75-100NE	75	116	100,000	382

Model Number	Dimensions in Inches								
	A	B	C	D	E	F	G	H	I
SHE75-100NE	65-1/4	45-5/8	27-3/4	16	3-3/4	8	8	57-1/4	59

Standard model certified from sea level to 10,100 ft. elevation.

Available with a Powered Anode. Specify when ordering.

Optional Concentric Vent Kits (100111100) and Condensate Neutralization Kits (100112380).

Substitute "P" for "N" in the model number for LP (Propane) gas model (example: SHE75-100PE).

MODULATING ULTRA FORCE®



HIGH EFFICIENCY MODULATING PRE-MIX POWERED BURNER

- Down-fired pre-mix burner provides optimum efficiency and quiet operation
- Top-mounted burner position prevents condensation from affecting burner operation

UP TO 98% EFFICIENT

INTELLIGENT CONTROL SYSTEM WITH TOUCH SCREEN DISPLAY

- Exclusive State designed control system
- Provides detailed water heater status information
- Precise temperature control adjustable from 90 to 180
- Built-in diagnostics
- Run history information
- Ultra Force® water heaters include iCOMM remote connectivity. Models 120-250 require optional Wi-Fi communications kit, models 300-500 come standard with Wi-Fi connectivity.

SUBMERGED COMBUSTION CHAMBER, WITH HELICAL HEAT EXCHANGER COIL

- Positioned in center of tank, surrounded by water to virtually eliminate radiant heat loss from chamber
- Direct spark ignition
- Spiral heat exchanger keeps hot burner gases swirling, uses centrifugal force to maximize efficiency of heat transfer to water in tank
- Spiral heat exchanger reduces lime scale from forming on water-side surfaces, which maintains energy efficiency over time

POWERED ANODES STANDARD ON ALL MODELS

- Provides long-lasting tank protection in varying water conditions
- Powered anodes are non-sacrificial
- Automatically adjusts output needed to properly protect the tank

3-YEAR LIMITED TANK AND 1-YEAR LIMITED PARTS WARRANTY

- For complete information, consult written warranty or go to statewaterheaters.com



ASME ANS/NSF-5

Model Number	Approx. Gallon Capacity	Recovery Capacity	Input BTU/Hr	Approx. Shipping Weight Std	Approx. Shipping Weight ASME
SUF60-120NE(A)	60	138	120,000	460	490
SUF100-150NE(A)	100	178	150,000	523	553
SUF100-199NE(A)	100	235	199,900	523	553
SUF100-250NE(A)	100	291	250,000	523	553
SUF119-300NE(A)	119	349	300,000	855	855
SUF119-400NE(A)	119	460	399,900	855	855
SUF119-500NE(A)	119	576	499,900	855	855

Electrical characteristics - 120V - 60Hz A.C., 5.0A

Change "N" to "P" in model number for propane. "A" in model represents ASME construction.

Concentric Vent Kit 100111100 for SUF60-120 through SUF 100-250 Models

Concentric Vent Kit 100113124 for SUF130-300 & SUF130-500 Models.

Dimensions and Line Drawings on the following pages.

MODULATING ULTRA FORCE®

(CONTINUED)

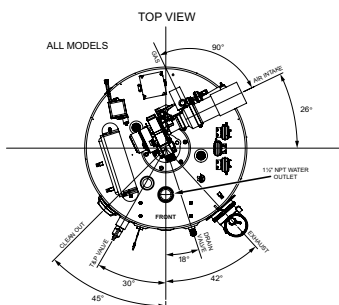

* Center line of water outlet on top of the water heaters is approximately 7 inches from the front edge of the water heater.

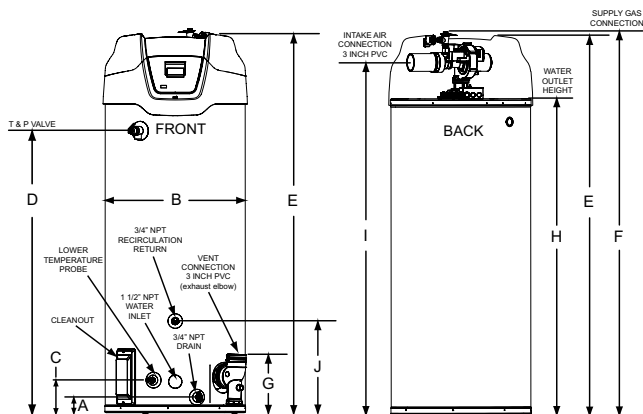

Model Number	Dimensions in Inches									
	A	B	C	D	E	F	G	H	I	J
SUF60-120NE(A)	3	27.75	6.3	35	53.5	55.5	11.25	42.25	48.5	18.25
SUF100-150-NE(A)	3	27.75	6.3	56.38	75.75	76	11.25	64	70	18.25
SUF100-199NE(A)	3	27.75	6.3	56.38	75.75	76	11.25	64	70	18.25
SUF100-250NE(A)	3	27.75	6.3	56.38	75.75	76	11.25	64	70	18.25

Electrical characteristics - 120V - 60Hz A.C., 5.0A

Change "N" to "P" in model number for propane (Example: SUF119 300PE).

"A" in model represents ASME construction.

Concentric Vent Kit 100111100 for SUF60-120 through SUF100-250 Models

Concentric Vent Kit 100113124 for SUF119-300 & SUF119-500 Models.

Models are certified from sea level to 10,100 ft. elevation.

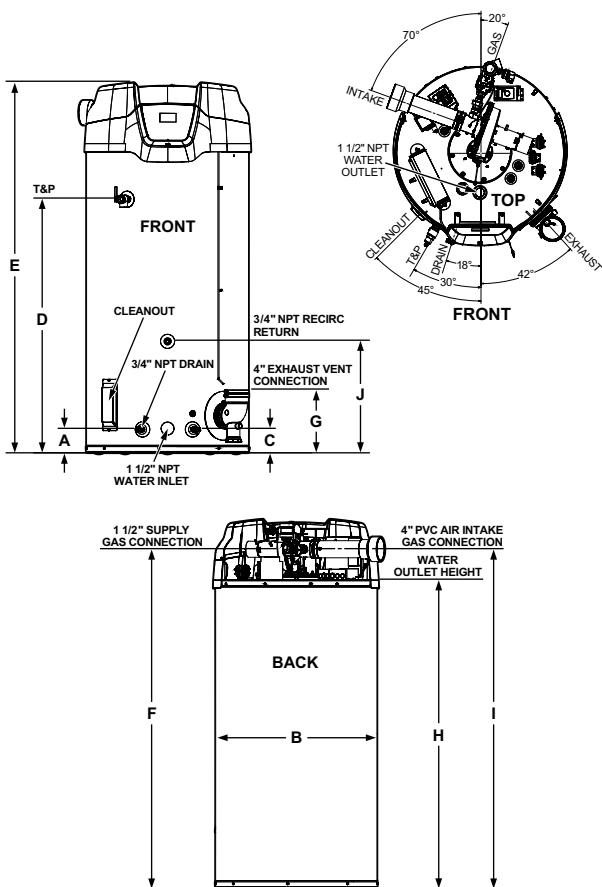

Model Number	Dimensions in Inches									
	A	B	C	D	E	F	G	H	I	J
SUF119-300NE(A)	4.75	33.12	4.75	52	75.75	73.75	12.75	63.13	69.25	23
SUF119-400NE(A)	4.75	33.12	4.75	52	75.75	73.75	12.75	63.13	69.25	23
SUF119-500NE(A)	4.75	33.12	4.75	52	75.75	73.75	12.75	63.13	69.25	23

Electrical characteristics - 120V - 60Hz A.C., 5.0A

Change "N" to "P" in model number for propane (Example: SUF119-300PE).

"A" in model represents ASME construction.

Concentric Vent Kit 100111100 for SUF60-120 through SUF100-250 Models

Concentric Vent Kit 100113124 for SUF119-300 & SUF119-500 Models.

Models are certified from sea level to 10,100 ft. elevation.

ULTRA FORCE™ XL



EXTENDS ULTRA FORCE CONDENSING PRODUCTS TO 1,000,000 BTU/H

- High efficiency, condensing water heaters with modulating burner to 1,000,000 Btu/h
- Primary and secondary heat exchangers keep hot combustion gases in the tank longer to extract more heat into the water
- Models from 750,000 to 1,000,000 Btu/h deliver thermal efficiencies of 97%, saving money on operating costs
- PermaGlas® glass-lining provides superior protection against corrosion for the ASME-certified tank and primary heat exchanger

ELECTRONIC CONTROL & DISPLAY

- iCOMM™ connectivity platform provides diagnostic and operational information
- Integrated color touch display/control system is standard on all models
- Precise temperature control, adjustable from 90° F. to 180° F
- Remote monitoring, diagnostic fault notifications, and control of the set point and differential via the free State mobile app

PRIMARY AND SECONDARY HEAT EXCHANGERS

- Glass-lined 304L stainless steel primary HX positioned in center of tank, surrounded by water, to virtually eliminate radiant heat loss from chamber
- Secondary HX (where condensing process occurs) constructed of type 316L stainless steel for additional corrosion resistance
- 2-step heat transfer process between primary and secondary HX maximizes heat transfer, creating thermal efficiency of 97%

POWER ANODES STANDARD ON ALL MODELS

- Provides long-lasting tank protection in varying water conditions
- Non-sacrificial powered anodes prevent lime scale from forming on water-side surfaces, which maintains energy efficiency over time
- Automatically adjusts output needed to properly protect the tank

5-YEAR LIMITED TANK AND 1-YEAR LIMITED PARTS WARRANTY

- For complete information, consult written warranty or go to statewaterheaters.com

Model Number	Gallon Capacity	Recovery Capacity	Input BTU/HR	Approx. Shipping Weight (lbs) ASME
SUS-120-750A	120	882	750,000	1,300
SUS-120-1000A	120	1,176	1,000,000	1,300

Electrical characteristics - 120V-60 Hz A.C., 5.0A

"A" in model number represents ASME construction.

Models are certified from sea level to 10,100 ft. elevation.

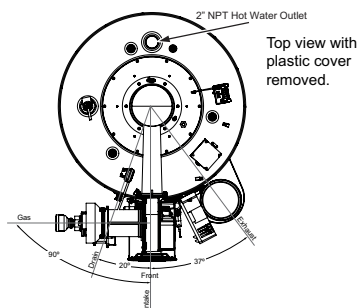
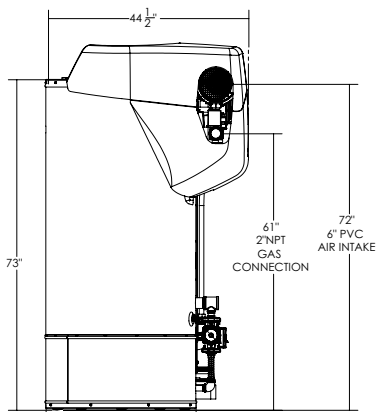
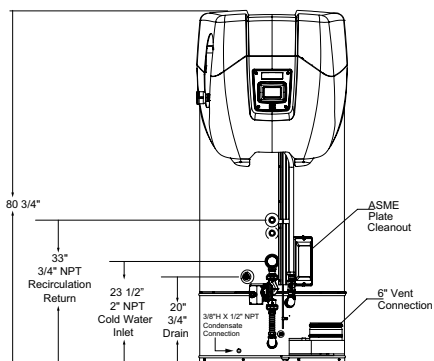

MODULATING ULTRA FORCE™ LV



LARGE VOLUME TANK + CONDENSING DESIGN

- Large volume, integrated storage capacity to 250-gallons eliminates need for multiple water heaters or separate storage tank, saving space and install cost
- Helical internal heat exchanger keeps hot combustion gases in the tank longer to extract more heat into the water
- Models from 150,000 to 500,000 Btu/h deliver thermal efficiencies to 96%, saving money on operating costs
- PermaGlas® glass-lining process provides superior protection against corrosion for the large volume, ASME-certified storage tank

ELECTRONIC CONTROL & DISPLAY

- iCOMM™ connectivity platform provides diagnostic and operational information
- Integrated color touch display/control system is standard on all models
- Precise temperature control, adjustable from 90° F. to 180° F
- Remote monitoring, diagnostic fault notifications, and control of the set point and differential via the free State mobile app

SUBMERGED COMBUSTION CHAMBER WITH HELICAL HEAT EXCHANGER COIL

- Positioned in center of tank, surrounded by water to virtually eliminate radiant heat loss from chamber
- Direct spark ignition
- Spiral heat exchanger keeps hot burner gases swirling, uses centrifugal force to maximize efficiency of heat transfer to water in tank
- Spiral heat exchanger reduces lime scale from forming on water-side surfaces, which maintains energy efficiency over time

POWER ANODES STANDARD ON ALL MODELS

- Provides long-lasting tank protection in varying water conditions
- Powered anodes are non-sacrificial
- Automatically adjusts output needed to properly protect the tank

5-YEAR LIMITED TANK AND 1-YEAR LIMITED PARTS WARRANTY

- For complete information, consult written warranty or go to statewaterheaters.com



ASME

(All models except SUFL-220-500A)





Model Number	Gallon Capacity	Recovery Capacity	Input BTU/HR	Approx. Shipping Weight (lbs) ASME
SUFL-250-150A	250	175	150,000	1125
SUFL-250-199A	250	230	199,900	1125
SUFL-250-250A	250	285	250,000	1125
SUFL-220-300A	220	342	300,000	1420
SUFL-220-400A	220	451	399,900	1420
SUFL-220-500A	220	557	499,900	1420

"A" in model number represents ASME construction.

Models are certified from sea level to 10,100 ft. elevation.

MODULATING ULTRA FORCE™ LV

(CONTINUED)

SUFL-250-150A — SUFL-250-250A

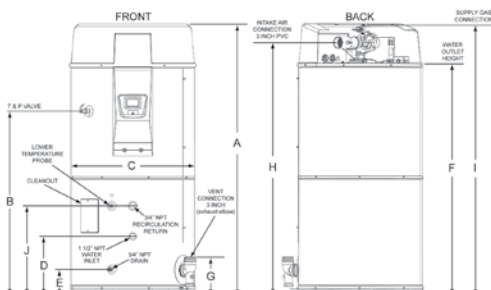

These designs comply with the current edition of the American National Standard for Gas Water Heaters, Volume III, ANSI Z21.10.3 / CSA 4.3 as an automatic circulating tank water heater, and automatic storage water heaters.

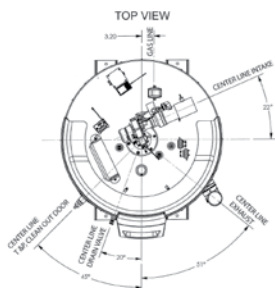

* Center line of water outlet on top of the water heaters is approximately 13 inches from the front edge of the water heater.

Figure 5. Rough-In Dimensions

Model Number	Dimensions				
	A	B	C	D	E
SUFL-250-150A	91-1/2	62-5/8	42-1/8	20-1/2	8-1/2
SUFL-250-199A	91-1/2	62-5/8	42-1/8	20-1/2	8-1/2
SUFL-250-250A	91-1/2	62-5/8	42-1/8	20-1/2	8-1/2

Model Number	Dimensions				
	F	G	H	I	J
SUFL-250-150A	78-1/8	12	85	90-1/8	30-1/2
SUFL-250-199A	78-1/8	12	85	90-1/8	30-1/2
SUFL-250-250A	78-1/8	12	85	90-1/8	30-1/2

Optional Concentric Vent Kits available. 100111100 (SUFL-250-150A through SUFL-250-250A models).

Optional Condensate Neutralization Kits available. 100112380 (SUFL-250-150A through SUFL-250-199A models), 100112381 (SUFL-250-250A through SUFL-220-500A models).

Electrical characteristics - 120V-60 Hz A.C., 5.0A

"A" in model number represents ASME construction.

Models are certified from sea level to 10,100 ft. elevation.

SUFL-220-300A — SUFL-220-500A

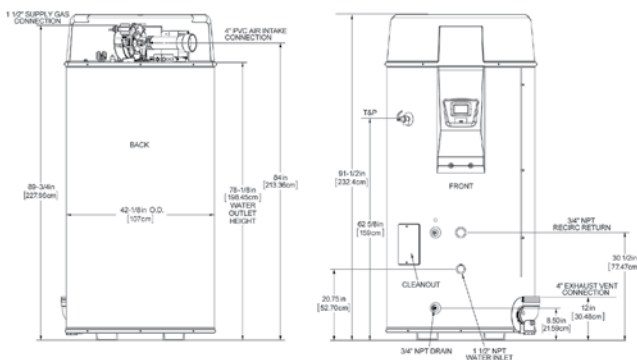

TOP VIEW

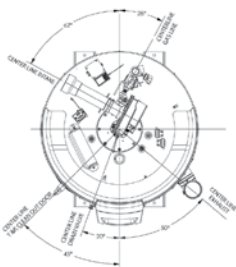

Model Number	Dimensions				
	A	B	C	D	E
SUFL-220-300A	91-1/2	62-5/8	42-1/8	20-3/4	8-1/2
SUFL-220-400A	91-1/2	62-5/8	42-1/8	20-3/4	8-1/2
SUFL-220-500A	91-1/2	62-5/8	42-1/8	20-3/4	8-1/2

Model Number	Dimensions				
	F	G	H	I	J
SUFL-220-300A	78-1/8	12	84	89-3/4	30-1/2
SUFL-220-400A	78-1/8	12	84	89-3/4	30-1/2
SUFL-220-500A	78-1/8	12	84	89-3/4	30-1/2

Optional Concentric Vent Kits available. 100113124 (SUFL-220-300A through SUFL-220-500A models).

Optional Condensate Neutralization Kits available. 100112381 (SUFL-250-150A through SUFL-220-500A models).

Electrical characteristics - 120V-60 Hz A.C., 5.0A

"A" in model number represents ASME construction.

Models are certified from sea level to 10,100 ft. elevation.

POLARIS™ HIGH EFFICIENCY



CONDENSING DESIGN

- Operates at up to 96% thermal efficiency which saves money on operating costs compared to a standard 80% efficient gas water heater
- Helical internal heat exchanger keeps hot combustion gases in the tank longer to extract more heat into the water

STAINLESS STEEL CONSTRUCTION

- Tank and helical heat exchanger are constructed from 444 stainless steel for excellent corrosion resistance without the need for an anode

WHISPER QUIET OPERATION

- Ultra-quiet blower and burner minimize noise

POWER DIRECT VENT DESIGN

- Direct vent using PVC, CPVC or ABS either thru-the-wall or thru-the-roof

OPTIONAL CONCENTRIC VENT KIT

ADVANCED ELECTRONIC CONTROL

- Large LCD display provides precise temperature control and advanced diagnostics

CODE COMPLIANCE

- Complies with SCAQMD Rule 1146.2 and other air quality management districts with similar requirements for Ultra-Low NOx emissions requirements of 14 ng/J or 20 PPM
- Meets UBC, CEC, and ICC National Codes
- Meets the thermal efficiency and standby loss requirements of the U. S. Department of Energy and current edition of ASHRAE/IES 90.1

3-YEAR LIMITED TANK AND 1-YEAR LIMITED PARTS WARRANTY

- For complete information, consult written warranty or go to statewaterheaters.com



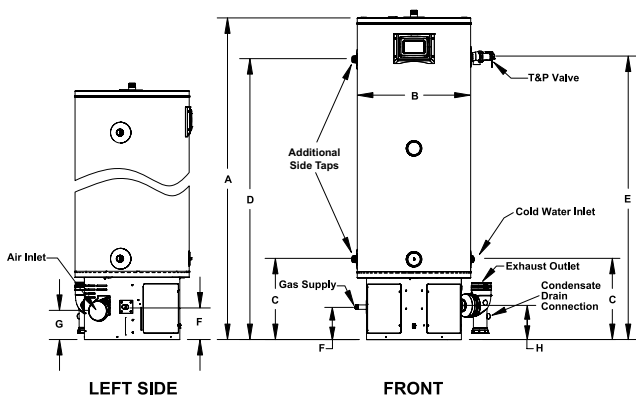
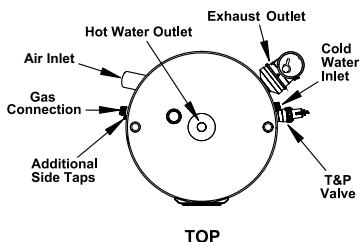

Model Number	Gallon Capacity	BTU/h Input Gallon Per Hour	Thermal Efficiency	Recovery Capacity GPH @ 100°F Rise	Approx. Shipping Weight (lbs)
SPC-34-130-NE	34	130,000	96%	149	150
SPC-34-150-NE	34	150,000	94%	171	150
SPC-50-130-NE	50	130,000	95%	149	176
SPC-50-150-NE	50	150,000	95%	171	180
SPC-50-175-NE	50	175,000	96%	200	180
SPC-50-199-NE	50	199,000	96%	227	180

Model Number	Dimensions in Inches		Vent Connection	1" Water Connections		T&P	Gas Supply*
	A	B		C	D		
SPC-34-130-NE	48-1/2	22	2 or 3	15-3/4	40-1/2	41	6-3/8
SPC-34-150-NE	48-1/2	22	2 or 3	15-3/4	40-1/2	41	6-3/8
SPC-50-130-NE	62-3/8	22	2 or 3	15-3/4	54-1/2	55	6-3/8
SPC-50-150-NE	63-3/4	22	2 or 3	15-3/4	55-3/4	56-1/4	6-3/8
SPC-50-175-NE	63-3/4	22	3	15-3/4	55-3/4	56-1/4	6-3/8
SPC-50-199-NE	63-3/4	22	3	15-3/4	55-3/4	56-1/4	6-3/8

For Propane (LP) gas change "NE" to "PE"
Models certified for sea level to 7,700 ft. elevation.

TX1 INTEGRATED TANKLESS ON TANK



DELIVERS 96% THERMAL EFFICIENCY ULTRA-LOW NOX OPERATION

- Complies with SCAQMD Rule 1146.2 and other Air Quality Management Districts with similar requirements for ultra low-NOx emissions

USES CT-199 COMMERCIAL TANKLESS

- Modulating burner
- Primary heat exchanger constructed of commercial grade copper
- Secondary heat exchanger constructed of 316 grade stainless steel
- Advanced electronic control with integrated diagnostics
- 185°F maximum temperature

119 GALLON STORAGE TANK

- 4.1 GPM pump
- Glass lined tank
- Multiple anodes to protect the tank
- Front water inlet and top water outlet

6 YEAR LIMITED HEAT EXCHANGER AND TANK, 5 YEAR LIMITED PARTS WARRANTY

- For complete warranty information, consult written warranty or go to statewaterheaters.com



ANSI/NSF 5



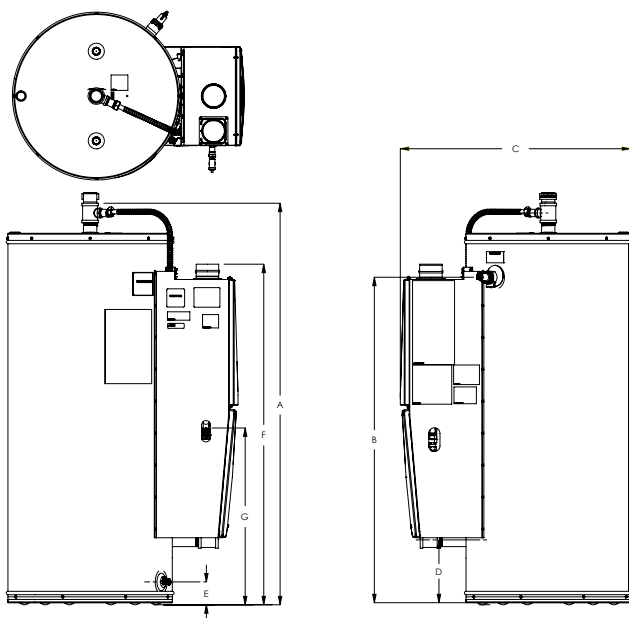

Model Number	Gallon Capacity	Input BTU/ HR	Thermal Efficiency %	Recovery @ 100° Rise GPH	Approx. Shipping Weight (lbs.)
STX-199	119	199,000	96	232	520

Model Number	Dimensions						
	A	B	C	D	E	F	G
STX-199	72	58-11/16	41	11-13/16	4-5/16	61-3/8	30

Electrical characteristics-120V-60Hz A.C., 5.0 A

Propane gas models available

Dimensions and specifications subject to change without notice in accordance with our policy of continuous product improvement

SANDBLASTER®

SELF-CLEANING - SBD SERIES



SELF-CLEANING HYDRO CANNON™

- Significantly reduces sediment buildup inside the tank
- Maintains rated thermal efficiency, reduces water heating costs
- Maximizes tank life

AUTOMATIC FLUE DAMPER (120–390 MODELS)

- Automatic motorized flue damper helps minimize standby heat loss
- Low-profile draft diverter helps for installation in tight spaces
- SBD85 500 Model features induced draft design and no damper

THREE WATER CONNECTION OPTIONS

- Hot and cold water connections can be made through front, top or rear of unit
- Hydro Cannon™ operates when cold water is connected through front

INTERMITTENT ELECTRONIC IGNITION

- Eliminates standing pilot, saves energy
- Includes power ON/OFF switch
- Provides flame failure response in less than one second

3-YEAR LIMITED AND 1-YEAR LIMITED TANK WARRANTY

- For complete warranty information, consult written warranty or go to statewaterheaters.com



Model Number	Gallon Capacity	Input BTU/HR	100°F Rise Recovery G.P.H.	Approx. Shipping Weight (lbs)
FLUE DAMPER MODELS				
SBD71-120NE†	71	120,000	116	400
SBD81-154NE	81	154,000	149	470
SBD81-180NE	81	180,000	175	470
SBD100-199NET	100	199,000	193	603
SBD100-199NE	100	199,000	193	603
SBD81-199NE	81	199,000	193	470
SBD100-199NES	100	199,000	193	630
SBD100-250NE*	100	250,000	242	630
SBD65-251NE*	65	251,000	243	750
SBD100-275NE*	100	275,000	267	630
SBD65-305NE	65	305,000	296	750
SBD85-365NE	85	365,000	354	725
SBD100-390NE	100	390,000	378	760
SBD85-500NE***	85	500,000	485	812
ASME MODELS - ASME Models are design certified for a maximum allowable working pressure of 160 PSI				
SBD100-199NE-A	100	199,000	193	724
SBD100-250NE-A*	100	250,000	242	725
SBD65-251NE-A*	65	251,000	243	862
SBD100-275NE-A*	100	275,000	267	725
SBD65-305NE-A	65	305,000	296	862
SBD85-365NE-A	85	365,000	354	833
SBD100-390NE-A	100	390,000	378	874
SBD85-500NE-A***	85	500,000	485	857

Model SBD71-120NE is shipped with 6" x 5" flue outlet adapter.

**Models certified for either 6" or 8" venting, see local codes.

***Induced draft design, Category I Venting

Substitute "P" for "N" in model number for LP (Propane) gas models (Example: SBD100-199PE).

Dimensions and Line Drawings on the following pages.

SANDBLASTER®

SELF-CLEANING - SBD SERIES (CONTINUED)

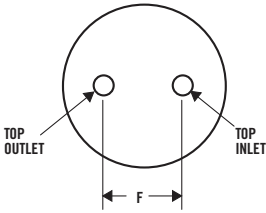

Models SBD 120-390

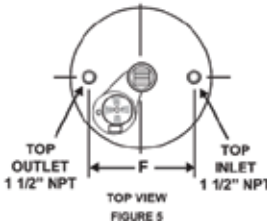
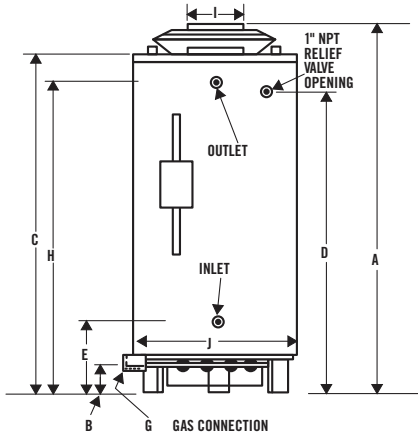

Model SBD 500

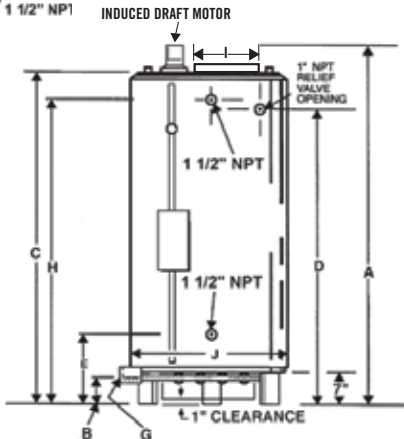

Model Number	Dimensions in Inches					
	A	B	C	D	E	F
SBD71-120NE†	69-3/4	4-1/4	59-1/2	50-7/8	19-11/16	19
SBD81-154NE	67-1/2	4-1/2	62	53-1/2	20-1/2	21
SBD81-180NE	67-1/2	4-1/2	62	53-1/2	20-1/2	21
SBD81-199NE	67-1/2	4-1/2	62	53-5/8	20-1/2	21
SBD100-199NET	75	4-1/2	70	61-5/8	20-1/2	21
SBD100-199NE	75	4-1/2	70	61-5/8	20-1/2	21
SBD100-199NES-(A)	67-1/2	4-1/2	62	53-5/8	20-1/2	21
SBD100-250NE-(A)*	72	4-1/2	65-1/8	55-7/8	19-3/4	23
SBD65-251NE-(A)*	72	4-1/2	65-1/8	55-7/8	19-3/4	23
SBD100-275NE-(A)*	72	4-1/2	65-1/8	55-7/8	19-3/4	23
SBD65-305NE-(A)	75	4-1/2	65-3/4	57-1/4	20	N/A
SBD85-365NE-(A)	79-1/2	4-1/2	70-1/4	62-1/2	22-1/2	23
SBD100-390NE-(A)	75-1/2	4-1/2	67-1/2	58-1/4	26-3/4	23
SBD85-500NE-(A)***	81-1/2	17-1/2	77-1/4	67-1/2	27	21

Model Number	Dimensions in Inches			
	G	H	I	J
SBD71-120NE†	1/2	51-7/8	6	27-3/4
SBD81-154NE	1/2	54-5/8	6	27-3/4
SBD81-180NE	1/2	54-5/8	6	27-3/4
SBD81-199NE	1/2	54-5/8	6	27-3/4
SBD100-199NET	1/2	62-5/8	6	27-3/4
SBD100-199NE	1/2	61-1/2	6	27-3/4
SBD100-199NES-(A)	1/2	54-5/8	6	27-3/4
SBD100-250NE-(A)*	1/2	56-3/8	8	30-1/4
SBD65-251NE-(A)*	1/2	56-3/8	8	30-1/4
SBD100-275NE-(A)*	1/2	56-3/8	8	30-1/4
SBD65-305NE-(A)	1/2	58-3/4	8	27-3/4
SBD85-365NE-(A)	3/4	63	8	27-3/4
SBD100-390NE-(A)	3/4	59	8	30-1/4
SBD85-500NE-(A)***	1	67-1/2	8	27-3/4

SANDBLASTER® ULTRA-LOW NO_x



80% THERMAL EFFICIENCY MEANS LOWER OPERATING COSTS

FAN ASSISTED COMBUSTION

- The blower is built into the low NO_x burner assembly
- Complies with California SCAQMD Rule 1146.2 and other Air Quality Management Districts with similar NO_x emission requirements of 14 ng/J or 20 ppm

AIR-FLAPPER

- A stainless steel air flapper is used inside the premix system to replace externally mounted flue damper to minimize the standby heat loss and to minimize the overall heater height

METAL VENTING

- Rated Category I Appliance. Uses standard double wall type "B" vent.
- Can be commonly vented with other Category I appliances
- Vent connects directly to the vent connector outlet
- An excellent choice for retrofit and upgrade installations

3-YEAR LIMITED TANK AND 1-YEAR LIMITED PARTS WARRANTY

- For complete warranty information, consult written warranty or go to statewaterheaters.com

GAS-FIRED



LISTED



Low Lead Content



AHRI CERTIFIED
www.ahridirectory.org



Model Number	Gallon Capacity	Input BTU/HR	Recovery Capacity GPH @ 100°F Rise
SBL81-120NE	81	120,000	115
SBL81-154NE	81	154,000	148
SBL81-180NE	81	180,000	173
SBL81-199NE	81	199,000	191
SBL100-199NE	100	199,000	191
SBL100-250NE	100	250,000	240
SBL100-275NE	100	275,000	264
SBL86-310NE	86	310,000	298
SBL86-366NE	86	366,000	352
SBL86-390NE	86	390,000	375
SBL100-250NEA	100	250,000	240
SBL100-275NEA	100	275,000	264
SBL86-310NEA	86	310,000	298
SBL86-366NEA	86	366,000	352
SBL86-390NEA	86	390,000	375

Electrical characteristics-120V-60 Hz A. C., 5.0A.

"A" after the model number designates ASME construction.

Leg kits for UL sanitation to meet NSF-5 (increase overall height by 4").

SBL models not available in LP gas.

Dimensions and line drawings on the following pages.

SANDBLASTER® ULTRA-LOW NO_x

(CONTINUED)

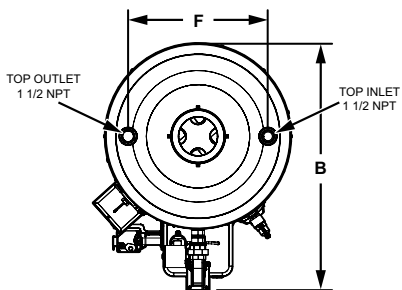

TOP VIEW

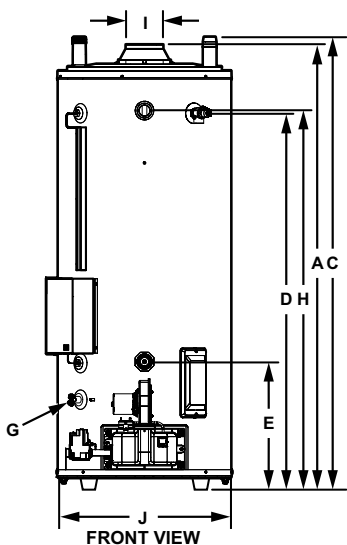

FRONT VIEW

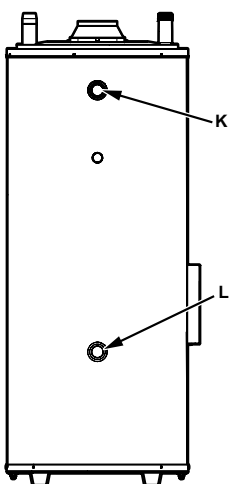

BACK VIEW

Model Dimension	SBL81 120, 154, 180, 198	SBL100 199, 250(A), 275(A)	SBL86 310(A), 366(A), 400(A)
	Dimensions in Inches		
A	63-3/4	71-3/4	71-3/4
B	37	37	37
C	65	73	73
D	52-3/4	60-3/4	60-3/4
E	20-3/4	20-1/2	20-1/2
F	21	21	21
G	3/4 NPT		
H	53	61	61
I	6	6-8	6-8
J	27-3/4	27-3/4	27-3/4
K	1-1/2 NPT		
L	1-1/2 NPT		
Approx. Shipping Weight (lbs)	SBL81 120, 154, 180, 198	SBL100 199, 250(A), 275(A)	SBL86 310(A), 366(A), 400(A)
Standard	650	750	810
ASME	N/A	800	860

Electrical characteristics-120V-60 Hz A. C., 5.0A.

"A" after the model number designates ASME construction.

Leg kits for UL sanitation to meet NSF-5 (increase overall height by 4").

SBL models not available in LP gas.

SANDBLASTER® SBS



Low Lead Content

GAS-FIRED



LISTED

AHR CERTIFIED®
www.ahridirectory.org

CODE COMPLIANCE

- Commercial gas water heater meets the thermal efficiency and standby loss requirements of the U.S. Department of Energy and Current Edition ASHRAE/IES 90.1

FULLY AUTOMATIC CONTROLS WITH SAFETY SHUTOFF

- Accurate, dependable control system requires no electric connections. Fixed automatic gas shutoff device for added safety. Not recommended for 180°F sanitizing.

HEAVY GAUGE STEEL JACKET

- Finished with baked enamel over bonderized undercoat

FOAM INSULATION

- Saves fuel, helps reduce standby heat loss

LOW NO_x EMISSIONS

- Complies with Texas and other districts requirements for NO_x emissions less than ng/J

EASY-TO-INSTALL

- Completely factory-assembled. Only gas, water and vent connections need to be made. All connections are located in front and top of heaters for ease-of-installation and service.

3-YEAR LIMITED TANK AND 1-YEAR LIMITED PARTS WARRANTY

- For complete warranty information, consult written warranty or go to statewaterheaters.com

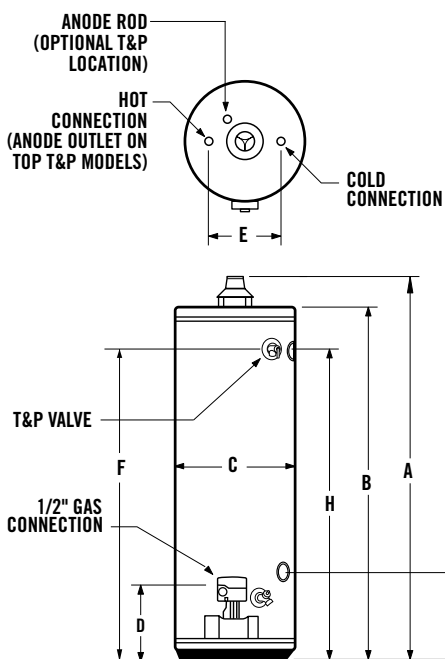

Maximum Hydrostatic Working Pressure: 150 PSI

Gas Type	Capacity		Input Rating		Temperature Rise GPH (LPH)					
	Gallon	Litres	BTU/HR	kW/Hr.	30°F (17°C)	40°F (22°C)	50°F (28°C)	60°F (33°C)	70°F (39°C)	80°F (45°C)
Natural Gas	55	208	60,000	17.6	194 (734)	145 (551)	116 (440)	97 (367)	83 (315)	73 (275)
Propane (LP)	55	208	54,000	15.8	175 (661)	131 (496)	105 (396)	87 (330)	75 (283)	65 (248)

Gas Type	Capacity		Input Rating		Temperature Rise GPH (LPH)					
	Gallon	Litres	BTU/HR	kW/Hr.	90°F (50°C)	100°F (56°C)	110°F (61°C)	120°F (67°C)	130°F (72°C)	140°F (78°C)
Natural Gas	55	208	60,000	17.6	65 (245)	58 (220)	53 (200)	48 (184)	45 (169)	42 (157)
Propane (LP)	55	208	54,000	15.8	58 (220)	52 (198)	48 (180)	44 (165)	40 (152)	37 (142)

Model Number	Gallon Capacity	First Hour Rating Gallon	Energy Factor	Recovery Eff.	BTU Input Natural Gas	BTU Input Propane Gas	GPH Recovery @ 100°F Rise Natural
SBS55-60	55	106	0.59	0.80	60,000	54,000	58

Model Number	GPH Recovery @ 100°F Rise LP	Dimensions in Inches							Approx. Shipping Weight (lbs)
		A	B	C	D	E	F	Draft Hood	
SBS55-60	52	59-3/4	55-1/4	24	13-1/2	8	48	4	185

SANDBLASTER® LIGHT-DUTY



GLASSLINED TANK

- Maximizes tank life
- Fully Automatic Controls with Safety Shutoff
- Accurate, dependable control system requires no electric connections. Fixed automatic gas shutoff device for added safety. Not recommended for 180°F sanitizing.

HEAVY GAUGE STEEL JACKET

- Finished with baked enamel over bonderized undercoat

FOAM INSULATION

- Saves fuel, helps reduce standby heat loss

LOW NO_x

- Complies with Texas and other Districts Requirements for NO_x Emissions Less than 40 ng/J

EASY-TO-INSTALL

- Completely factory-assembled. Only gas, water and vent connections need be made. All connections are located in front and top of heaters for ease of installation and service.

3-YEAR LIMITED TANK/1-YEAR LIMITED PARTS WARRANTY

- For complete warranty information, consult written warranty or go to statewaterheaters.com



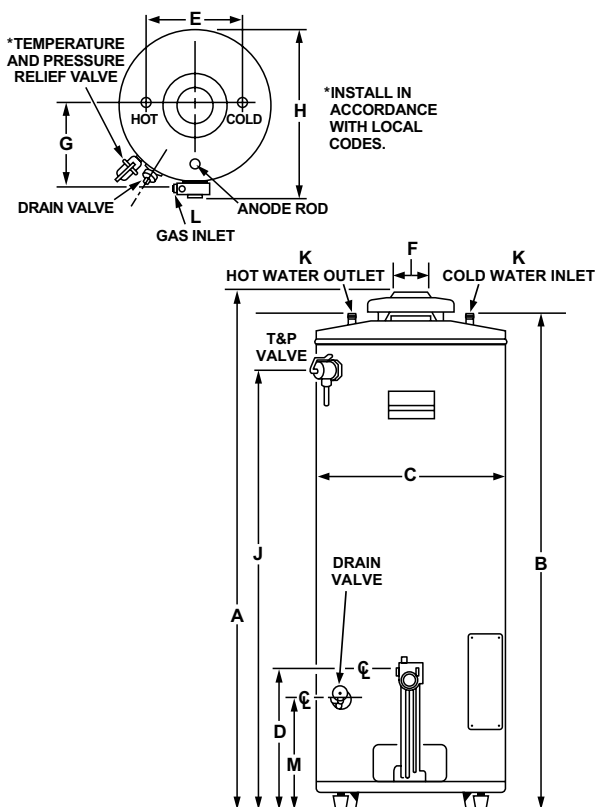

Model Number	Gallon Capacity	Input BTU/HR	Recovery Capacity GPH @ 100°F Rise	Approx. Shipping Weight (lbs)
LIGHT DUTY				
SBS75-76NE	74	75,100	73	275
SBS100-76NE	98	75,100	73	350

Model Number	Dimensions in Inches					
	A	B	C	D	E	F
SBS75-76NE	61-1/8	58-1/2	26-1/2	15-3/16	16	4
SBS100-76NE	68-5/8	66-1/2	27-3/4	15-3/16	16	4

Model Number	Dimensions in Inches					
	G	H	J	K	L	M
SBS75-76NE	14-1/2	29-11/16	54-1/4	1	1/2	11-15/16
SBS100-76NE	15-3/4	30-15/16	54-1/4	1	1/2	11-15/16

NSF leg kit 100111360.

Specify when ordering (LP) gas.

FORCE® POWER DIRECT VENT



SELF-CLEANING DIP TUBE

- Helps reduce lime and sediment buildup and maximizes hot water output. Made from long-lasting PEX cross-linked polymer

BLUE DIAMOND® GLASS COATING

- Provides superior corrosion resistance compared to the industry-standard glasslining

HOT SURFACE IGNITION

- Has a solid state hot surface ignition that does not flutter or blow out
- Eliminates the pilot and saves energy

STANDARDS

- Design-certified by CSA International, according to ANSI Z21.10.3-CSA 4.3 standards governing storage-type water heaters
- Meets the thermal efficiency and standby loss requirements of the U.S. Department of Energy and current edition of ASHRAE/IES 90.1

3-YEAR LIMITED TANK AND 1-YEAR LIMITED PARTS WARRANTY

- For complete warranty information, consult written warranty or go to statewaterheaters.com



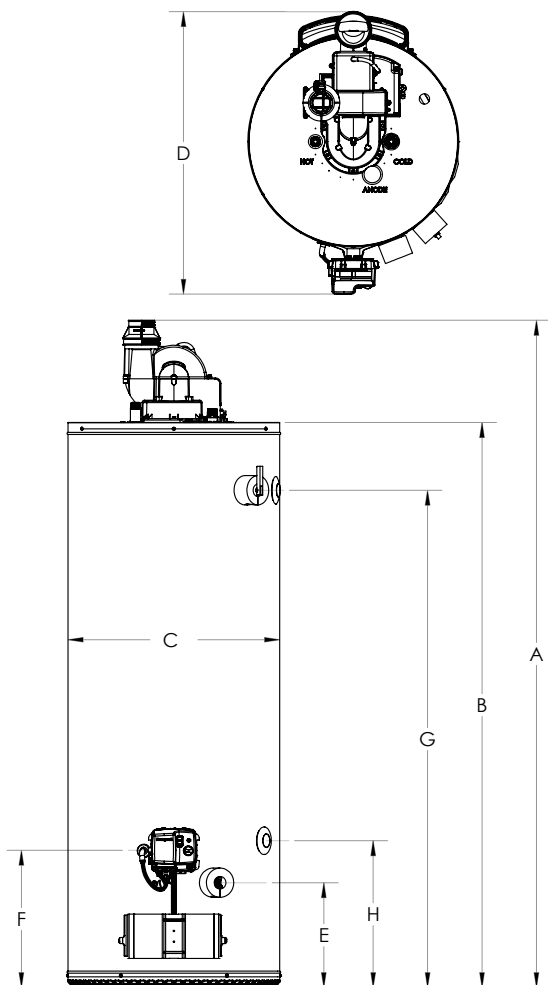

Model Number	Btuh Input	Approx. Capacity	Approx. Shipping Weight (lbs)
SDV75-76NE	76,000	75	277

Model Number	Dimensions in Inches							
	A	B	C	D	E	F	G	H
SDV75-76NE	70-5/8	61-1/4	26	33-1/8	11	13-1/4	53	15-1/4

Can be installed up to 10,100 feet without alteration.
 Specify when ordering propane (LP) gas.
 Recovery capacity based on 81% thermal efficiency.

SANDBLASTER® LOW NO_x SINGLE FLUE



CODE COMPLIANCE

- The Ultra-Low NO_x atmospheric vent commercial gas water heater which meets the thermal efficiency and standby loss requirements of the U.S. Department of Energy and Current Edition ASHRAE/IES 90.1

FULLY AUTOMATIC CONTROLS WITH SAFETY SHUTOFF

- Accurate, dependable control system requires no electric connections. Fixed automatic gas shutoff device for added safety. Not recommended for 180°F sanitizing.

HEAVY GAUGE STEEL JACKET

- Finished with baked enamel over bonderized undercoat

FOAM INSULATION

- Saves fuel, helps reduce standby heat loss

ULTRA-LOW NO_x EMISSIONS

- Complies with SCAQMD Rule 1146.2 and other Air Quality Management Districts with similar requirements of 14 ng/J or 20 ppm

EASY-TO-INSTALL

- Completely factory-assembled. Only gas, water and vent connections need to be made. All connections are located in front and top of heaters for ease-of-installation and service.

3-YEAR LIMITED TANK AND 1-YEAR LIMITED PARTS WARRANTY

- For complete warranty information, consult written warranty or go to statewaterheaters.com

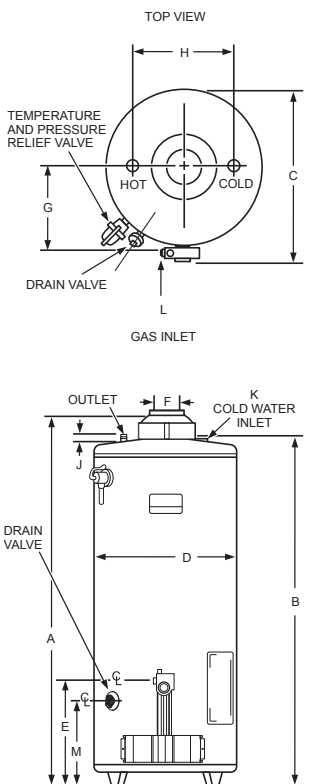

Model Number	Gallon Capacity	Input BTU/HR	Recovery Capacity GPH @ 100° Rise	Approx. Shipping Weight (lbs)
SBL75-76NE**	74	75,100 BTU/h	73	285
SBL100-76NE*	98	75,100 BTU/h	74	350

Model Number	Dimensions in Inches					
	A	B	C	D	E	F
SBL75-76NE	62-1/16	58	29-1/2	25-1/4	15-7/8	4
SBL100-76NE	70-1/2	66-1/2	30-15/16	27-3/4	15-3/16	4

Model Number	Dimensions in Inches					
	G	H	J	K	L	M
SBL75-76NE	15-1/4	16	2	1	1/2	12-1/2
SBL100-76NE	15-3/4	16	1-1/4	1-1/4	1/2	11-15/16

Available in natural gas only.

*Recovery rating based on 81% thermal efficiency

**Recovery rating based on 80% thermal efficiency

STATE TITAN® POWER GAS BURNER



POWERED GAS BURNER

- Premix burner operation
- Safety features: Internal blocked flue sensor, separate pilot system, internal thermal cutoff and anti-flashback barrier

CATEGORY 1 VENTING

- Conventional atmospheric venting on GPG models only with supplied Barometric Draft damper

AUTOMATIC CONTROLS

- Safety shut-off, high-temperature limit control
- Dual thermostat for accurate temperature adjustment from 120°F to 180°F

3-YEAR LIMITED TANK AND 1-YEAR LIMITED PARTS WARRANTY

- For complete warranty information, consult written warranty or go to statewaterheaters.com



Model Number	BTU Input Per Hour	Tank Size	GPH	Recovery Gallons Per Hour Temperature Rise	Maximum Amperes 120V, 60 Hz, 1
				100°	
GPG81-270NE-(A)	270,000	81	GPH	262	5
GPG81-370NE-(A)**	370,000	81	GPH	359	5

** GPG81 370NE available in Natural Gas only.

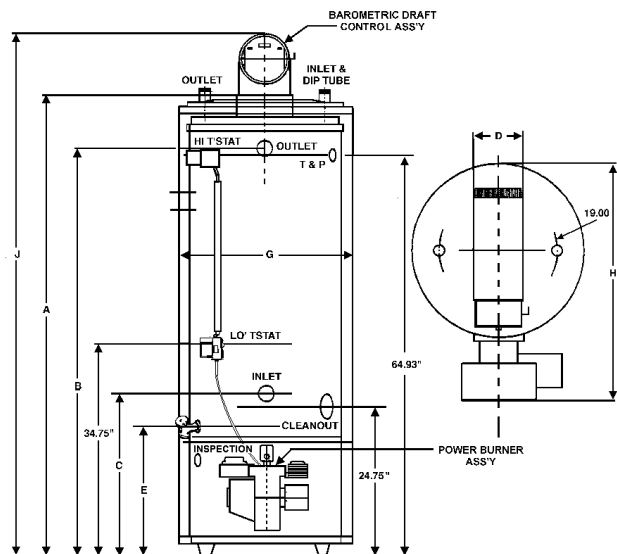

Model Number	Dimensions in Inches				
	A	B	C	D	E
GPG81-270NE-(A)	74-3/4	65	26-3/4	6	21-3/8
GPG81-370NE-(A)**	74-3/4	65	26-3/4	6	21-3/8

Model Number	Dimensions in Inches			Approx. Shipping Weight	
	G	H	J	Standard	ASME
GPG81-270NE-(A)	27-3/4	38	85-1/4	547 lbs	632 lbs
GPG81-370NE-(A)**	27-3/4	38	85-1/4	547 lbs	632 lbs

** GPG81-370NE available in Natural Gas only.
 Specify when ordering propane (LP) gas.
 "A" in the model number represents ASME construction.
 Change "N" to "P" in the model number for Propane.
 Burner and barometric control packaged separately.

STATE TITAN® LOW NO_x POWER GAS BURNER



POWERED GAS LOW NO_x BURNER (NATURAL GAS ONLY)

- Premix burner operation includes internal Flue Gas Recirculation (FGR)
- Safety features: Internal blocked flue sensor, separate pilot system, internal thermal cutoff and anti-flashback barrier

THREE VENTING OPTIONS

- Conventional atmospheric venting on GPG models only with supplied Barometric Draft damper
- Horizontal atmospheric sidewall venting or direct venting on GPV models only
- For sidewall venting order Vent Kit Part # 100125500
- For direct venting order Vent Kit Part # 100131270

AUTOMATIC CONTROLS

- Safety shut-off, high-temperature limit control
- Dual thermostat for accurate temperature adjustment from 120°F to 180°F

3-YEAR LIMITED TANK AND 1-YEAR LIMITED PARTS WARRANTY

- For complete warranty information, consult written warranty or go to statewaterheaters.com



Model Number	Gallon Capacity GPH @ 100°F Rise	Input/BTU/HR Natural Gas	Recovery Capacity	Approx. Shipping Weight (lbs)
GPG85-540NEA	85	540,000	523	950
GPG85-650NEA	85	650,000	630	950
GPG85-740NEA	85	740,000	718	950

Not available in propane (LP).

Vent Kit included in unit price when ordered with heater.

Authorized start-up service included; required to activate warranty. (Continental U.S. only).

For direct or sidewall vent change the last letter in the model to "V" (example: GPV85-540NEA).

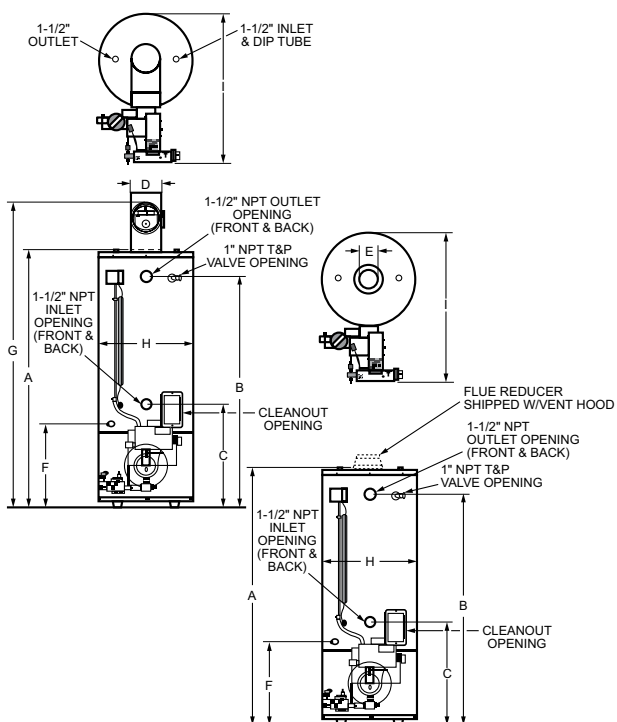

Model Number	Dimensions in Inches				
	A	B	C	D	E
GP685-540NEA	80-3/4	73	32-1/4	9	26-1/2
GP685-650NEA	80-3/4	73	32-1/4	9	26-1/2
GP685-740NEA	80-3/4	73	32-1/4	9	26-1/2

Model Number	Dimensions in Inches			
	F	G	H	I
GP685-540NEA	26-1/2	93	29-1/2	48-1/2
GP685-650NEA	26-1/2	93	29-1/2	48-1/2
GP685-740NEA	26-1/2	93	29-1/2	48-1/2

Not available in propane (LP).

Vent Kit included in unit price when ordered with heater.

Authorized start-up service included; required to activate warranty. (Continental U.S. only).

For direct vent or sidewall change the last letter in the model to "V" (example: GPV85-540NEA).

STATE TITAN® LV POWER GAS

HEAVY-DUTY TPG



POWER GAS BURNER

- Suitable for natural or propane gas
- Electronic flame safeguard control with intermittent spark ignition
- Main and pilot automatic gas valves with gas pressure regulators
- Diaphragm air switch for proof of blower operation
- Flame inspection port

FULLY AUTOMATIC CONTROLS WITH SAFETY SHUTOFF

- High-temperature limit control (manual reset)
- CSA certified and ASME rated T&P relief valve
- Hinged door control compartment with key lock for ease of access
- Two thermostats, upper and lower, for accurate temperature control
- Standard control is for 120°-180°F water service
- Factory-installed low-water cutoff

BLUE DIAMOND® GLASS COATING

- Provides superior corrosion resistance compared to the industry-standard glasslining

CODES AND STANDARDS

- Design-certified by UL (Underwriters Laboratories), according to ANSI Z21. 10.3-4.3 CSA Standards
- Meets the thermal efficiency and standby loss requirements of the U.S. Department of Energy and current edition of ASHRAE/IES 90.1

Optional Low Nox Burners		VTPN/NMP Motor HP
Available Low Nox Burner BTU Input Sizes (Nat. Gas Only)	BTUH	
	400,000	1/4 HP
	540,000	
	600,000	
	720,000	
	800,000	1/2 HP
	1,000,000	
	1,250,000	
	1,500,000	1 HP
	1,750,000	
2,000,000		

Low NOx not available in LP.

Change G to X when ordering Low NOx units. Example TPX140 400NE



Model Number	Gallon Capacity	Input BTU/HR	Recovery Capacity GPH @ 100°F Rise	Approx. Shipping Weight (lbs)
TPG150-140NEA	163	140,000	136	1292
TPG150-199NEA	163	199,000	193	1292
TPG150-255NEA	163	255,000	247	1292
TPG150-270NEA	163	270,000	262	1397
TPG150-400NEA	151	400,000	388	1397
TPG150-540NEA	151	540,000	524	1505
TPG150-720NEA	145	720,000	698	1510
TPG200-300NEA	221	300,000	291	2098
TPG200-600NEA	221	600,000	582	2098
TPG200-800NEA	221	800,000	776	2103
TPG200-1000NEA	221	1,000,000	970	2103
TPG200-1250NEA	210	1,250,000	1212	2467
TPG200-1500NEA	201	1,500,000	1454	2757
TPG300-300NEA	300	300,000	291	2150
TPG300-600NEA	300	600,000	582	2150
TPG300-800NEA	411	800,000	776	2308
TPG300-1000NEA	411	1,000,000	970	2308
TPG300-1250NEA	411	1,250,000	1212	2584
TPG300-1500NEA	411	1,500,000	1454	2774
TPG400-600NEA	411	800,000	776	3207
TPG400-800NEA	411	800,000	776	3212
TPG400-1000NEA	411	1,000,000	970	3212
TPG400-1250NEA	411	1,250,000	1212	3212
TPG400-1500NEA	411	1,500,000	1454	3528
TPG400-1750NEA	404	1,750,000	1697	3669
TPG400-2000NEA	397	2,000,000	1939	3667
TPG600-720NEA	594	720,000	698	3667
TPG600-1000NEA	594	1,000,000	970	3667
TPG600-1250NEA	594	1,250,000	1212	3667
TPG600-1500NEA	594	1,500,000	1454	3837
TPG600-1750NEA	594	1,750,000	1697	3837
TPG600-2000NEA	594	2,000,000	1939	3837
TPG600-2250NEA	585	2,250,000	2182	4477
TPG600-2500NEA	575	2,500,000	2424	4619

Specify when ordering propane (LP) gas.

Change G to X when ordering Low NOx units. Example TPX140-400NE

Dimensions and Line Drawings on the following pages.

STATE TITAN® LV POWER GAS

HEAVY-DUTY TPG (CONTINUED)

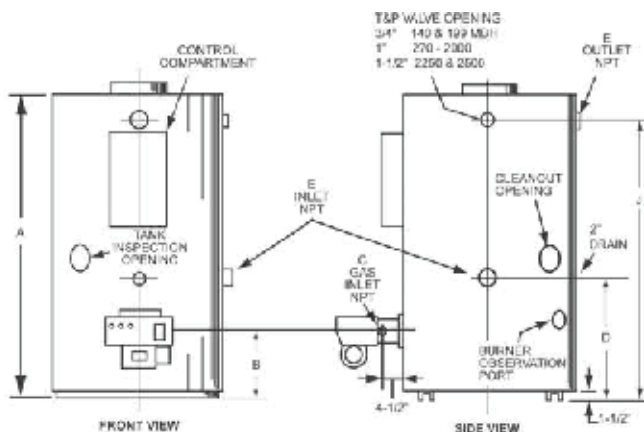
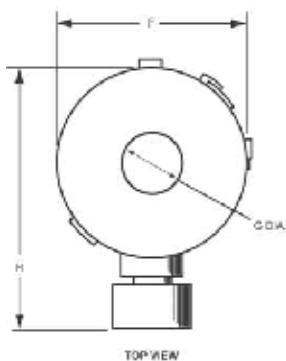

Model Number	Dimensions in Inches								
	A	B	C	D	E	F	G	H	J
TPG150-140NEA	82-1/4	13-1/2	1/2	29-1/4	1-1/4	36-1/2	5	47	73-1/2
TPG150-199NEA	82-1/4	13-1/2	1/2	29-1/4	1-1/4	36-1/2	6	47	73-1/2
TPG150-255NEA	82-1/4	13-1/2	1/2	29-1/4	1-1/4	36-1/2	6	47	73-1/2
TPG150-270NEA	82-1/4	13-1/2	1	29-1/4	1-1/4	36-1/2	6	57-1/2	73-1/2
TPG150-400NEA	82-1/4	13-1/2	1	29-1/4	1-1/4	36-1/2	7	57-1/2	73-1/2
TPG150-540NEA	82-1/4	13-1/2	1	29-1/4	1-1/4	36-1/2	8	57-1/2	73-1/2
TPG150-720NEA	82-1/4	13-1/2	1-1/4	29-1/4	1-1/4	36-1/2	10	57-1/2	73-1/2
TPG200-300NEA	84-1/2	17-1/2	1	34-3/4	1-1/2	44-3/4	6	66-1/2	74-3/4
TPG200-600NEA	84-1/2	17-1/2	1	34-3/4	1-1/2	44-3/4	8	66-1/2	74-3/4
TPG200-800NEA	84-1/2	17-1/2	1-1/4	34-3/4	1-1/2	44-3/4	10	66-1/2	74-3/4
TPG200-1000NEA	84-1/2	17-1/2	1-1/4	34-3/4	1-1/2	44-3/4	10	66-1/2	74-3/4
TPG200-1250NEA	84-3/4	13-1/2	1-1/4	29-1/2	1-1/2	44-3/4	12	66-1/2	75
TPG200-1500NEA	84-3/4	13-1/2	1-1/2	29-1/2	1-1/2	44-3/4	12	81-1/2	75
TPG300-300NEA	92	14	1	29-1/4	1-1/2	44-3/4	6	66-1/2	82-1/2
TPG300-600NEA	92	14	1	29-1/4	1-1/2	44-3/4	8	66-1/2	81-1/2
TPG300-800NEA	92	14	1-1/4	29-1/4	1-1/2	44-3/4	10	66-1/2	81-1/2
TPG300-1000NEA	92	14	1-1/4	29-1/4	1-1/2	44-3/4	10	66-1/2	81-1/2
TPG300-1250NEA	92	14	1-1/4	29-1/4	1-1/2	44-3/4	12	66-1/2	81-1/2
TPG300-1500NEA	92	14	1-1/2	29-1/4	1-1/2	44-3/4	12	81-1/2	81-1/2
TPG400-600NEA	89	17-1/2	1	33-1/4	2	55	8	76-1/2	78-3/4
TPG400-800NEA	89	17-1/2	1-1/4	33-1/4	2	55	10	76-1/2	78-3/4
TPG400-1000NEA	89	17-1/2	1-1/4	33-1/4	2	55	10	76-1/2	78-3/4
TPG400-1250NEA	89	17-1/2	1-1/4	33-1/4	2	55	12	76-1/2	78-3/4
TPG400-1500NEA	89	17-1/2	1-1/2	33-1/4	2	55	12	91-1/2	78-3/4
TPG400-1750NEA	89	17-1/2	2	33-1/4	2	55	14	91-1/2	78-3/4
TPG400-2000NEA	96-1/4	17-1/2	2	33-1/4	2	55	14	91-1/2	86-1/2
TPG600-720NEA	114	17-1/2	1-1/4	33-1/4	2	55	10	76-1/2	105
TPG600-1000NEA	114	17-1/2	1-1/4	33-1/4	2	55	10	76-1/2	105
TPG600-1250NEA	114	17-1/2	1-1/4	33-1/4	2	55	12	76-1/2	105
TPG600-1500NEA	114	17-1/2	1-1/2	33-1/4	2	55	12	91-1/2	105
TPG600-1750NEA	114	17-1/2	2	33-1/4	2	55	14	91-1/2	105
TPG600-2000NEA	114	17-1/2	2	33-1/4	2	55	14	91-1/2	105
TPG600-2250NEA	114	17-1/2	2	33-1/4	2	55	16	91-1/2	105
TPG600-2500NEA	114	17-1/2	2	33-1/4	2	55	14	91-1/2	105

Specify when ordering propane (LP) gas.

Change G to X when ordering Low NOx units. Example TPX140-400NE

STATE TITAN® POWER BURNER GPO SERIES OIL



EFFICIENT COMBUSTION CHAMBER

- Precast, high temperature combustion chamber made of alumina silica ceramic fiber. Engineered for maximum insulation and heat reflection. Unique design assures more complete combustion by stabilizing flame pattern.

BAROMETRIC DRAFT REGULATOR

FLAME OBSERVATION PORT

- Permits Convenient Flame Check

TWO HAND-HOLE CLEANOUTS

- Allows easy cleaning on standard models GPO75 385 OE(A) and larger and ASME models

EASY-TO-INSTALL BURNER

- Three bolt mounting of burner assures easy installations

3-YEAR LIMITED TANK AND 1-YEAR LIMITED PARTS WARRANTY

- For complete warranty information consult written warranty or go to statewaterheaters.com



1" N.P.T. T & P RELIEF VALVE
(FRONT OF HEATER)

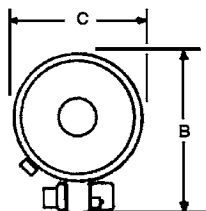
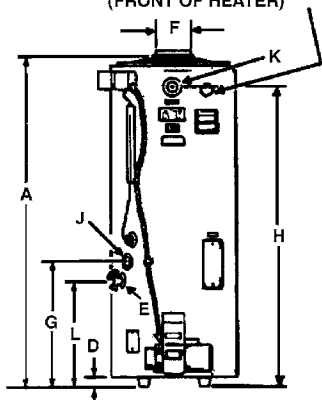



Model Number	Gallon Capacity	Input BTU/HR	Recovery Capacity GPH @ 100°F Rise*	Motor HP	Approx. Shipping Weight (lbs)	
					Standard	ASME
GP086-199-OE	86	199,000	191	1/8	553	N/A
GP086-245-OE	86	245,000	235	1/8	554	N/A
GP084-315-OE(A)	84	315,000	302	1/8	554	657
GP075-385-OE(A)	75	385,000	369	1/8	624	742
GP075-455-OE(A)	75	455,000	436	1/8	700	747
GP069-700-OE(A)	69	700,000	671	1/8	739	822

Model Number	Dimensions in Inches					
	A	B	C	D	E	F
GP086-199-OE	74-1/2	36-3/4	27-3/4	2	3/4 NPT	6
GP086-245-OE	74-1/2	36-3/4	27-3/4	2	3/4 NPT	8
GP084-315-OE(A)	74-1/2	36-3/4	27-3/4	2	3/4 NPT	8
GP075-385-OE(A)	73-3/4	36-3/4	27-3/4	2	3/4 NPT	8
GP075-455-OE(A)	73-3/4	36-3/4	27-3/4	2	3/4 NPT	8
GP069-700-OE(A)	73-3/4	36-3/4	27-3/4	2	3/4 NPT	10

Model Number	Dimensions in Inches				
	G	H	J	K	L
GP086-199-OE	26-5/8	74-1/2	1-1/2 NPT	1-1/2 NPT	22-3/4
GP086-245-OE	26-5/8	74-1/2	1-1/2 NPT	1-1/2 NPT	22-3/4
GP084-315-OE(A)	26-5/8	74-1/2	1-1/2 NPT	1-1/2 NPT	22-3/4
GP075-385-OE(A)	24-3/4	73-3/4	1-1/2 NPT	1-1/2 NPT	23-7/16
GP075-455-OE(A)	24-3/4	73-3/4	1-1/2 NPT	1-1/2 NPT	23-7/16
GP069-700-OE(A)	30-3/16	79-3/16	1-1/2 NPT	1-1/2 NPT	28-7/8

ASME models have "A" at the end of the model number

Based on No. 2 fuel oil. All models have 1/8 HP motor.

Burner and Barometric packaged separately.

Authorized start-up service included - Required to activate warranty, contact factory

Electrical characteristics 120V, 60Hz A.C.

PATRIOT™

LIGHT-SERVICE ELECTRIC



Designed for light duty commercial applications with intermittent hot water loads

GLASSLINED TANK

- Tank interior is coated with glass specially designed by State Water Heaters for water heater use

HEATING ELEMENTS

- Two 4.5 KW zinc plated copper sheathed elements are standard

STANDARD VOLTAGES

- The standard voltage is 240V single phase

TOP MOUNTED RECESSED JUNCTION BOX

CONTROLS

- Thermostat is adjustable through a range of 120° to 181°F with a manual reset high temperature cutoff. The heater is wired for non-simultaneous single phase operation.

COREGARD™ ANODE ROD

- Our anode rods have a stainless steel core that extends the life of the anode rod allowing superior tank protection for longer than standard anode rods

ENHANCED-FLOW BRASS DRAIN VALVE

- Solid brass, tamper resistant, enhanced-flow, ball type, drain valve

MAXIMUM WORKING PRESSURE 150 PSI

FACTORY INSTALLED CSA CERTIFIED AND ASME RATED TEMPERATURE AND PRESSURE RELIEF VALVE

CERTIFIED TO UL 1453 FOR COMMERCIAL ELECTRIC WATER HEATERS

COMPLIANCE

- Meets the standby loss requirements of the U.S. Department of Energy and current edition of ASHRAE/IES 90.1

WARRANTY

- 6-year limited tank/1-year limited parts
- For complete information consult the written warranty or statewaterheaters.com

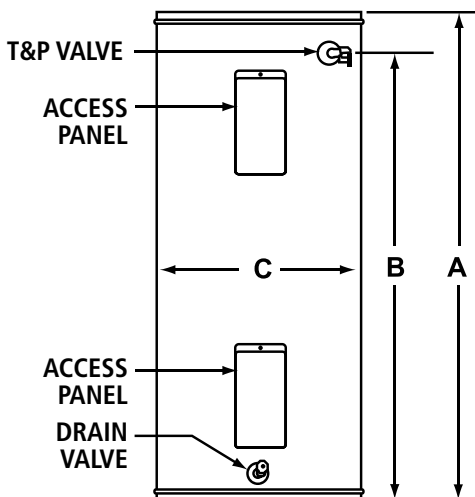
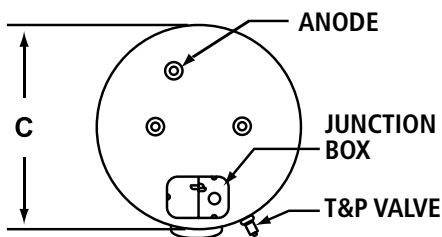

Model Number	Gallon Capacity	Standard Element Wattage 240 VAC	Dimensions in Inches				Approx. Shipping Weight (lbs)
			A	B	C	D	
EDT-6620RT	66	4500	60-1/4	53	22	8	146
EDT-8020RT	80	4500	60-1/2	52-1/4	24	8	175
EDT-12020RT	119	4500	61-1/2	54-1/2	28	8	268

Not available with top mounted T&P valve option

PATRIOT™

LIGHT-DUTY ELECTRIC



GLASSLINED TANK

- Thirteen sizes, 6 thru 119 gallon capacity
- Tank interior is coated with glass specially designed by State for water heater use

ELEMENTS

- Zinc plated copper sheaths for longer life. Medium watt density means lower surface temperature to minimize scale build-up and more surface to heat water. Element sizes from 1.5 to 6 KW. Maximum input 12 KW

STANDARD VOLTAGES

- 120, 277 single phase and 208, 240 and 480V unbalanced three-phase delta; easily converted to single-phase at terminal block (except 208V with 6000 watt elements)
- Single element heater, single-phase only

TERMINAL BLOCK

- Factory-installed. Just bring the service to heater and connect to block. Terminal block not supplied on 120V & 277 volt models.

Element Wattage (Upper/Lower)	U. S. Gallons/Hr at Temperature Rise Indicated	
	F°	100
Non-Simultaneous Operation		
/1500	GPH	6
/2000	GPH	8
/2500	GPH	10
3000/3000	GPH	12
4000/4000	GPH	16
4500/4500	GPH	18
5000/5000	GPH	20
6000/6000	GPH	24
Simultaneous Operation		
3000/3000	GPH	24
4000/4000	GPH	32
4500/4500	GPH	36
5000/5000	GPH	41
6000/6000	GPH	49

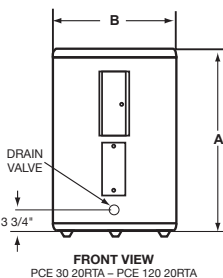
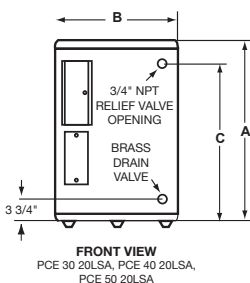
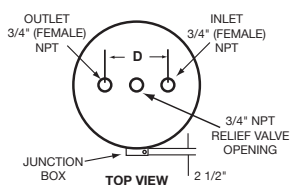
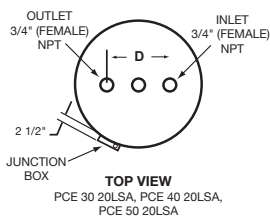
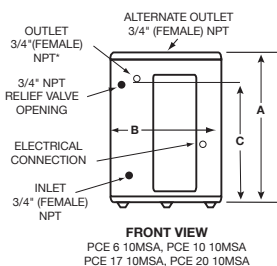
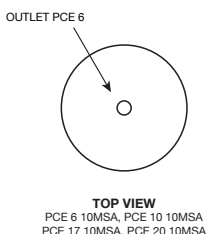

Model Number	No. of Elements	Tank Capacity	A	B	C	D	Approx. Shipping Weight lbs.
		U.S. Gals.	Inches	Inches	Inches	Inches	
PCE-6-10MSA	1	6	15-1/2	14-1/4	11	N/A	35
PCE-10-10MSA	1	10	18-1/4	18	12-1/2	N/A	54
PCE-17-0MSA	1	15	26	18	20-1/2	N/A	58
PCE-20-10MSA	1	20	22-1/4	21-3/4	15-3/8	N/A	73
PCE-30-20LSA	2	30	30-7/8	21-3/4	24-1/8	8	100
PCE-40-20LSA	2	40	32-1/4	24	25-9/16	8	125
PCE-50-20LSA	2	50	32-1/4	26-1/2	25-1/8	8	166
PCE-30-20RTA	2	30	34-1/2	20-1/2	N/A	8	98
PCE-40-20RTA	2	40	45-1/8	20-1/2	N/A	8	113
PCE-52-20RTA	2	50	54-7/8	20-1/2	N/A	8	131
PCE-66-20RTA	2	66	60-3/4	21-3/4	N/A	8	176
PCE-82-20RTA	2	80	59-3/8	24	N/A	8	211
PCE-120-20RTA	2	119	62-7/16	29-3/8	N/A	8	326

SANDBLASTER®

IMMERSION MOUNT THERMOSTAT-CSB SERIES



ADVANCED ELECTRONIC CONTROL

- Plain English Text and Animated Icons Display Diagnostics

ECONOMY MODE OPERATION LOWERS THE OPERATING SET POINT AND REDUCES OPERATING COSTS

THERMOSTATIC LINEAR SEQUENCING CONTROL HELPS REDUCE CURRENT SURGES AND PROVIDES ACCURATE CONTROL OF WATER TEMPERATURE

GOLDENROD ELEMENTS

- All CSB models ship standard with patented Goldenrod 24K gold plated elements. Goldenrod elements provide long life with superior scaling resistance.

3-YEAR LIMITED TANK AND 1-YEAR LIMITED PARTS WARRANTY

- For complete warranty information, consult written warranty or go to statewaterheaters.com



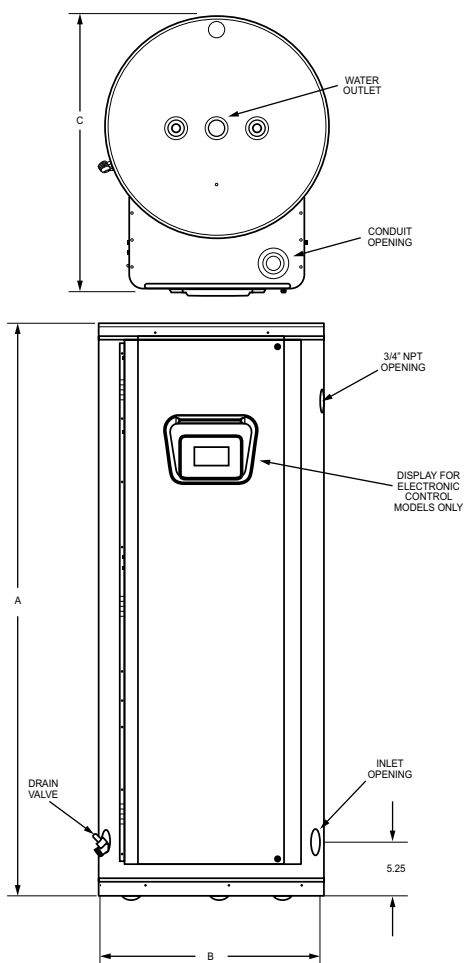

Model Number	Gallon Capacity	Dimensions in Inches			Approx. Shipping Weight
		A	B	C	
CSB-52	50	55-3/4	21-3/4	27	265
CSB-80	80	60-1/4	25-1/2	31	280
CSB-120	119	62-1/4	29-1/2	35	390

See specification sheets or contact your local rep for optional kW's available.
 208 volt models may use three additional elements. 54 kW not available in 208 single phase.

SANDBLASTER®

SURFACE MOUNT THERMOSTATS - CSB SERIES



GOLD ELEMENTS

- CSB models ship with the Goldenrod 24K gold plated elements (see spec sheet for kw options)
- Patented Goldenrod elements provide long life and superior scaling resistance
- Low watt density means lower surface temperature to minimize scale buildup and more surface to heat water. Goldenrod elements carry a one-year warranty against failure due to lime scale buildup.

FUSING

- Protects all elements, thermostats, and internal wiring circuits against excess current flow
- Meets National Electrical Code requirements that non-ASME tanks must have internal fusing when current draw exceeds 48 amps. Available as an option on Canadian built heaters.
- Standard Voltages 208, 240, 277, 480V single-phase and three phase delta. Convertible from three-phase to single-phase (in Field) and Vice Versa (except 208/54kW) 277 single-phase only.



ELEMENT AVAILABILITY

- CSB heaters available from 3kw to 54 KW with recoveries of 25 to 837 GPH at a 100°F rise (CSB-52 has 36kw max)

MEETS THE STANDBY LOSS REQUIREMENTS OF THE U.S. DEPARTMENT OF ENERGY AND CURRENT EDITION OF ASHRAE/IES 90.1

3-YEAR LIMITED TANK AND 1-YEAR LIMITED PARTS WARRANTY

- For complete warranty information, consult written warranty or go to statewaterheaters.com



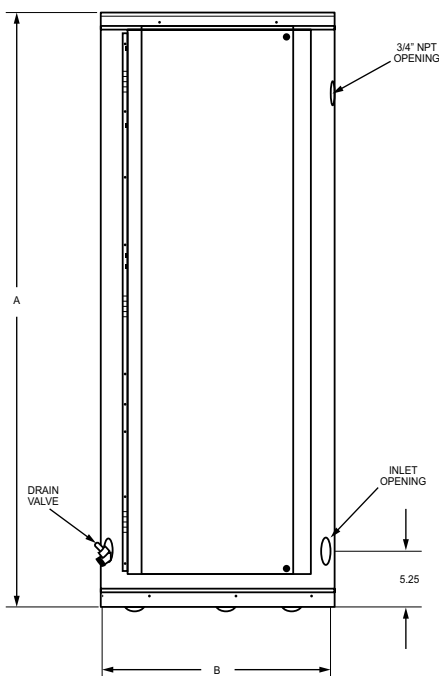
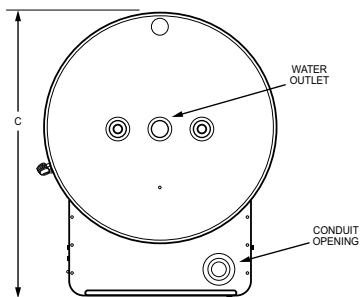

Model Number	Tank Capacity		Dimensions						Inlet/Outlet (NPT)		Approx. Shipping Weight	
			A		B		C					
	gal.	litre	Inches	cm	Inches	cm	Inches	cm	Inches	cm	lbs	kG
CSB-52**	50	189	55-3/4	142	21-3/4	55.2	27	68.6	1-1/4	3.2	265	120
CSB-80	80	300	60-1/4	153	25-1/2	64.8	31	78.7	1-1/4	3.2	280	127
CSB-120	119	450	62-1/4	158.1	29-1/2	75	35	88.9	1-1/4	3.2	390	177

208 volt models may use three additional elements. 54 kW not available in 208 single phase.

For ASME tank construction add "A" to the model number.

**CSB-52 is maximum 36kW.

STATESMAN™

PREMIUM HEAVY-DUTY ELECTRIC - SSE SERIES



ADVANCED ELECTRONIC CONTROL

- Provides Precise Temperature Control and Plain English Text with Animated Icons Displayed

LOW-WATER CUTOFF-REMOTE ELECTRONIC IMMERSION-TYPE PROBE TO PREVENT ENERGIZING OF THE ELEMENTS, ELIMINATING ACCIDENTAL DRY FIRING

INCOLOY-SHEATH HEATING ELEMENTS STANDARD

FACTORY-WIRED, 120V CIRCUIT CONTROLS

POWER-CIRCUIT FUSING FOR SYSTEM PROTECTION

GLASS-LINED TANK WITH ASME CONSTRUCTION

CSA CERTIFIED AND ASME RATED T&P RELIEF VALVE

BACNET AND MODBUS COMPATIBLE WITH ICC INTERFACE

3-YEAR LIMITED TANK AND 1-YEAR LIMITED PARTS WARRANTY

- For complete warranty information, consult written warranty or go to statewaterheaters.com



Low Lead Content

HLW

AHRI CERTIFIED®
www.ahridirectory.org

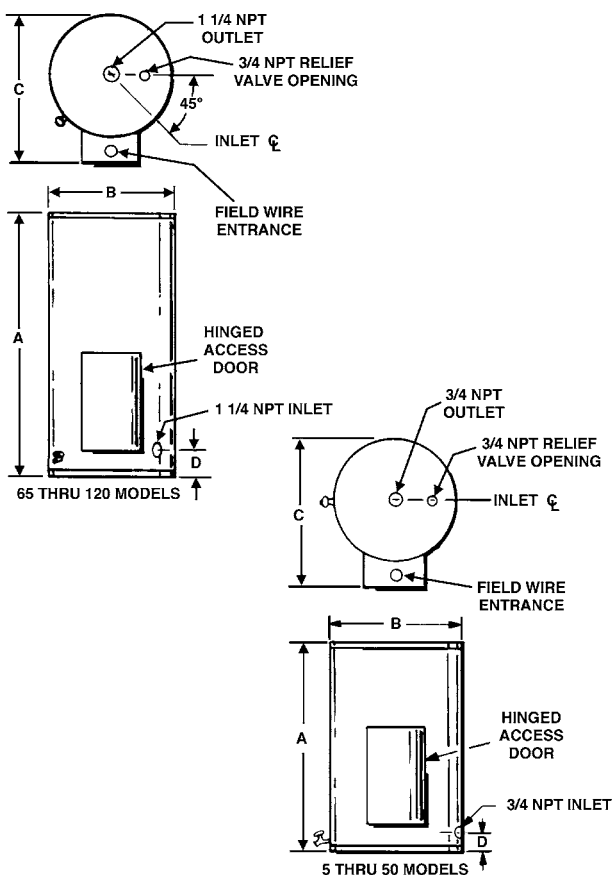

Model Number	Tank Capacity Gallons	Maximum kW Input	Dimensions in Inches				Approx. Shipping Weight lbs.
			A	B	C	D	
SSE-5	5	3	20-1/4	16-1/4	22-1/2	5-1/4	82
SSE-10	10	6	26-1/4	18-3/4	25	5-1/4	116
SSE-20	20	18	27-1/4	20-1/2	26-1/2	5-3/4	145
SSE-30	30	24	35-3/4	20-1/2	26-1/2	5-3/4	150
SSE-40	40	36	45-3/4	20-1/2	26-1/2	5-3/4	190
SSE-50	50	90	54-3/4	20-1/2	26-1/2	5-3/4	221
SSE-65	65	90	54	26-1/2	33-1/2	7	280
SSE-80	80	90	52-1/4	28	35	7	285
SSE-100	100	90	60-1/2	28	35	7	354
SSE-120	120	90	65-1/2	30	37	7-1/2	420

FULLY INTEGRATED HEAT PUMP



ENERGY SAVING & ENVIRONMENTALLY FRIENDLY

- Heat pump transfers heat from surrounding area into the tank
- Industry leading 4.2 COP
- Multiple operating modes maximize efficiency while meeting specific hot water needs
- Integrated, large capacity tank enables heat pump to operate more frequently than electric elements, saving money
- Meets standby loss requirements of U.S. Department of Energy and current edition of ASHRAE 118.1

COMMERCIAL PERFORMANCE

- First hour delivery of 150 GPH
- Electric heating element capacity of 12 kW (240Vac)
- Max. water temperature of 150°F in Efficiency/Hybrid modes and 180°F in Electric mode
- Ambient room temperature operating range of 40° to 110°F
- Dual evaporator fans maximize performance and provide room cooling
- Low operating sound measured at 59 dB (A)

EASE OF OPERATION

- Integrated design and pre-charged refrigeration system facilitates fast, easy installation
- Large touch screen LCD display allows for mode selection, provides run information and includes troubleshooting alerts and detail
- Three operating modes: Efficiency, Hybrid or Electric

DEPENDABLE & LONG LASTING DESIGN

- State-developed glass coated tank
- Tank rated at 160 PSI working pressure
- Commercial grade anode protects the tank and extends service life
- Electric elements have incoloy sheathing and provide excellent protection from oxidation and scaling

3-YEAR LIMITED TANK AND 1-YEAR LIMITED PARTS/COMPRESSOR WARRANTY

- For complete warranty information, consult written warranty or go to statewaterheaters.com

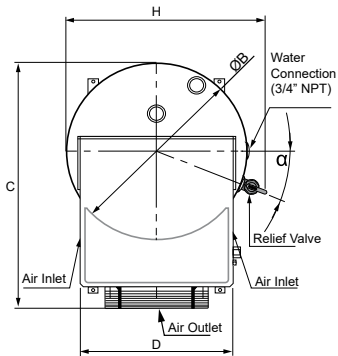
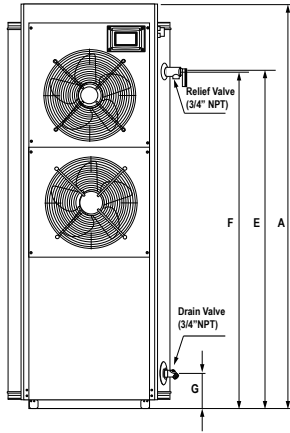

Model Number	Gallon Capacity	COP	Number of Elements
CSHP-120	119	4.2	2

Total Element Wattage (both elements @ 240V)	First Hour Delivery in Hybrid Mode (GPH)	Recovery in GPH at 100° Temperature Rise	Approx. Shipping Weight (lbs)
12,000	150	Efficiency = 41 Hybrid = 90 Electric = 50	620

STANDARD JACKETED STORAGE TANKS



GLASSLINED TANK

- Alkaline borosilicate composition permanently fused to steel by firing at a temperature of 1600°F, providing years of corrosion protection and dependable use

IDEAL FOR USE WITH GAS FIRED COPPER HEAT EXCHANGER EQUIPMENT FOR POTABLE WATER AT TEMPERATURES UP TO 180°F THREADED OPENINGS

- All tanks furnished with threaded openings for thermometer, relief valve, 2" recirculation lines, tankstat, and drain valve

ASME CONSTRUCTION ON SELECT MODELS

- 160 psi standard working pressure on all ASME models

ANODIC PROTECTION ALL MODELS

- Magnesium anode for anti-corrosion protection

MEETS R12.5 MINIMUM THERMAL INSULATION REQUIREMENTS OF THE U.S. DEPARTMENT OF ENERGY AND CURRENT EDITION OF ASHRAE/IES 90.1

5-YEAR LIMITED TANK AND 1-YEAR LIMITED PARTS WARRANTY

- For complete warranty information, consult written warranty or go to statewaterheaters.com

Model Number	Nominal Gallon Capacity	Overall Length (Inches)	Diameter (Inches)	Approx. Shipping Weight (lbs)	Figure
PVG-0080-00VT- Jacketed-Vertical Only	80	63	25-1/4	236	1
PVG-0120-00VT- Jacketed-Vertical Only	119	62	29-3/8	320	2
PVG-0080-00VTA-125	80	54-7/8	26-1/2	369	3
PVG-0120-00VTA-125	119	61-3/4	28	411	4
PVG-0200-00VSA-125	175	77	32	560	5

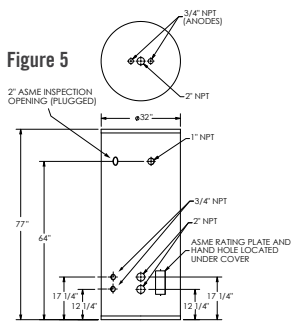
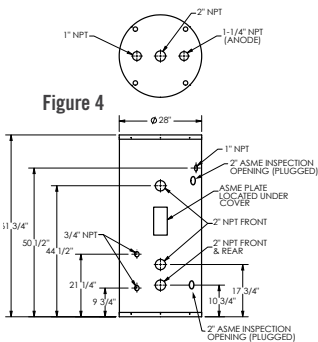
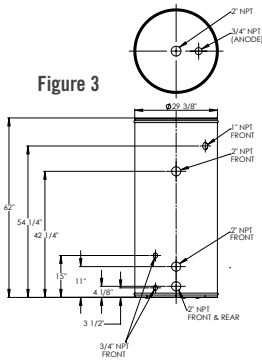
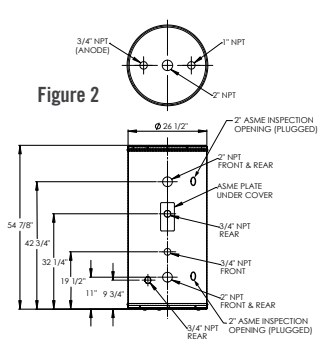
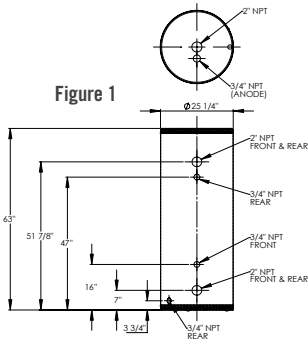

FACTORY JACKETED & INSULATED



STANDARD SIZES

- From 140 to 1,000 gallons; all stock tanks glasslined

HORIZONTAL OR VERTICAL MOUNTING OPTIONS AVAILABLE

HIGH-DENSITY, FIBERGLASS INSULATED JACKETES MEET R12.5 MINIMUM THERMAL INSULATION REQUIREMENTS OF THE U.S. DEPARTMENT OF ENERGY AND CURRENT EDITION OF ASHRAE/IES 90.1

ASME CONSTRUCTION

- Available in 100, 125, 150 and 160 working pressures 125 standard

ANODIC PROTECTION

ACCESSORIES

- Tanks will be supplied with the fittings located as indicated on the drawings unless specified otherwise. An 11" x 15" manhole or 4" x 6" handhole is optional on glasslined tanks 36" diameter or less

CABINET

- Heavy gauge steel with high quality powder coat paint provides additional insulating qualities for greater energy savings

5-YEAR LIMITED TANK WARRANTY

- For complete warranty information consult written warranty or go to statewaterheaters.com

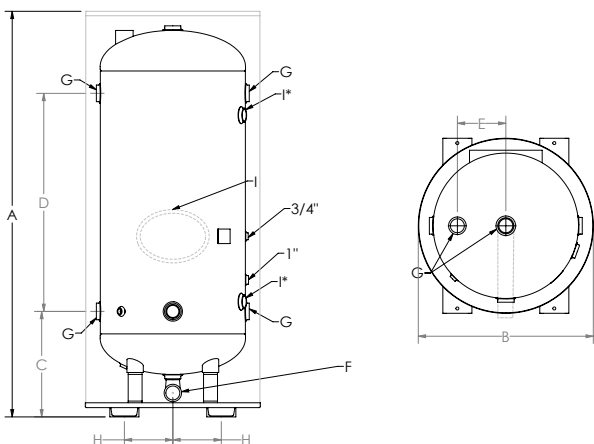

*Note: These connections are not for piping connections. They are the anode locations and also serve as the required ASME 2" inspection openings.

NOTE: • Other tanks to 72" diameter and 3500 gallon are available on special order.

- All openings Female Pipe Thread except as noted.
- "F" opening Male Pipe Thread.

Model Number	Nominal Capacity	A	B	C	D	E	F	G	H	"I" ASME Inspection Openings
PVG-0140-00VTA125	140	87	30	21-1/2	51	8	1-1/2	2-1/2	6-3/8	2"
PVG-0200-00VTA125	200	83	36	22	45	10	1-1/2	2-1/2	7-3/4	2"
PVG-0250-00VTA125	250	96	36	22	58	10	1-1/2	2-1/2	7-3/4	2"
PVG-0350-00VTA125	350	97	42	24-1/2	54	14	1-1/2	2-1/2	9-1/2	2"
PVG-0400-00VTA125	400	105	42	24-1/2	61	14	1-1/2	2-1/2	9-1/2	2"

Working pressure for all models less than 500 gallons is 160 PSI

Continued on the following page.

FACTORY JACKETED & INSULATED (CONTINUED)

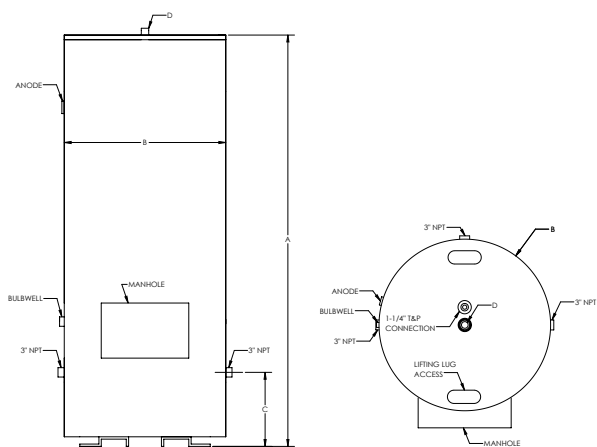

VERTICAL ROUND JACKETED ASME

Model Number	A	B	C	D	Nominal Capacity
PVG-500-00VSA125	91	46	20.75	2"	500
PVG-600-00VTA125	92	52	22.875	2"	600
PVG-700-00VTA125	101	52	22.875	2"	700
PVG-750-00VTA125	104	52	22.875	2"	750
PVG-1000-00VTA125	128	52	22.875	2"	1000

Working Pressure 125 PSI standard, 150 PSI optional

VERTICAL SQUARE JACKETED ASME

Model Number	A	B	C	D	Nominal Capacity
PVG-1250-00VTA125	133	60	24.375	3"	1,250
PVG-1500-00VTA125	129	66	25.875	3"	1,500
PVG-2000-00VTA125	126	78	28.375	3"	2,000

Working Pressure 125 PSI standard, 150 PSI optional

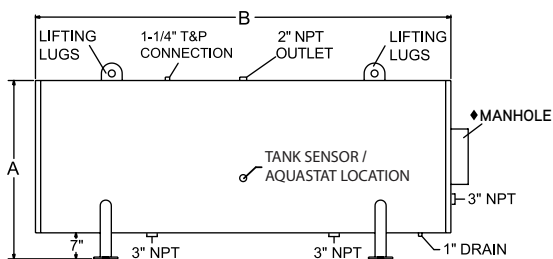

HORIZONTAL ROUND JACKETED ASME TANKS

Model Number	A	B	Diameter	Nominal Capacity
PVG-0250-00HTA125	41	87	34	250
PVG-0300-00HTA125	47	76	40	300
PVG-0400-00HTA125	53	76	46	400
PVG-0500-00HSA125	53	87	46	500
PVG-0600-00HTA125	59	88	52	600
PVG-0700-00HTA125	59	97	52	700
PVG-0750-00HTA125	59	100	52	750
PVG-1000-00HTA125	59	124	52	1000

Working Pressure 125 PSI standard, 150 PSI optional

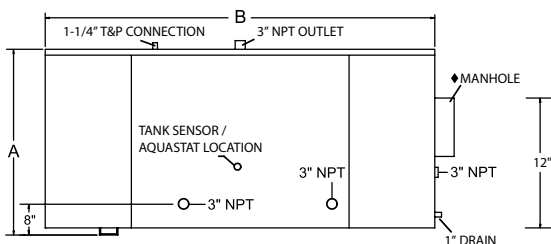

HORIZONTAL SQUARE JACKETED ASME TANKS

Model Number	A	B	Depth	Nominal Capacity
PVG-1250-00HTA125	68.5	134	60.25	1,250
PVG-1500-00HTA125	74.5	127	66.25	1,500
PVG-2000-00HTA125	86.5	127	78.25	2,000
PVG-2500-00HTA125	86.5	144	78.25	2,500

UNINSULATED STANDARD STOCK BARE



GLASSLINED PER ASME, HLW PROCEDURES

HORIZONTAL AND VERTICAL MOUNTING OPTIONS

HIGH-DENSITY, FIBERGLASS INSULATED JACKETS OR BARE STEEL TANKS

CEMENT OR EPOXY LININGS AVAILABLE

ASME CONSTRUCTION

MAGNESIUM ANODES PROTECT AGAINST CORROSION

5-YEAR LIMITED TANK WARRANTY

- For complete warranty information consult written warranty or go to statewaterheaters.com

Model Number	Gallon Capacity	Overall Dimensions in Inches	Approx. Shipping Weight (lbs)
UVG-0800-00VT	80	20 x 62-18	170
UVG-0120-00VT	119	24-1/4 x 65	287
UVG-0200-00VT	200	30 x 72	460
UVG-0350-00VT	350	36 x 88	670
UVG-0140-00VTA125	140	24 x 76-1/4	400
UVG-0200-00VTA125	200	30 x 72	460
UVG-0250-00VTA125	250	30 x 84	505
UVG-0350-00VTA125	350	36 x 88	670
UVG-0400-00VTA125	400	36 x 97	775
UVG-0500-00VTA125	500	42 x 89	815
UVG-0750-00VTA125	750	48 x 106	1290
UVG-01000-00VTA125	1000	48 x 138	1655

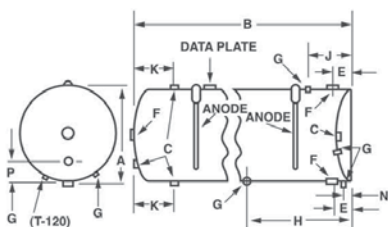

80 AND 120 GALLON MODELS

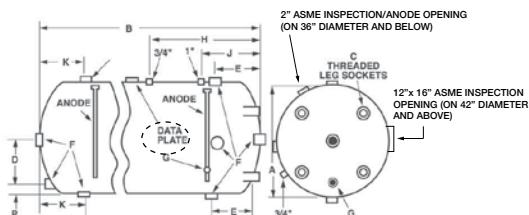

Model Number	Dimensions in Inches					
	A	B	C	D	E	F
UVG-0800-00VT	20	61-1/2	2	N/A	7	2
UVG-0120-00VT	24-1/4	64-3/8	2	N/A	7	2
UVG-0200-00VT	30	70-3/4	2-1/2	10	13	2-1/2
UVG-0350-00VT	36	86	2-1/2	14	16	2-1/2
UVG-0140-00VTA125	24	75	2-1/2	8	12	2-1/2
UVG-0200-00VTA125	30	70-3/4	2-1/2	10	13	2-1/2
UVG-0250-00VTA125	30	84	2-1/2	10	13-1/4	2-1/2
UVG-0350-00VTA125	36	86	2-1/2	14	16	2-1/2
UVG-0400-00VTA125	36	96	2-1/2	14	16	2-1/2
UVG-0500-00VTA125	42	88	3	16	18	3
UVG-0750-00VTA125	48	105	3	18	19-3/4	3
UVG-01000-00VTA125	48	136	3	18	19-3/4	3

Model Number	Dimensions in Inches					
	G	H	J	K	N	P
UVG-0800-00VT	3/4	46-1/4	16	3-1/2	3-1/4	4
UVG-0120-00VT	3/4	34-1/2	15-1/2	10-1/2	3-1/2	4-1/8
UVG-0200-00VT	3/4	28-1/2	19-1/2	13	N/A	4
UVG-0350-00VT	3/4	31-1/2	20-1/4	16	N/A	4
UVG-0140-00VTA125	3/4	27-1/2	18-1/2	12	N/A	4
UVG-0200-00VTA125	3/4	28-1/2	19-1/2	13	N/A	4
UVG-0250-00VTA125	3/4	28-1/2	19-1/2	13	N/A	4
UVG-0350-00VTA125	3/4	31-1/2	20-1/4	16	N/A	4
UVG-0400-00VTA125	3/4	31-1/2	20-1/4	16	N/A	4
UVG-0500-00VTA125	3/4	33-1/2	24-1/2	18	N/A	5
UVG-0750-00VTA125	3/4	32-3/4	26-3/4	19-3/4	N/A	6
UVG-01000-00VTA125	3/4	32-3/4	26-3/4	19-3/4	N/A	6

HEAVY-DUTY LARGE VOLUME STORAGE TANKS



OPTIONAL

CUSTOMER BUILT TANKS FROM 80 TO 12,500 GALLONS

HORIZONTAL OR VERTICAL MOUNTING OPTIONS AVAILABLE

HIGH-DENSITY, FIBERGLASS INSULATED JACKETS OR BARE STEEL TANKS

GLASSLINED, CEMENT OR EPOXY LININGS AVAILABLE

ASME CONSTRUCTION

- Available in 125, 150 and 160 psi working pressure

ANODIC PROTECTION

MANHOLES, HANDHOLES, HEATING COILS, ADDITIONAL TANK OPENING, M LIFTING LUGS, ANGLE LEGS, RING BASES AND HORIZONTAL TANKS SADDLES ALL AVAILABLE AS OPTIONS

INSULATED TANKS MEET R12.5 MINIMUM THERMAL INSULATION REQUIREMENTS OF THE U.S. DEPARTMENT OF ENERGY AND CURRENT EDITION OF ASHRAE/IES 90.1

5-YEAR LIMITED TANK AND 1-YEAR LIMITED PARTS WARRANTY

- For complete warranty information, consult written warranty or go to statewaterheaters.com

Model Number	Gallon Capacity	Diameter (Inches)	Nominal Approx. O. A. Length	Model Number	Diameter (Inches)	Nominal Approx. O. A. Length	Gallon Capacity
UGV-20-00080-VA125	80	20	60"	UGV-54-00650-VA125	54	71"	650
UGV-20-000100-VA125	100	20	72"	UGV-54-00750-VA125	54	81"	750
UGV-24-00125-VA125	125	24	66"	UGV-54-00900-VA125	54	95"	900
UGV-24-00140-VA125	150	24	75"	UGV-54-01000-VA125	54	105"	1,000
UGV-24-00175-VA125*	175	24	90"	UGV-54-01250-VA125*	54	129"	1,250
UGV-30-00175-VA125	175	30	60"	UGV-54-01500-VA125*	54	153"	1,500
UGV-30-00200-VA125	200	30	71"	UGV-54-01800-VA125*	54	181"	1,800
UGV-30-00250-VA125	250	30	84"	UGV-60-00800-VA125*	60	72"	800
UGV-30-00300-VA125*	300	36	99"	UGV-60-01000-VA125*	60	88"	1,000
UGV-36-00250-VA125	250	36	60"	UGV-60-01250-VA125*	60	107"	1,250
UGV-36-00300-VA125	300	36	71"	UGV-60-01500-VA125*	60	126"	1,500
UGV-36-00350-VA125	350	36	86"	UGV-60-01750-VA125*	60	146"	1,750
UGV-36-00400-VA125	400	36	93"	UGV 60 02000 VA125*	60	165"	2,000
UGV-36-00500-VA125*	500	36	122"	UGV-66-01000-VA125*	66	75"	1,000
UGV-42-00375-VA125	375	42	67"	UGV-66-01500-VA125*	66	107"	1,500
UGV-42-00450-VA125	450	42	79"	UGV-66-02000-VA125*	66	139"	2,000
UGV-42-00500-VA125	500	42	88"	UGV-66-02500 VA125*	66	171"	2,500
UGV-42-00600-VA125	600	42	103"	UGV 72 02500 VA125*	72	147"	2,500
UGV-42-00700-VA125	700	42	119"	UGV 72 03000-VA125*	72	174"	3,000
UGV-42-00800-VA125*	800	42	134"	UGV-72-03500-VA125*	72	201"	3,500
UGV-48-00500-VA125	500	48	73"	UGV-72-04000-VA125*	72	228"	4,500
UGV-48-00600-VA125	600	48	81"	UGV-84-04000-VA125*	84	173"	4,000
UGV-48-00700-VA125	700	48	93"	UGV-84-05000-VA125*	84	212"	5,000
UGV-48-00750-VA125	750	48	105"	UGV-84-06000-VA125*	84	252"	6,000
UGV-48-00900-VA125	900	48	117"	UGV-84-08000-VA125*	84	330"	8,000
UGV-48-01000-VA125	1,000	48	137"	UGV-96-07500-VA125*	96	244"	7,500
UGV-48-01250-VA125	1,250	48	159"	UGV-96-10000-VA125*	96	319"	10,000
UGV-48-01500-VA125	1,500	48	190"	UGV-96-12500-VA125*	96	395"	12,500

HEAVY-DUTY LARGE VOLUME STORAGE TANKS (CONTINUED)

STORAGE TANKS (20" THRU 96" DIA. TANKS)

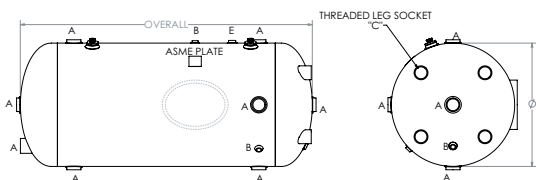

NOTE:

- 1) 54" Diameter and larger tanks must be ordered with angle legs rather than threaded leg sockets for vertical installations.
- 2) Specify for horizontal or vertical installation.
- 3) No leg sockets provided on horizontal tanks.
2 each 2" ASME inspection openings are standard on tanks 36" diameter and below.
12"x16" ASME inspection openings are standard on tanks with 42" diameters and above.

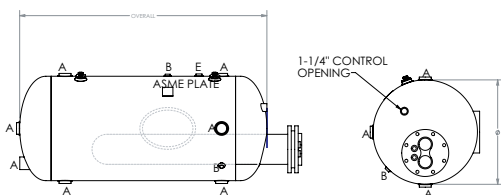

NOTE:

- 1) State Custom Storage Tanks with Heating Coils (Horizontal Configuration)
- 2) Specify for horizontal or vertical installation.
- 3) No leg sockets provided on horizontal tanks.

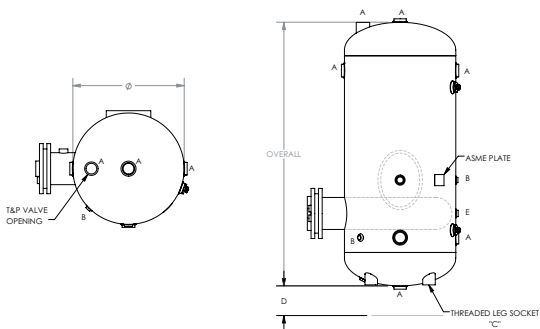

NOTE:

State Custom Storage Tanks with Heating Coils
(Vertical Configuration)

Dimensions in Inches					
	A	B	C	D	E
20	2	3/4	1-1/2	6	3/4
24 thru 36	2-1/2	3/4	2-1/2	8	1
42 thru 48	3	3/4	3	10	1
54 thru 96	3	3/4	3	10	1

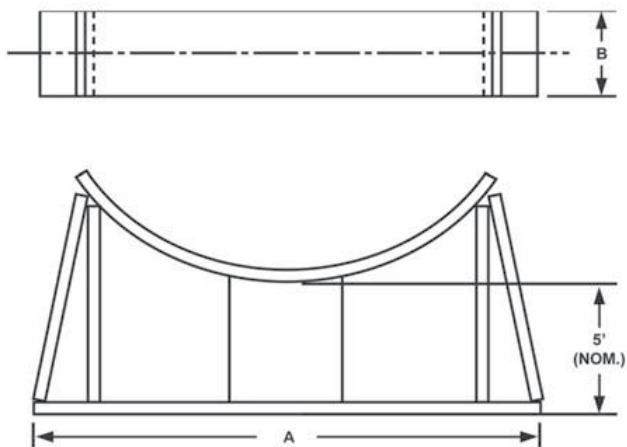

TANK SADDLES

Part No.	Tank Dia.	A	B
P2-2600-20	20	22	6
P2-2600-24	24	26	6
P2-2600-30	30	32	6
P2-2600-36	36	38	6
P2-2600-42	42	44	6
P2-2600-48	48	50	6
P2-2600-54	54	56	8
P2-2600-60	60	62	8
P2-2600-66	66	58	8
P2-2600-72	72	74	10
P2-2600-84	84	86	10

SOLID. STATE.



State Water Heaters | 500 Tennessee Waltz Parkway | Ashland City, TN 37015

800.527.1953 | statewaterheaters.com

SMBCA00106 | © June 2023 State Water Heaters | Printed in U.S.A.