

# Instruction Manual for Residential Power Direct Vent Gas Water Heaters

**NOT FOR USE IN MANUFACTURED (MOBILE) HOMES**



GAMA certification applies to all residential gas water heaters with capacities of 20 to 100 gallons with input rating of 75,000 BTU/Hr. or less.

**ALL TECHNICAL AND WARRANTY QUESTIONS:** SHOULD BE DIRECTED TO THE LOCAL DEALER FROM WHOM THE WATER HEATER WAS PURCHASED. IF YOU ARE UNSUCCESSFUL, PLEASE WRITE TO THE COMPANY LISTED ON THE RATING PLATE ON THE WATER HEATER.

## For Your Safety AN ODORANT IS ADDED TO THE GAS USED BY THIS WATER HEATER

**WARNING:** If the information in these instructions are not followed exactly, a fire or explosion may result, causing property damage, personal injury or death.

- Do not store or use gasoline or other flammable vapors and liquids in the vicinity of this or any other appliance.
- WHAT TO DO IF YOU SMELL GAS
  - Do not try to light any appliance.
  - Do not touch any electrical switch; do not use any phone in your building.
  - Immediately call your gas supplier from a neighbor's phone. Follow the gas supplier's instructions.
  - If you cannot reach your gas supplier, call the fire department.
- Installation and service must be performed by a qualified installer, service agency or the gas supplier.

### WARNING

Improper installation, adjustment, alteration, service or maintenance can cause **DEATH, SERIOUS BODILY INJURY, OR PROPERTY DAMAGE.** Refer to this manual for assistance or consult the local gas utility for further information.

### WARNING

Flammable vapors may be drawn by air currents from other areas of the structure to this appliance.

### WARNING

**READ THE GENERAL SAFETY SECTION BEGINNING ON INSIDE COVER AND THEN THIS ENTIRE MANUAL BEFORE INSTALLING OR OPERATING THIS WATER HEATER.**

# General Safety

## ▲WARNING

Improper installation, adjustment, alteration, service or maintenance can cause DEATH, SERIOUS BODILY INJURY, OR PROPERTY DAMAGE. Refer to this manual or consult your local gas utility for further assistance.

## ▲WARNING

At the time of manufacture this water heater was provided with a combination temperature-pressure relief valve certified by a nationally recognized testing laboratory that maintains periodic inspection of production of listed equipment or materials, as meeting the requirements for Relief Valves and Automatic Gas Shutoff Devices for Hot Water Supply Systems, and the current edition of ANSI Z21.22 and the code requirements of ASME. If replaced, the valve must meet the requirements of local codes, but not less than a combination temperature and pressure relief valve certified as meeting the requirements for Relief Valves and Automatic Gas Shutoff Devices for Hot Water Supply Systems, ANSI Z21.22 by a nationally recognized testing laboratory that maintains periodic inspection of production of listed equipment or materials.

The valve must be marked with a maximum set pressure not to exceed the marked hydrostatic working pressure of the water heater (150 lbs. p.s.i.) and a discharge capacity not less than the water heater input rate as shown on the model rating plate. (Electric heaters - watts divided by 1000 x 3412 equal BTU/Hr. rate.)

Your local jurisdictional authority, while mandating the use of a temperature-pressure relief valve complying with ANSI Z21.22 and ASME, may require a valve model different from the one furnished with the water heater.

Compliance with such local requirements must be satisfied by the installer or end user of the water heater with a locally prescribed temperature-pressure relief valve installed in the designated opening in the water heater in place of the factory furnished valve.

For safe operation of the water heater, the relief valve must not be removed from its designated opening or plugged.

The temperature-pressure relief valve must be installed directly into the fitting of the water heater designated for the relief valve. Position the valve downward and provide tubing so that any discharge will exit only within 6 inches above, or at any distance below the structural floor. Be certain that no contact is made with any live electrical part. The discharge opening must not be blocked or reduced in size under any circumstances. Excessive length, over 30 feet, or use of more than four elbows can cause restriction and reduce the discharge capacity of the valve.

No valve or other obstruction is to be placed between the relief valve and the tank. Do not connect tubing directly to discharge Drain unless a 6" air gap is provided. To prevent bodily injury, hazard to life, or property damage, the relief valve must be allowed to discharge water in quantities should circumstances demand. If the discharge pipe is not connected to a drain or other suitable means, the water flow may cause property damage.

### The Discharge Pipe:

- Must not be smaller in size than the outlet pipe size of the valve, or have any reducing couplings or other restrictions.
- Must not be plugged or blocked.
- Must be of material listed for hot water distribution.
- Must be installed so as to allow complete drainage of both the temperature-pressure relief valve, and the discharge pipe.
- Must terminate at an adequate drain.
- Must not have any valve between the relief valve and tank.

## ▲WARNING

**WATER HEATERS EQUIPPED FOR ONE TYPE GAS ONLY:** This water heater is equipped for one type gas only. Check the model rating plate near the gas control valve for the correct gas. DO NOT USE THIS WATER HEATER WITH ANY GAS OTHER THAN THE ONE SHOWN ON THE MODEL RATING PLATE. Failure to use the correct gas can cause problems which can result in DEATH, SERIOUS BODILY INJURY, OR PROPERTY DAMAGE. If you have any questions or doubts consult your gas supplier or local utility.

## ▲WARNING

A fire can start if combustible materials such as clothing, cleaning materials, or flammable liquids are placed against or next to the water heater.

## ▲WARNING

**INSTALLATIONS IN AREAS WHERE FLAMMABLE LIQUIDS (VAPORS) ARE LIKELY TO BE PRESENT OR STORED (GARAGES, STORAGE, AND UTILITY AREAS, ETC):** Flammable liquids (such as gasoline, solvents, propane (LP) or butane, etc.), all of which emit flammable vapors, may be improperly stored or used in such areas. The gas water heater ignitor or main burner can ignite such vapors. The resulting flashback and fire can cause death or serious burns to anyone in the area, as well as property damage.

If installation in such areas is your only option, then the installation must be accomplished in a way that the ignitor and main burner flame are elevated from the floor at least 18 inches. While this may reduce the chances of flammable vapors from a floor spill being ignited, gasoline and other flammable substances should never be stored or used in the same room or area containing a gas water heater or other open flame or spark producing appliance.

NOTE: Flammable vapors may be drawn by air currents from other areas of the structure to the appliance.

## ▲WARNING

**HOTTER WATER CAN SCALD:** Water heaters are intended to produce hot water. Water heated to a temperature which will satisfy clothes washing, dish washing, and other sanitizing needs can scald and permanently injure you upon contact. Some people are more likely to be permanently injured by hot water than others. These include the elderly, children, the infirm, or physically/mentally handicapped. If anyone using hot water in your home fits into one of these groups or if there is a local code or state law requiring a certain temperature water at the hot water tap, then you must take special precautions. In addition to using the lowest possible temperature setting that satisfies your hot water needs, some type of tempering device, such as a mixing valve, should be used at the hot water taps used by these people or at the water heater. Mixing valves are available at plumbing supply or hardware stores. Follow manufacturers instructions for installation of the valves. Before changing the factory setting on the thermostat, read the "Temperature Regulation" section in this manual.

## ▲WARNING

**BEFORE OPERATING [PROPANE (L.P.) GAS WATER HEATERS]:** Propane (L.P.) gas is heavier than air. Should there be a leak in the system, the gas will settle near the ground. Basements, crawl spaces, skirted areas under manufactured (mobile) homes (even when ventilated), closets and areas below ground level will serve as pockets for the accumulation of this gas. Before attempting to operate the water heater or turning on a nearby electrical light switch, be absolutely sure there is no accumulated gas in the area. Search for odor of gas by sniffing at ground level in the vicinity of the appliance. If odor is detected, follow steps indicated at "For Your Safety" on the cover page of this manual then leave the premises.

# General Safety (cont'd)

## ▲WARNING

This water heater must not be installed directly on carpeting. Carpeting must be protected by a metal or wood panel beneath the appliance extending beyond the full width and depth of the appliance by at least 3 inches (76.2mm) in any direction, or if the appliance is installed in an alcove or closet, the entire floor must be covered by the panel. Failure to heed this warning may result in a fire hazard.

## ▲WARNING

Do not install in a confined area such as a closet, unless you provide ventilation air as shown in the "Locating The New Water Heater" section. Never obstruct the flow of ventilation air. If you have any doubts or questions at all, call your gas company. Failure to provide ventilation air can result in a fire or explosion and can cause DEATH, SERIOUS BODILY INJURY, OR PROPERTY DAMAGE.

## ▲WARNING

If this water heater will be used in beauty shops, barber shops, cleaning establishments, or self-service laundries with dry cleaning equipment, it is imperative that the water heater or water heaters be installed so that combustion and ventilation air be taken from outside these areas. Refer to the "Locating The New Water Heater" section of this manual and also the current edition of the National Fuel Gas Code, ANSI Z223.1, also referred to as NFPA 54 for specifics provided concerning air required.

## ▲WARNING

The power direct vent water heater requires its own (separate) venting system. It cannot be connected to an existing vent pipe or chimney. It must be terminated to the outdoors. Failure to properly install the venting system can result in asphyxiation, a fire or explosion and can cause DEATH, SERIOUS BODILY INJURY, OR PROPERTY DAMAGE.

## ▲WARNING

No vent damper installation is compatible with this power vented water heater design. No vent damper, whether it is operated thermally or otherwise is to be installed on this power vented water heater. Alteration of any part of the factory-furnished vent assembly could result in improper operation due to restriction of flue gases, spillage of flue gases and may cause carbon monoxide poisoning.

## ▲WARNING

1. The appliance and its individual shutoff valve must be disconnected from the gas supply piping system during any pressure testing of the gas system at test pressures in excess of  $\frac{1}{2}$  pound per square inch (3.5kPa).
2. The appliance must be isolated from the gas supply piping system by closing its individual manual shutoff valve during any pressure testing of the gas supply piping system at test pressures equal or less than  $\frac{1}{2}$  pound per square inch (3.5kPa).

## ▲WARNING

Soot build-up indicates a problem that requires correction before further use. Turn "OFF" gas to water heater and leave "OFF" until repairs are made, because failure to correct the cause of the sooting can result in a fire or explosion causing DEATH, SERIOUS BODILY INJURY, OR PROPERTY DAMAGE.

## ▲WARNING

The water heater must be properly vented outdoors. Never operate the water heater unless it is vented to the outdoors and has adequate air supply to avoid risks of improper operation, explosion or asphyxiation.

## ▲WARNING

Vent termination must not be within 4 feet of any items such as gas meters, gas valves or other gas regulating equipment.

## ▲WARNING

Obstructed or deteriorated vent systems may present a serious health risk or asphyxiation.

## ▲WARNING

Chemical vapor corrosion of the flue and vent system may occur if air for combustion contains certain chemical vapors. Spray can propellants, cleaning solvents, refrigerator and air conditioner refrigerants, swimming pool chemicals, calcium and sodium chloride, waxes, bleach, and process chemicals are typical compounds which are potentially corrosive.

## ▲WARNING

Minimum clearances between the water heater and combustible and non-combustible construction are: 0 inches from sides, 0 inches from back, 6 inches from front of jacket to closet door and 12 inches from top of jacket to combustible and non-combustible material. Minimum vent clearance: 0 inches. Provide 24 inches front clearance for servicing and adequate clearance between the jacket top and ceiling for servicing the flue area.

## ▲WARNING

**HYDROGEN GAS:** Hydrogen gas can be produced in a hot water system that has not been used for a long period of time (generally two weeks or more). Hydrogen gas is extremely flammable and explosive. To prevent the possibility of injury under these conditions, we recommend the hot water faucet be opened for several minutes at the kitchen sink before any electrical appliances which are connected to the hot water system are used (such as a dishwasher or washing machine). If hydrogen gas is present, there will probably be an unusual sound similar to air escaping through the pipe as the hot water faucet is opened. There must be no smoking or open flame near the faucet at the time it is open.

## ▲WARNING

**INSULATING JACKETS:** When installing an external water heater insulation jacket on a gas water heater:

- a. DO NOT cover the temperature-pressure relief valve.
- b. DO NOT put insulation over any part of the top of the gas water heater.
- c. DO NOT put insulation over the gas control valve or gas control valve/burner cover, or any access areas to the burner.
- d. DO NOT let insulation around the gas water heater to get within 8 inches of the floor (access for servicing the burner).
- e. DO NOT remove operating instructions, and safety related warning labels and materials affixed to the water heater. DO obtain new warning and instruction labels from the manufacturer for placement on the jacket directly over the existing labels.

Failure to heed this will result in the possibility of a fire or explosion.

## ▲WARNING

Flood damage to a water heater may not be readily visible or immediately detectible. However, over a period of time a flooded water heater will create dangerous conditions which can cause DEATH, SERIOUS BODILY INJURY, OR PROPERTY DAMAGE. Call a qualified service technician or contractor to replace a flooded water heater. Do not attempt to repair the unit! It must be replaced!

## ▲CAUTION

**WATER HEATERS EVENTUALLY LEAK:** Installation of the water heater must be accomplished in such a manner that if the tank or any connections should leak, the flow of water will not cause damage to the structure. For this reason, it is not advisable to install the water heater in an attic or upper floor. When such locations cannot be avoided, a suitable drain pan should be installed under the water heater. Drain pans are available at your local hardware store. Such a drain pan must have a minimum length and width of at least 2 inches greater than the water heater dimensions and must be piped to an adequate drain. Drain pan depth must allow for access to the outer doors for servicing the ignitor and burner.

# Table of Contents

<b>General Safety</b> .....	2-3
<b>Table of Contents</b> .....	4
<b>Introduction</b> .....	5
<b>Preparing for the New Installation</b> .....	5
<b>Typical Installation</b> .....	6
<b>Locating the New Water Heater</b> .....	7-9
Facts to Consider About Location.....	7-8
Combustion Air and Ventilation.....	8-9
Venting Clearances.....	8-9
Air for Ventilation for Appliances Located in Confined Spaces.....	9
<b>Installing the New Water Heater</b> .....	10-20
Water Piping.....	10
Temperature-Pressure Relief Valve.....	11
Filling the Water Heater.....	12
Wiring.....	12-13
Optional Field Installed Wiring.....	12-13
Wiring Diagram.....	13
Venting.....	13-18
Gas Piping.....	18-19
Installation Checklist.....	20
<b>Operating</b> .....	21-23
<b>Temperature Regulation</b> .....	24
<b>For Your Information</b> .....	25-26
Start Up Conditions.....	25
Condensation.....	25
Smoke/Odor.....	25
Thermal Expansion.....	25
Strange Sounds.....	25
Operational Conditions.....	25-26
Smelly Water.....	25
"Air" In Hot Water Faucets.....	26
Venting Manual Reset Switch.....	26
High Temperature Limit Switch.....	26
Not Enough or No Hot Water.....	26
Water Is Too Hot.....	26
<b>Periodic Maintenance</b> .....	27-29
Venting System Inspection.....	27
Burner Inspection.....	27
Burner Cleaning.....	27
L.P. Gas Control Valve & Burner Assembly Replacement Information.....	28
Housekeeping.....	28
Anode Rod Inspection.....	28
Temperature-Pressure Relief Valve Operation.....	29
Draining.....	29
Drain Valve Washer Replacement.....	29
Service.....	29
<b>Leakage Checkpoints</b> .....	30
<b>Troubleshooting</b> .....	31-33
<b>Repair Parts</b> .....	34-37

# Introduction

**Thank You** for purchasing this water heater. When installed according to State and Local Codes and maintained according to the manufacturers instructions, it should give you years of trouble free service.

## Abbreviations Found In This Instruction Manual

CSA - Canadian Standards Association  
ANSI - American National Standards Institute  
NFPA - National Fire Protection Association

### ▲WARNING

**This gas-fired water heater is design certified by CSA International under American National Standard/CSA Standard for Gas Water Heaters, ANSI Z21.10.1 • CSA 4.1 (current edition). The installation must conform with this manual, Local Codes and with the current edition of the National Fuel Gas Code, ANSI Z223.1. This publication is available from your local government or public library, gas company, or by writing NFPA, Batterymarch Park, Quincy, MA 02269.**

# Preparing for the New Installation

1. Read the "General Safety" section, pages 2 and 3 of this manual first and then the entire manual carefully. If you don't follow the safety rules, the water heater will not operate properly. It could cause DEATH, SERIOUS BODILY INJURY AND/OR PROPERTY DAMAGE.  
This manual contains instructions for the installation, operation, and maintenance of the gas-fired water heater. It also contains warnings through out the manual that you must read and be aware of. All warnings and all instructions are essential to the proper operation of the water heater and your safety. Since we cannot put everything on the first few pages, **READ THE ENTIRE MANUAL BEFORE ATTEMPTING TO INSTALL OR OPERATE THE WATER HEATER.**
2. The installation must conform with the instructions in this manual; gas company rules; and Local Codes, or in the absence of Local Codes, with the current edition of the National Fuel Gas code, ANSI Z223.1, also referred to as NFPA 54. This publication is available from your local government or public library or gas company or by writing NFPA, Batterymarch Park, Quincy, MA 02269.
3. If after reading this manual you have any questions or do not understand any portion of the instructions, call the local gas utility or the manufacturer whose name appears on the rating plate.
4. Carefully plan the place where you are going to put the water heater. Correct combustion, vent action, and intake air and exhaust vent pipe installation are very important in preventing death from possible carbon monoxide poisoning and fires.  
Examine the location to ensure the water heater complies with the "Locating the New Water Heater" section in this manual.
5. For California installation this water heater must be braced, anchored, or strapped to avoid falling or moving during an earthquake. See instructions for correct installation procedures. Instructions may be obtained from your local dealer, wholesaler, public utilities or California Office of the State Architect, 400 P Street, Sacramento, CA 95814.
6. Massachusetts Code requires this water heater to be installed in accordance with Massachusetts 248-CMR 2.00: State Plumbing Code and 248-CMR 5.00.
7. Complies with SCAQMD rule #1121 and districts having equivalent NOx requirements.

# Typical Installation

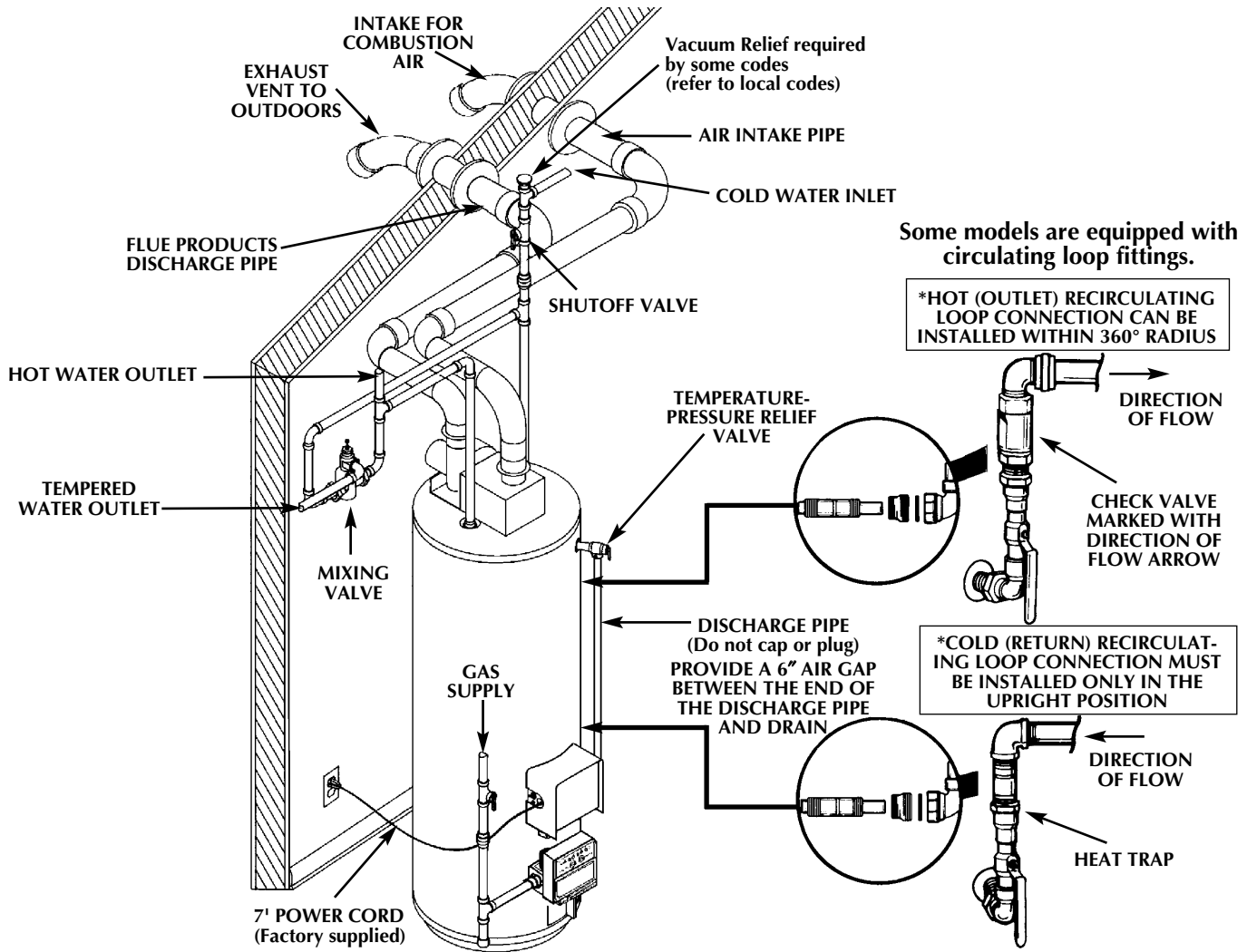

\*Certain models do not have these connection assemblies shipped with the water heater. They (Part #9001262) are available through the manufacturer. See "Repair Parts" section for ordering information.

This appliance has been design certified as complying with American National Standard/CSA Standard for water heaters and is considered suitable for:

**Water (Potable) Heating:** All models are "considered suitable for water (potable) heating."

**Water (Potable) Heating and Space Heating:** Certain models are "considered suitable for water (potable) heating and space heating." Refer to the model and rating plate of the water heater.

## ▲WARNING

When the system requires water at temperatures higher than required for other uses, the hot water system may require a means such as a mixing valve to be installed to temper the water at certain points of use. Some people are more likely to be permanently injured by hot water than others; these include the elderly, children, the infirm, or the physically/mentally handicapped. Before immersing yourself or anyone else in hot water, be sure to check the water temperature. **WARNING: HOTTER WATER INCREASES THE RISK OF SCALD INJURY.** (Also see "Temperature Regulation" section) Mixing valves are available at plumbing supply or hardware stores. Follow manufacturers instructions for installation of these valves.

## ▲WARNING

This water heater shall not be connected to any heating systems or component(s) previously used with a non-potable water heating appliance. If this water heater is also used for space heating applications, all piping and components connected to the water heater shall be suitable for use with potable water.

## ▲WARNING

Toxic chemicals such as used for treatment of boilers or non-potable water heating appliances shall never be introduced into a potable water space heating system.

**NOTE:** To protect against untimely corrosion of hot and cold water fittings, it is strongly recommended that di-electric unions or couplings be installed on this water heater when connected to copper pipe.

# Locating the New Water Heater

## Facts to Consider About the Location

You should carefully choose an indoor location for the new water heater, because the placement is a very important consideration for the safety of the occupants in the building and for the most economical use of the appliance. **This water heater is not for use in manufactured (mobile) homes or outdoor installation.**

Whether replacing an old water heater or installing the water heater in a new location, the following critical points must be observed.

1. The location selected should be indoors as close as practical to the vent termination point, and as centralized with the water piping system as possible. The water heater, as all water heaters, will eventually leak. Do not install without adequate drainage provisions where water flow will cause damage.
2. If vented through an outside wall or through the roof using 3" vent piping, the total vent run (vertical and horizontal) cannot exceed a total of 45 feet with one elbow. If more elbows are required, the venting distance must be reduced 5 feet for every 90° elbow. See page 15 for vent chart.
3. Vent piping cannot slope downward and horizontal runs require 1/8" per five foot rise. All horizontal runs require adequate support at 3 1/2 foot intervals and vertical runs supported at 5 foot intervals.
4. The water heater **requires its own** (separate) venting system. It **cannot** be connected to an existing vent pipe or chimney. It must terminate to the outdoors. Whenever possible terminate the vent on the leeward side of the building through an outside wall. **Note: Condensation may be created, at times, as the combustion gases exit the vent cap and discoloration of surfaces in proximity to the vent cap may occur.**

### ▲WARNING

The power direct vent water heater requires its own (separate) venting system. It cannot be connected to an existing vent pipe or chimney. It must be terminated to the outdoors. Failure to properly install the venting system can result in asphyxiation, a fire or explosion and can cause DEATH, SERIOUS BODILY INJURY, OR PROPERTY DAMAGE.

5. The water heater comes equipped with a 7 foot power cord which can be used to connect to a 110/120 volt power source if (1) local codes allow, and (2) there is a three prong receptacle available.

### ▲WARNING

Do not use an extension cord. If there is not a suitable receptacle with ground and/or local codes prohibit use of a power cord, field wiring must be provided.

### ▲CAUTION

**WATER HEATERS EVENTUALLY LEAK:** Installation of the water heater must be accomplished in such a manner that if the tank or any connections should leak, the flow of water will not cause damage to the structure. When such locations cannot be avoided, a suitable drain pan should be installed under the water heater. Drain pans are available at your local hardware store. Such a drain pan must have a minimum length and width of at least 2 inches greater than the water heater dimensions and must be piped to an adequate drain. Drain pan depth must allow for access to the outer doors for servicing the ignitor and burner.

6. The location selection must provide adequate clearances for servicing and proper operation of the water heater.

### ▲WARNING

**INSTALLATION IN AREAS WHERE FLAMMABLE LIQUIDS (VAPORS) ARE LIKELY TO BE PRESENT OR STORED (GARAGES, STORAGE AND UTILITY AREAS, ETC):** Flammable liquids (such as gasoline, solvents, propane (LP) or butane, etc.) or other substances (such as adhesives, etc.), all of which emit flammable vapors, may be improperly stored or used in such areas. The gas water heater ignitor or main burner can ignite such vapors. The resulting flash-back and fire can cause death or serious burns to anyone in the area, as well as property damage.

If installation in such areas is your only option, then the installation must be accomplished in a way that the ignitor and main burner flame are elevated from the floor at least 18 inches. While this may reduce the chances of flammable vapors from a floor spill being ignited, gasoline and other flammable substances should never be stored or used in the same room or area containing a gas water heater or other open flame or spark producing appliance.

Also, the water heater must be located and/or protected so it is not subject to physical damage by a moving vehicle.

**NOTE:** Flammable vapors may be drawn by air currents from other areas of the structure to the appliance.

### ▲WARNING

Propellants of aerosol sprays and volatile compounds, (cleaners, chlorine based chemicals, refrigerants, etc.) in addition to being highly flammable in many cases, will also change to corrosive hydrochloric acid when exposed to the combustion products of the water heater. The results can be hazardous, and also cause product failure.

### ▲WARNING

This water heater must not be installed directly on carpeting. Carpeting must be protected by a metal or wood panel beneath the appliance extending beyond the full width and depth of the appliance by at least 3 inches (76.2mm) in any direction, or if the appliance is installed in an alcove or closet, the entire floor must be covered by the panel. Failure to heed this warning may result in a fire hazard.

### ▲WARNING

Minimum clearances between the water heater and combustible and non-combustible construction are: 0 inches from sides, 0 inches from back, 6 inches from front of jacket to closet door and 12 inches from top of jacket to combustible and non-combustible material. Minimum vent clearance: 0 inches. Provide 24 inches front clearance for servicing and adequate clearance between the jacket top and ceiling for servicing the flue area.

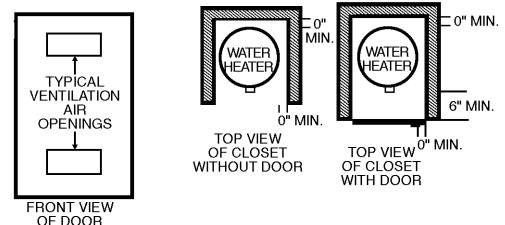

Figure 1

# Locating the New Water Heater (cont'd)

## Facts to Consider About the Location (cont'd)

### ▲WARNING

Do not install in a confined area such a closet, unless you provide ventilation air as shown in the "Locating The New Water Heater" section. Never obstruct the flow of ventilation air. If you have any doubts or questions at all, call your gas company. Failure to provide ventilation air can result in a fire or explosion and can cause DEATH, SERIOUS BODILY INJURY, OR PROPERTY DAMAGE.

### ▲WARNING

If this water heater will be used in beauty shops, barber shops, cleaning establishments, or self-service laundries with dry cleaning equipment, it is imperative that the water heater or water heaters be installed so that combustion and ventilation air be taken from outside these areas. Refer to the "Locating The New Water Heater" section of this manual and also the current edition of the National Fuel Gas Code, ANSI Z223.1, also referred to as NFPA 54 for specifics provided concerning air required.

- The venting system must be installed in a manner which allows inspection of the installation of the venting pipes and joints as well as periodic inspection after installation as required by the National Fuel Gas Code ANSI Z223.1.

### ▲WARNING

Vent termination must not be within 4 feet of any items such as gas meters, gas valves or other gas regulating equipment.

### ▲WARNING

Failure to have required clearances between water heater and combustible material will result in a fire hazard.

## Combustion Air and Exhaust

### ▲WARNING

When determining the installation location for a power direct vent water heater, snow accumulation and drifting should be considered in areas where applicable.

### Venting Through an Outside Wall – Clearances

- 0" clearance for 3" PVC, ABS, or CPVC Schedule 40 piping from combustible surfaces.
- 18" minimum in all directions from any obstruction, such as a wall, that may interfere.
- 12" minimum from the ground and corners, 9" ceiling overhangs. Figure 2.
- The Power Direct Vent outlet terminal shall terminate at least 36" above any forced air inlet located within 10 feet. Figure 3.
- The Power Direct Vent outlet terminal of 50,000 BtuH input models or less shall terminate at least 9" below, 9" horizontally from or 9" above any door, window or gravity air inlet into the building. Figure 3.
- The Power Direct Vent outlet terminal of over 50,000 BtuH input models shall terminate at least 12" below, 12" horizontally from or 12" above any door, window or gravity air inlet into the building. Figure 3.
- 18" minimum from other natural draft (gravity) direct vent, power vent or power direct vent appliance inlet and/or outlet vent(s) when directly above or 135° to either side of center line. Figure 4, page 9.
- 24" minimum from any appliance inlet and/or outlet vents when directly below or 45° to either side of center line. Figure 4, page 9.
- The location selection must provide clearances for servicing and proper operation of the water heater. Figure 5.
- Vent termination must not be within 4 feet of any items such as gas meters, gas valves or other gas regulating equipment.

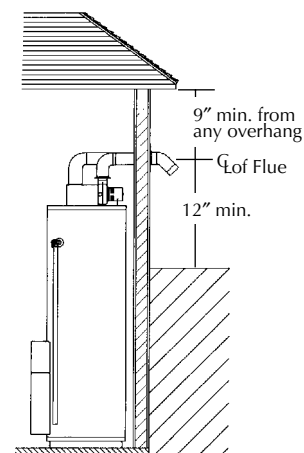

Figure 2

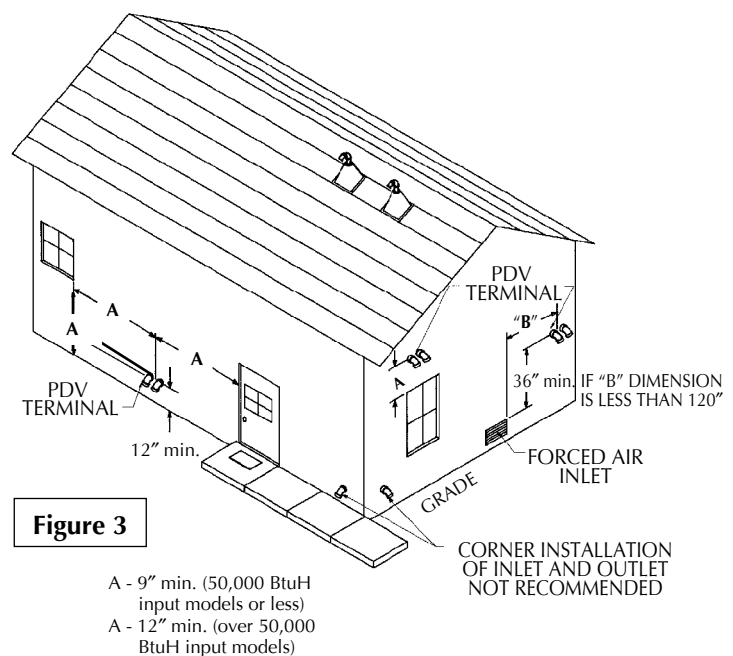

Figure 3

- A - 9" min. (50,000 BtuH input models or less)
- A - 12" min. (over 50,000 BtuH input models)

CORNER INSTALLATION OF INLET AND OUTLET NOT RECOMMENDED



# Locating the New Water Heater (cont'd)

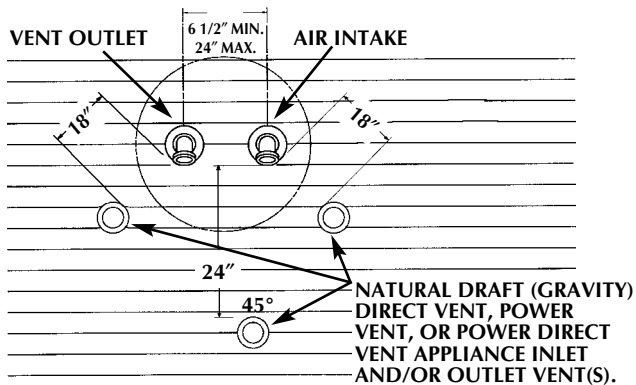

Figure 4

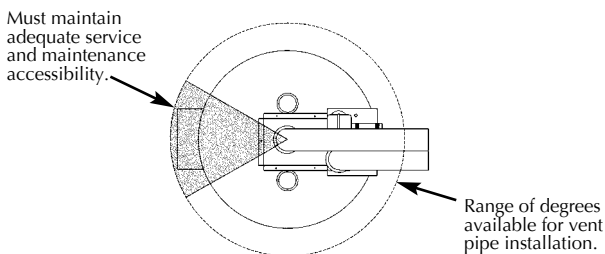

Figure 5

## WIRE FENCE

When the water heater outlet terminal is low enough to be touched accidentally, or is accessible to small children, a wire mesh chain link fence (as shown in Figure 6) may be used. Care should be taken to maintain adequate ventilation around the outlet terminal. If a chain link fence is installed, it must not be used as a storage area for items that may block proper ventilation.

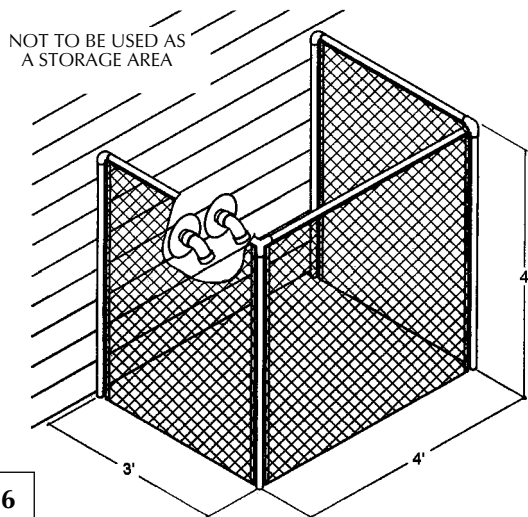

Figure 6

## Venting Through Roof – Clearances

- 0" clearance for 3" PVC, ABS, or CPVC Schedule 40 piping from combustible and noncombustible surfaces.
- The vent exhaust outlet and air inlet terminals shall terminate at least 18 inches above the roof surface. Figure 7.
- The venting system must be installed in a manner which allows inspection of the installation of the venting pipes and joints as well as periodic inspection after installation as required by ANSI Standards.

## VENT PIPE SEPARATION

The inlet and outlet vent pipes must be separated by a minimum distance of 6 1/2 inches to 24 inches maximum.

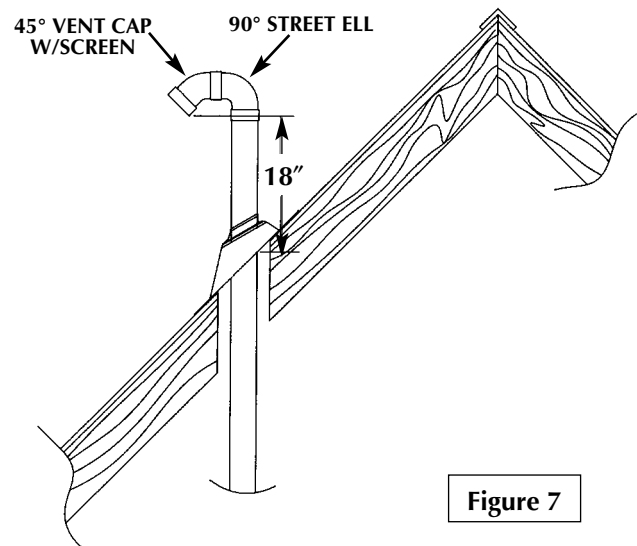

Figure 7

## Air for Ventilation for Appliances Located in Confined Spaces

Air for ventilation should be provided if installed in a confined space. Refer to the National Fuel Gas Code, ANSI Z223.1.

# Installing the New Water Heater

## Water Piping

### ▲WARNING

**HOTTER WATER CAN SCALD:** Water heaters are intended to produce hot water. Water heated to a temperature which will satisfy clothes washing, dish washing, and other sanitizing needs can scald and permanently injure you upon contact. Some people are more likely to be permanently injured by hot water than others. These include the elderly, children, the infirm, or physically/mentally handicapped. If anyone using hot water in your home fits into one of these groups or if there is a local code or state law requiring a certain temperature water at the hot water tap, then you must take special precautions. In addition to using the lowest possible temperature setting that satisfies your hot water needs, some type of tempering device, such as a mixing valve, should be used at the hot water taps used by these people or at the water heater. Mixing valves are available at plumbing supply or hardware stores. Follow manufacturers instructions for installation of the valves. Before changing the factory setting on the thermostat, read the "Temperature Regulation" section in this manual.

This water heater shall not be connected to any heating systems or component(s) used with a non-potable water heating appliance.

If a water heater is installed in a closed water supply system; such as one having a back-flow preventer, check valve, water meter with a check valve, etc. in the cold water supply; means shall be provided to control thermal expansion. Contact the water supplier or plumbing contractor on how to control this situation.

**NOTE:** To protect against untimely corrosion of hot and cold water fittings, it is strongly recommended that dielectric unions or couplings be installed on this water heater when connected to copper pipe.

The illustration shows the attachment of the water piping to the water heater. The water heater is equipped with  $\frac{3}{4}$  inch water connections.

**NOTE:** If using copper tubing, solder tubing to an adapter before attaching the adapter to the cold water inlet connection. Do not solder the cold water supply line directly to the cold water inlet or it will harm the dip tube.

**NOTE:** This water heater is insulated to minimize heat loss from the tank. Further reduction in heat loss can be accomplished by insulating the hot water lines from the water heater.

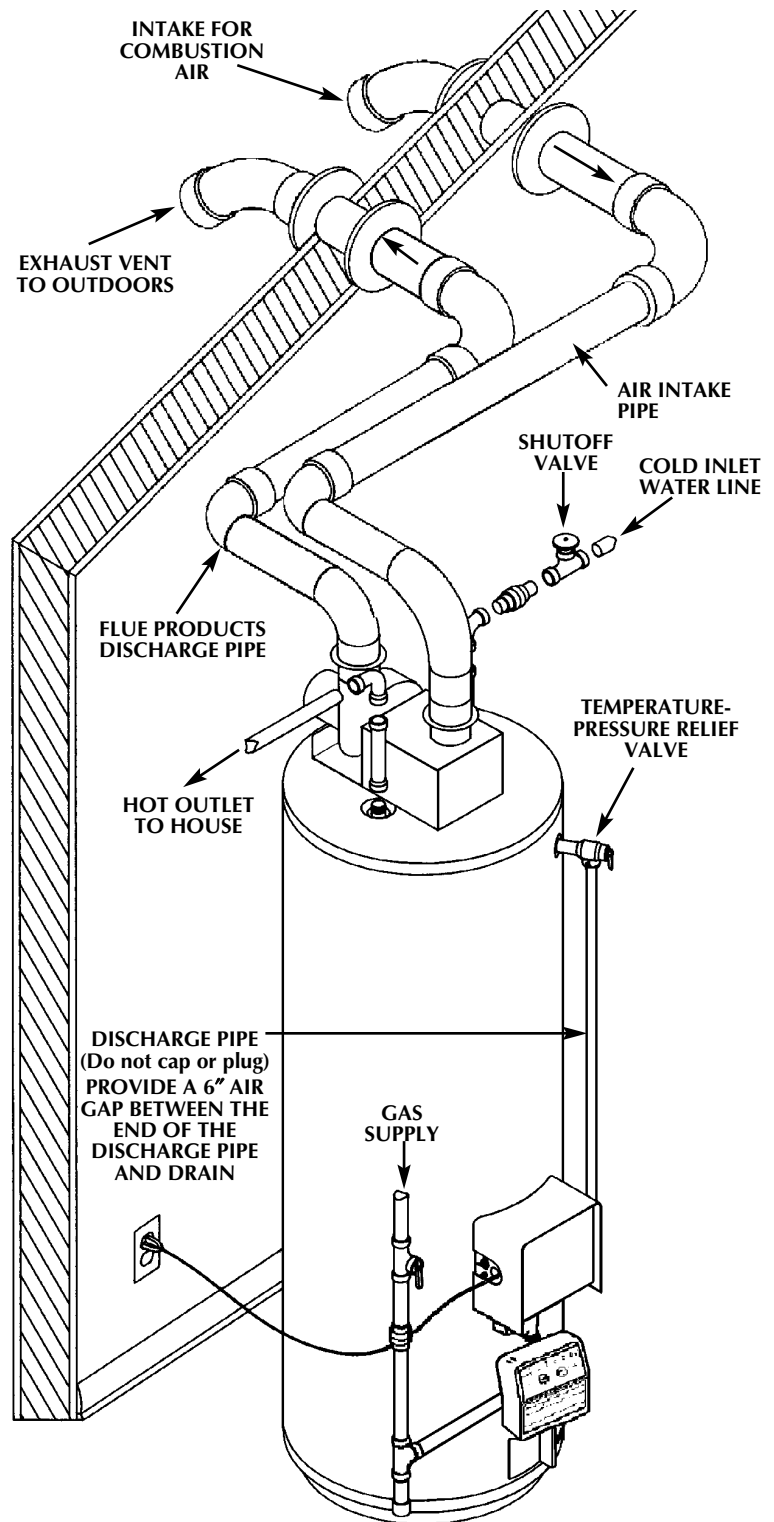

# Installing the New Water Heater (cont'd)

## Temperature-Pressure Relief Valve

### ▲WARNING

At the time of manufacture this water heater was provided with a combination temperature-pressure relief valve certified by a nationally recognized testing laboratory that maintains periodic inspection of production of listed equipment or materials, as meeting the requirements for Relief Valves and Automatic Gas Shutoff Devices for Hot Water Supply Systems, and the current edition of ANSI Z21.22 and the code requirements of ASME. If replaced, the valve must meet the requirements of local codes, but not less than a combination temperature and pressure relief valve certified as meeting the requirements for Relief Valves and Automatic Gas Shutoff Devices for Hot Water Supply Systems, ANSI Z21.22 by a nationally recognized testing laboratory that maintains periodic inspection of production of listed equipment or materials.

The valve must be marked with a maximum set pressure not to exceed the marked hydrostatic working pressure of the water heater (150 lbs./sq. in.) and a discharge capacity not less than the water heater input rate as shown on the model rating plate. (Electric heaters - watts divided by 1000 x 3412) equal BTU/Hr. rate.

Your local jurisdictional authority, while mandating the use of a temperature-pressure relief valve complying with ANSI Z21.22 and ASME, may require a valve model different from the one furnished with the water heater.

Compliance with such local requirements must be satisfied by the installer or end user of the water heater with a locally prescribed temperature-pressure relief valve installed in the designated opening in the water heater in place of the factory furnished valve.

For safe operation of the water heater, the relief valve must not be removed from its designated opening or plugged.

The temperature-pressure relief valve must be installed directly into the fitting of the water heater designated for the relief valve. Position the valve downward and provide tubing so that any discharge will exit only within 6 inches above, or at any distance below the structural floor. Be certain that no contact is made with any live electrical part. The discharge opening must not be blocked or reduced in size under any circumstances. Excessive length, over 30 feet, or use of more than four elbows can cause restriction and reduce the discharge capacity of the valve.

No valve or other obstruction is to be placed between the relief valve and the tank. Do not connect tubing directly to discharge drain unless a 6" air gap is provided. To prevent bodily injury, hazard to life, or property damage, the relief valve must be allowed to discharge water in quantities should circumstances demand. If the discharge pipe is not connected to a drain or other suitable means, the water flow may cause property damage.

The discharge pipe:

- Must not be smaller in size than the outlet pipe size of the valve, or have any reducing couplings or other restriction.
- Must not be plugged or blocked.
- Must be of material listed for hot water distribution.
- Must be installed so as to allow complete drainage of both the temperature-pressure relief valve, and the discharge pipe.
- Must terminate at an adequate drain.
- Must not have any valve between the relief valve and tank.

### ▲WARNING

The temperature-pressure relief valve must be manually operated at least once a year. Caution should be taken to ensure that (1) no one is in front of or around the outlet of the temperature-pressure relief valve discharge line, and (2) the water manually discharged will not cause any bodily injury or property damage because the water may be extremely hot.

If after manually operating the valve, it fails to completely reset and continues to release water, immediately close the cold water inlet to the water heater, follow the draining instructions, and replace the temperature-pressure relief valve with a new one.

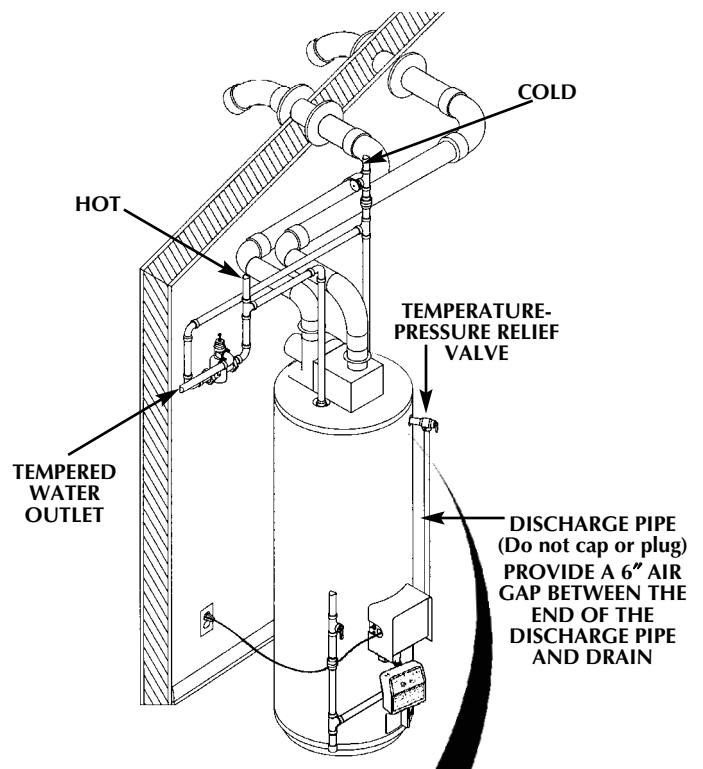

### Relief Valve Opening

"THIS WATER HEATER IS PROVIDED WITH A COMBINATION TEMPERATURE-PRESSURE RELIEF VALVE. FOR SAFE OPERATION OF THE WATER HEATER, THE RELIEF VALVE(S) MUST NOT BE REMOVED FROM ITS DESIGNATED POINT OF INSTALLATION OR PLUGGED."

YOUR LOCAL JURISDICTIONAL AUTHORITY, WHILE MANDATING THE USE OF A TEMPERATURE-PRESSURE RELIEF VALVE COMPLYING WITH ANSI Z21.22 AND ASME, MAY REQUIRE A VALVE MODEL DIFFERENT FROM THE ONE FURNISHED WITH THE WATER HEATER.

COMPLIANCE WITH SUCH LOCAL REQUIREMENTS MUST BE SATISFIED BY THE INSTALLER OR END USER OF THE WATER HEATER WITH LOCALLY PRESCRIBED TEMPERATURE-PRESSURE RELIEF VALVE INSTALLED IN THE DESIGNATED OPENING IN THE WATER HEATER.

SEE MANUAL HEADING—"TEMPERATURE-PRESSURE RELIEF VALVES" FOR INSTALLATION AND MAINTENANCE OF RELIEF VALVE. DISCHARGE LINE AND OTHER SAFETY PRECAUTIONS.

# Installing the New Water Heater (cont'd)

## Filling the Water Heater

### ▲CAUTION

Never use this water heater unless it is completely filled with water. To prevent damage to the tank, the tank must be filled with water. Water must flow from the hot water faucet before turning "ON" gas to the water heater.

To fill the water heater with water:

1. Close the water heater drain valve by turning the handle to the right (clockwise). The drain valve is on the lower front of the water heater.
2. Open the cold water supply valve to the water heater.  
**NOTE: The cold water supply valve must be left open when the water heater is in use.**
3. To insure complete filling of the tank, allow air to exit by opening the nearest hot water faucet. Allow water to run until a constant flow is obtained. This will let air out of the water heater and the piping.
4. Check all new water piping for leaks. Repair as needed.

## Wiring

The water heater comes equipped with a 7 foot power cord which can be used to connect to a 110/120 volt power source if, (1) local codes allow, and (2) there is a three prong receptacle available. **This unit must have a grounded outlet to operate.**

You must provide all wiring, (1) to a receptacle or, (2) between the water heater and junction box when the power cord is not used.

### ▲WARNING

This appliance must be grounded for safety and to insure proper operation. Failure to do so could result in DEATH, SERIOUS BODILY INJURY OR PROPERTY DAMAGE.

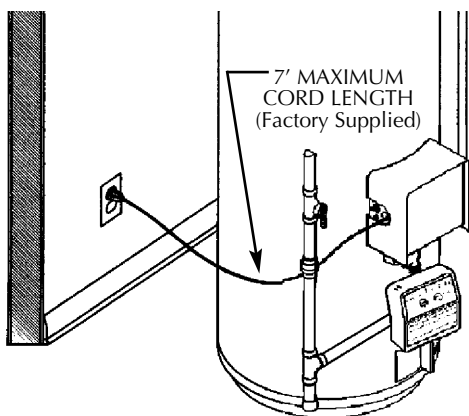

### ▲WARNING

Do not use an extension cord. If there is not a suitable receptacle and/or local codes prohibit use of a power cord, field wiring must be provided.

You must provide all wiring of the proper size outside of the water heater. You must obey local codes and electric company requirements when you install this wiring.

If you are not familiar with electric codes and practices, or if you have any doubt in your ability to connect the wiring to this water heater, obtain the service of a competent electrician. Contact a local electrical contractor and/or the local electric utility.

### ▲WARNING

**WATER HEATERS EQUIPPED FOR ONE TYPE VOLTAGE ONLY: This water heater is equipped for 110/120 volts only. DO NOT USE THIS WATER HEATER WITH ANY VOLTAGE OTHER THAN THE ONE SHOWN ABOVE. Failure to use the correct voltage can cause problems which can result in DEATH, SERIOUS BODILY INJURY OR PROPERTY DAMAGE. If you have any questions or doubts consult your electric company.**

### ▲CAUTION

If wiring from the fuse box or circuit breaker box was aluminum for the old water heater, replace it with copper wire. If you wish to reuse the existing aluminum wire, have the connection at the water heater made by a competent electrician. Contact a local electrical contractor and/or the local electric utility.

## OPTIONAL Field Installed Wiring

1. Provide a way to easily shut off the electric power when working on the water heater. This could be with a circuit breaker or fuse block in the entrance box or a separate disconnect switch.
2. Install and connect a circuit directly from the main fuse or circuit breaker box. This circuit must be the right size and have its own fuse or circuit breaker.

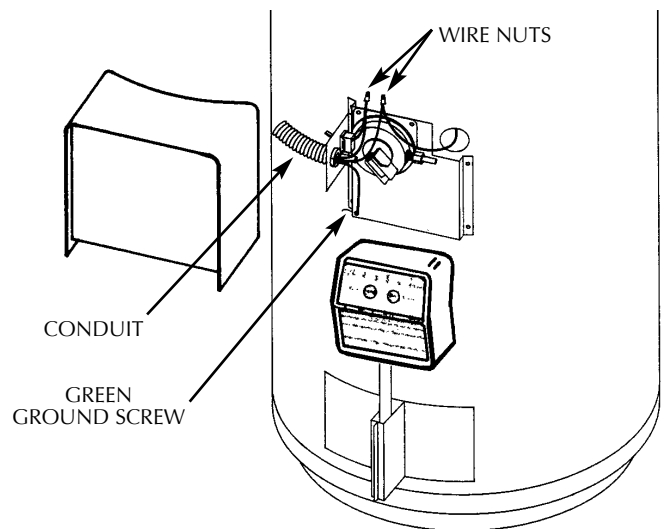

3. A standard 1/2" conduit opening has been made in the water heater junction box for the conduit connection.
4. Use wire nuts and connect the power supply wiring to the wires inside the water heater's junction box.

# Installing the New Water Heater (cont'd)

- The water heater must be electrically "grounded" by the installer. The unit will not operate unless it is properly grounded. For complete grounding details and all allowable exceptions, refer to local codes or in the

absence of local codes, with the National Electrical Code, ANSI/NFPA 70 (current edition).

- Replace the wiring junction cover using the screws provided.

## Wiring Diagram

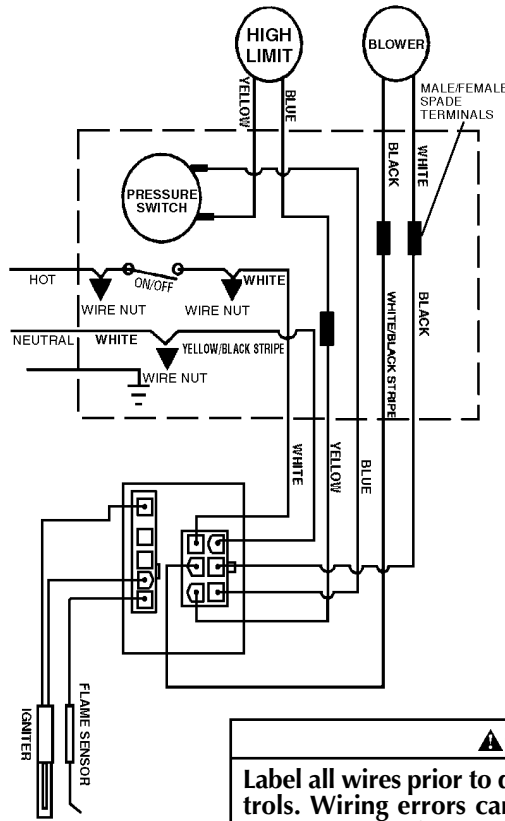
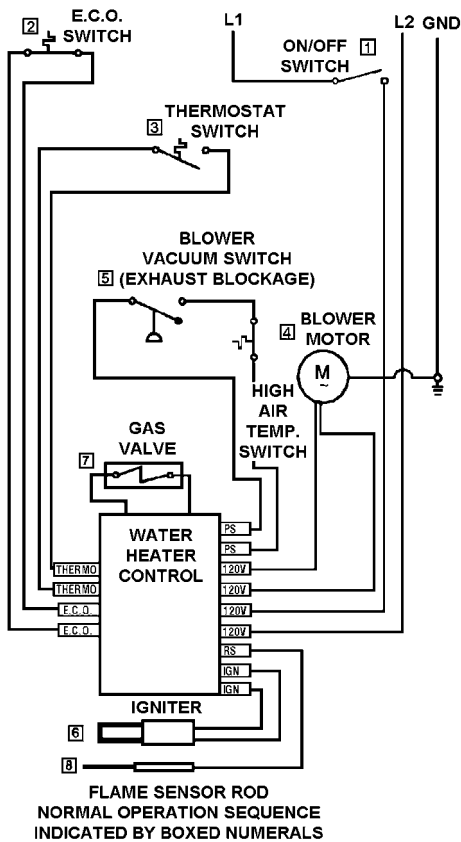

**CAUTION**  
Label all wires prior to disconnection when servicing controls. Wiring errors can cause improper and dangerous operation. Verify proper operation after servicing.

**WARNING**  
The vent pipe from the water heater must be 3" diameter vent pipe and must slope upward 1/8 inch per five linear feet.

## Venting

**WARNING**  
To insure proper venting of this gas-fired water heater, the correct vent pipe diameter must be utilized. Any additions of other gas appliances on vent with this water heater will adversely affect the operation of the water heater.

**WARNING**  
The vent outlet must connect to the water heater exhaust outlet. The vent inlet piping must connect to the water heater air inlet. Both the water heater connections are clearly marked. Failure to read this instruction can result in DEATH, SERIOUS BODILY INJURY, OR PROPERTY DAMAGE.

**WARNING**  
Obstructed or deteriorated vent systems may present serious health risk or asphyxiation.

All vent gases must be completely vented to the outdoors of the structure (dwelling).

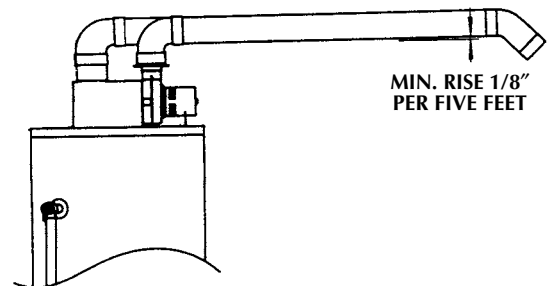

**WARNING**  
Failure to have required clearances between water heater and combustible material will result in a fire hazard.

# Installing the New Water Heater (cont'd)

## Venting (cont'd)

### ▲WARNING

Be sure vent pipe is properly connected to prevent escape of dangerous flue gases which could cause deadly asphyxiation.

### ▲WARNING

Chemical vapor corrosion of the flue and vent system may occur if air for combustion contains certain chemical vapors. Spray can propellants, cleaning solvents, refrigerator and air conditioner refrigerants, swimming pool chemicals, calcium and sodium chloride, waxes, bleach and process chemicals are typical compounds which are potentially corrosive.

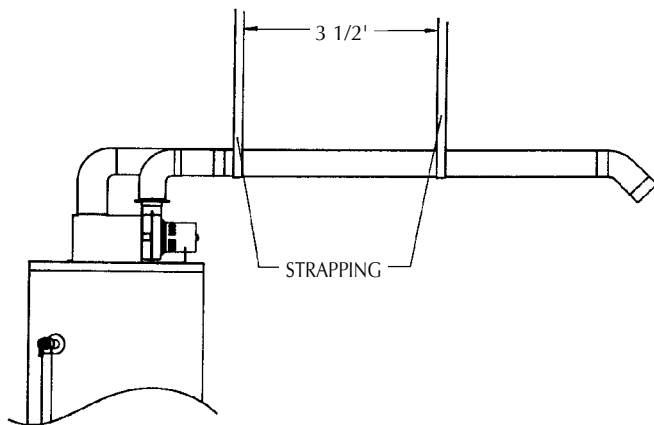

Horizontal runs must be securely supported at 3 1/2 foot intervals and vertical runs supported at 5 foot intervals.

### VENTING THROUGH AN OUTSIDE WALL

#### A. ALL 75 GALLON MODELS AND 50 GALLON 65,000 BTU/HR MODELS

In the carton is supplied:

1. Two 3" inlet and outlet PVC Schedule 40 - 45° vent caps.
2. A 3" ABS Schedule 40 - 90 street ell; used to connect the **outlet** vent pipe to the water heater when the **outlet** vent pipe is to be turned horizontally directly off the blower.
3. A 5' section of 3" ABS Schedule 40 **outlet** vent pipe (more may be required and must be supplied locally).

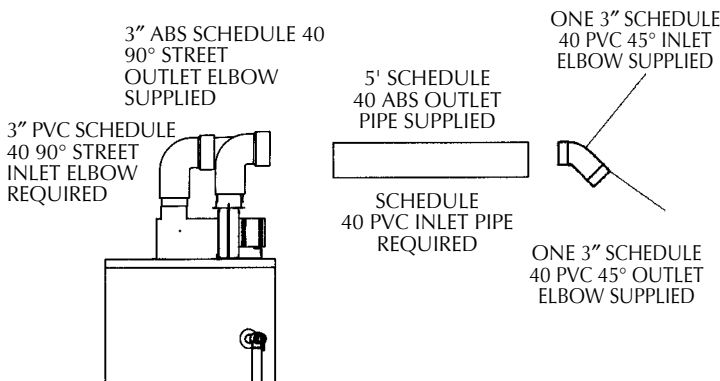

1. The water heater requires its own (separate) venting system.
2. **Only** 3" ABS Schedule 40 piping and fittings are acceptable materials on the first five feet of the outlet vent system.
3. 3" PCV, ABS, or CPVC Schedule 40 piping and fittings are acceptable materials for the inlet vent system and for the outlet vent system after the first five feet.
4. It cannot be connected to existing vent piping or chimney.
5. When venting through an outside wall, the vents must terminate horizontally to the outdoors.

#### B. ALL 40 AND 50 GALLON 40,000 BTU/HR MODELS

In the carton is supplied:

1. Two 3" inlet and outlet PVC Schedule 40 - 45° vent caps.
- All other piping must be supplied by the supplier.

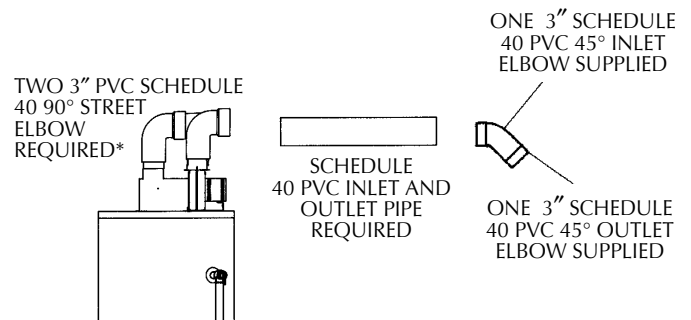

\* If making an immediate horizontal run of vent off the blower, two 3" PVC or ABS schedule 40 street elbows are required

1. The water heater requires its own (separate) venting system.
2. 3" PVC, ABS, or CPVC Schedule 40 piping and fittings are acceptable materials for the vent system on all 40 and 50 gallon models.
3. It cannot be connected to existing vent piping or chimney.
4. When venting through an outside wall, the vents must terminate horizontally to the outdoors.

# Installing the New Water Heater (cont'd)

## VENTING SYSTEM EXAMPLE INSTALLATIONS FOR ALL MODELS

The vent piping **cannot** under any circumstances be run downhill.

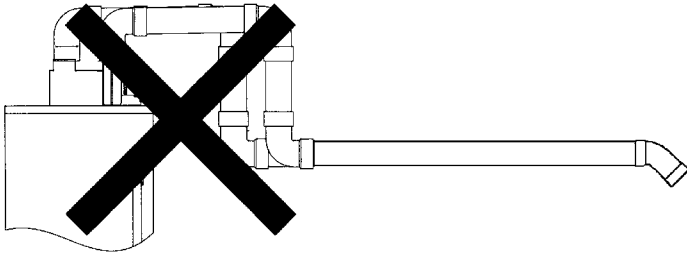

The vent piping can be installed as follows:

1. Horizontal runs require a minimum 1/8" rise per five feet.

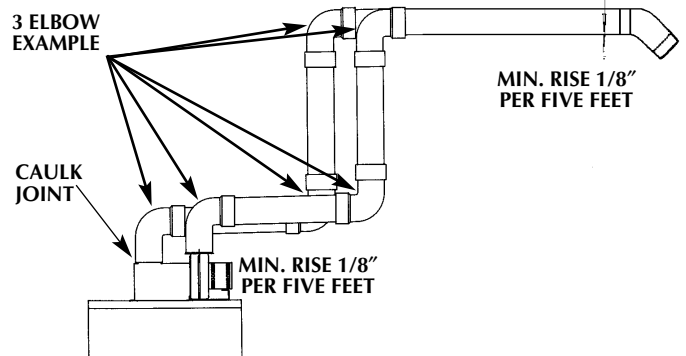

2. The total vertical and horizontal vent runs cannot exceed the maximum length with the number of 90° elbows as specified in the table below. If more elbows are required, the venting distance must be reduced 5 feet for every 90° elbow:

3" DIA. VENTS MAX. LENGTH (FT.)	NUMBER OF 90° DEG. ELBOWS*
45	1
40	2
35	3

\*NOTE: Two 45° elbows are equivalent to one 90° elbow. One 90° elbow equals 5 feet of equivalent vent length.

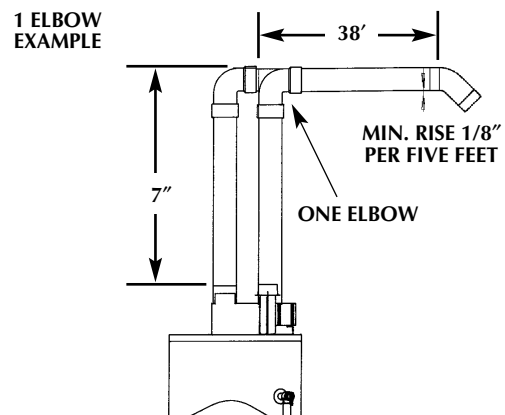
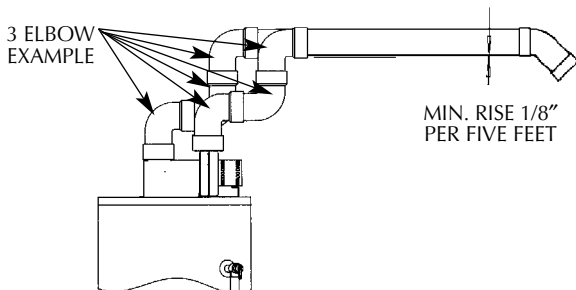
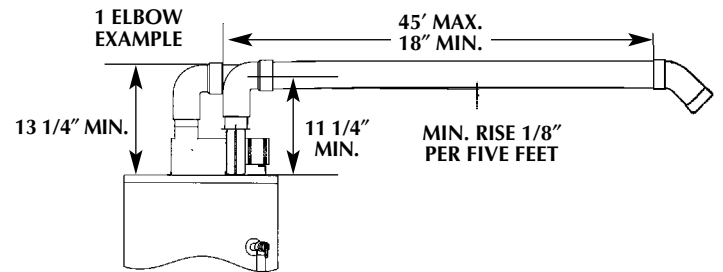
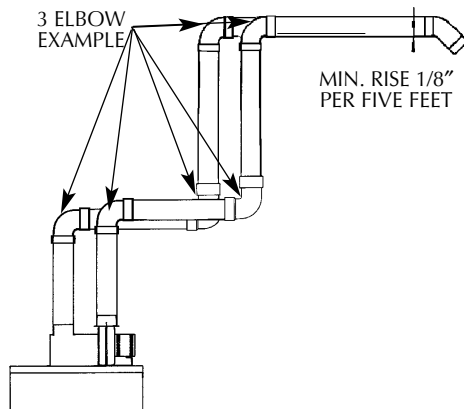

3. Minimum vent length for all models is 18 inches.

# Installing the New Water Heater (cont'd)

## Cementing PVC, ABS OR CPVC Pipe and Fittings

Read and observe all safety information printed on primer, cleaner, and cement containers.

### ▲DANGER

Primer, cleaner, and cements are extremely flammable. They are harmful or fatal if swallowed. The vapors are harmful. They may irritate eyes and skin and can be absorbed through the skin.

### ▲PRECAUTIONS

Always store primers, cleaner, and cements in cool, dry, well ventilated places. Do not store them near heat, sparks, or flames. Keep containers closed. Use them in well ventilated areas. Wear impervious clothing while handling. Do not smoke, eat, or drink while handling. Wash thoroughly after handling and before eating. Wear eye protection when handling. If swallowed, drink water, do not induce vomiting, and call a physician or poison control center immediately. If inhaled, get fresh air and seek medical attention if ill feelings persist. In case of eye and skin contact, immediately flush with plenty of water for 15 minutes and seek medical attention if irritation persists. **KEEP OUT OF REACH OF CHILDREN.**

All primers, cleaners, and cements must meet all local codes and applicable standards of the American Society For Testing Materials Standards.

Before using primers, cleaners, and cements, stir or shake, making sure contents are liquid. Do not use if found to be lumpy or jelly-like.

1. Cut pipe ends squarely removing all burrs and dirt.
2. Dry fit pipe and fittings to be connected for proper fit.
3. Clean pipe and fitting with a primer/cleaner.
4. Apply a thin coat of cement to fitting, avoiding puddling inside.
5. Apply a liberal coat of cement to pipe leaving no voids.
6. QUICKLY assemble parts while cement is fluid! If you wait too long, re-coat pipes.
7. Push pipe completely into socket of fitting, turning as it goes until it bottoms.
8. Hold pipe and fitting together for 30 seconds. Then carefully clean off excess with a cloth. Allow connections a sufficient time to cure before disturbing.
9. Remember that vent pipes must be adequately and securely supported.

APPROXIMATE SETTING TIME FOR 2 1/2" TO 4" PIPE JOINTS

	MOVEMENT OF JOINT	COMPLETE SET
90°F to 150°F	3/4 hr.	8 hrs.
50°F to 90°F	1 hr.	15 hrs.
0°F to 50°F	1 1/3 hr.	18 hrs.

## VENT PIPE SEPARATION

The inlet and outlet vent pipes must be separated by a minimum distance of 6 1/2 inches up to 24 inches maximum.

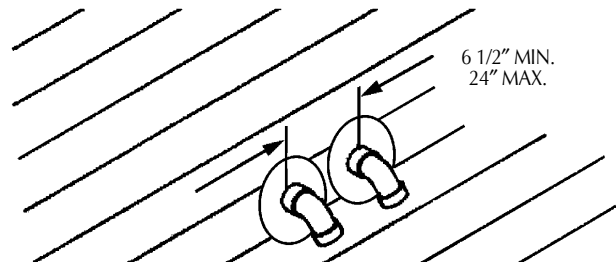

## CUTTING OPENINGS THROUGH AN OUTSIDE WALL AND COLLAR INSTALLATION

After reading the manual and you have determined the location of the opening in the wall, (using the drawing below), cut one 3 1/2" diameter hole for the **inlet** vent piping and one 3 1/2" diameter hole for the **outlet** vent piping through an exterior wall.

**NOTE:** When determining location of the openings in the outside wall allow for the 1/8" rise per five feet that has taken place in the horizontal run.

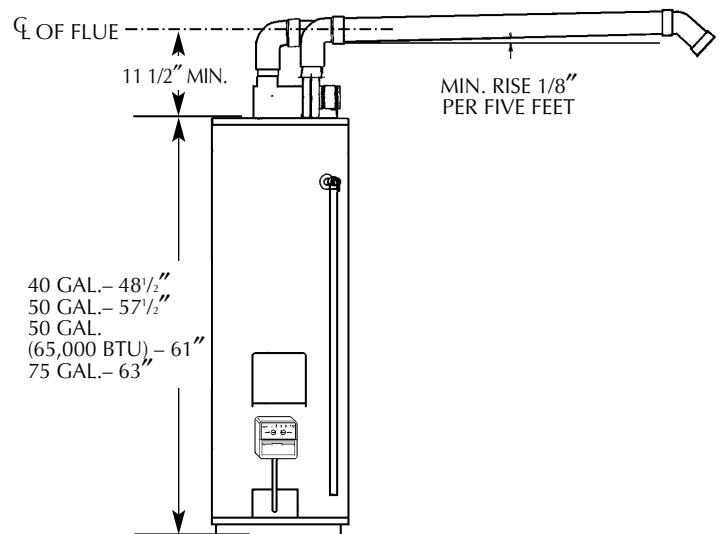

The 3" PVC, ABS or CPVC Schedule 40 vent pipe can be run from the water heater through the wall or from the wall to the water heater, whichever is most convenient. The vent pipe must extend a minimum of 1 1/2" through the exterior wall. Extending the vent cap as far as possible from the surface of the exterior wall will help minimize discoloration of the wall. Note that the inside flue mounting adaptors must be slipped over the vent piping before locating the pipe through the wall. Before securing the inside and outside collars to the wall, use a silicone sealer between pipe and opening to insure a water and air tight seal.



# Installing the New Water Heater (cont'd)

## Venting (cont'd)

INSTALLATION SHOWING USE OF PVC, ABS OR CPVC PIPE FOR INLET AND OUTLET VENT PIPING:

Inlet piping through any type wall.

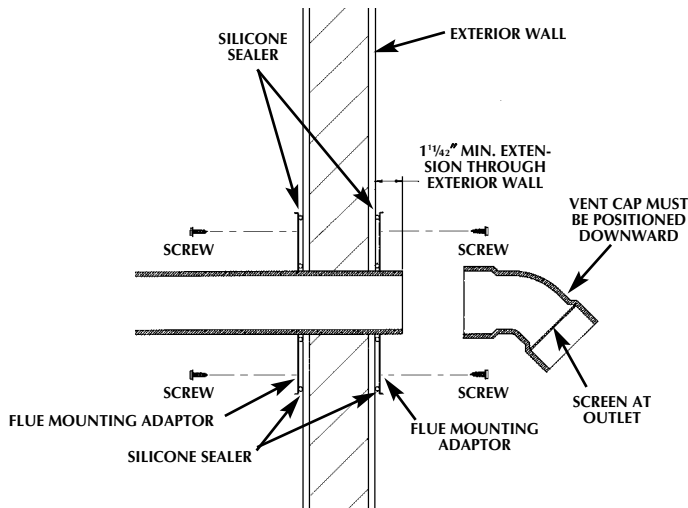

### CONNECTING VENT TO BLOWER

1. If making an immediate horizontal run of vent off the blower, one 3" PVC **inlet** and one 3" PVC (ABS for 75 Gal. Models and 50 Gal. 65,000 Btu/Hr Models) **outlet** Schedule 40 street elbows are required. Place the elbow in the required direction on the blower and using 3 sheet metal screws, attach the elbow.

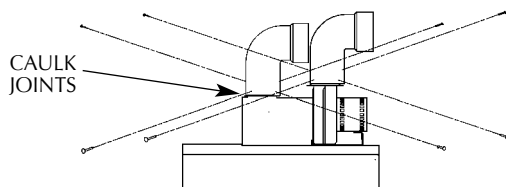

2. If there is to be a vertical run of vent from the blower, the 3" PVC inlet and the 3" PVC (ABS for 75 Gal. Models and 50 Gal. 65,000 Btu/Hr Models) outlet pipes must be attached to the blower and venting hood, using 6 sheet metal screws.

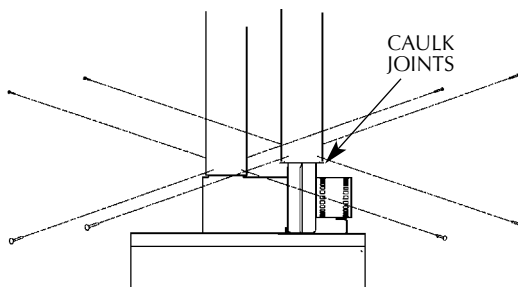

INSTALLATION SHOWING USE OF (OPTIONAL) DELUXE HORIZONTAL VENT KIT:

Typical installation.

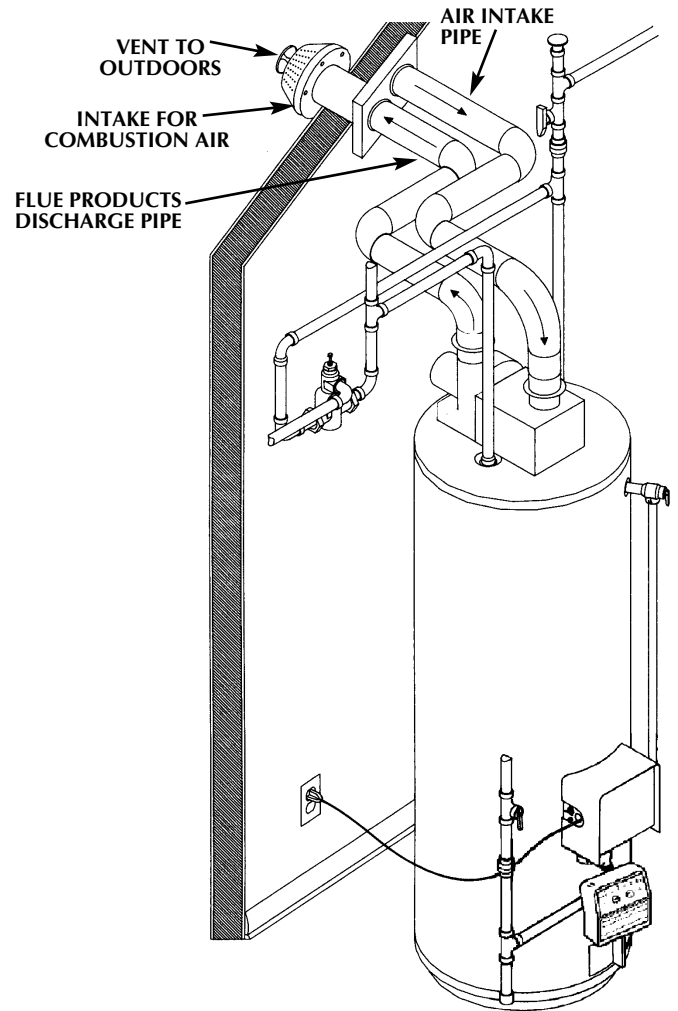

If this concentric flue, through the wall type of venting system is preferred, the vent kit can be ordered from the Service Parts Dept. under kit #9002749. See also pages 34 to 37. Installation instructions are provided with the kit.

### VENTING THROUGH A ROOF

Two 3" inlet and outlet PVC Schedule 40 45° vent caps are supplied.

A 5' section of 3" ABS Schedule 40 **outlet** vent pipe (75 Gal. Models and 50 Gal. 65,000 Btu/Hr Models only) is supplied. (More may be required and must be supplied locally).

1. The water heater requires its own (separate) venting system.

# Installing the New Water Heater (cont'd)

## VENTING THROUGH A ROOF (CONT'D)

2. Only 3" ABS Schedule 40 piping and fittings are acceptable materials on the first five feet of the outlet vent system of 75 Gal. Models and 50 Gal. 65,000 Btu/Hr Models only.
3. 3" PVC, ABS, or CPVC Schedule 40 piping and fittings are acceptable materials for the inlet vent system and for the outlet vent system (after the first five feet for 75 Gal. Models and 50 Gal. 65,000 Btu/Hr Models only).
4. It cannot be connected to existing vent piping or chimney.
5. It must terminate vertically to the outdoors.
6. The total vertical and horizontal vent runs cannot exceed the maximum length with a maximum number of 90° elbows as specified in the table below. If more elbows are required, the venting distance must be reduced 5 feet for every 90° elbow.

3" DIA. VENTS MAX. LENGTH (FT.)	NUMBER OF 90° DEG. ELBOWS*
45	1
40	2
35	3

\*NOTE: Two 45° elbows are equivalent to one 90° elbow. One 90° elbow equals 5 feet of equivalent vent length.

## VENT PIPE SEPARATION

The inlet and outlet vent pipes must be separated by a minimum distance of 6 1/2 inches up to 24 inches maximum.

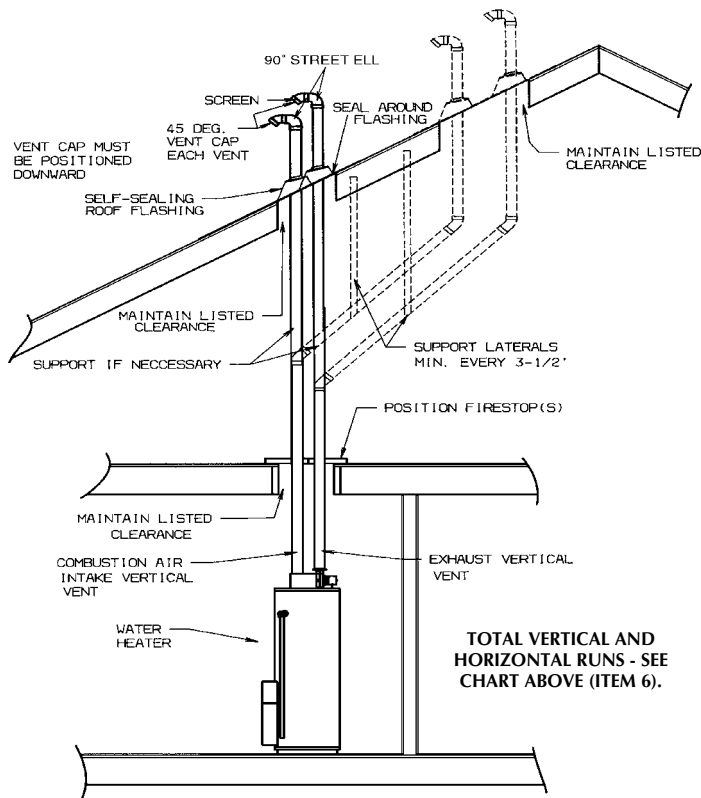

## Gas Piping

### ▲WARNING

Make sure the gas supplied is the same type listed on the model rating plate. The inlet gas pressure must not exceed 10.5 in. water column (2.6kPa) for natural gas or 13 in. water column (3.2 kPa) for propane (L.P.) gas. The minimum inlet gas pressure listed on the rating plate is for the purpose of input adjustment.

### ▲WARNING

If the gas control valve is subjected to pressure exceeding 1/2 pound per square inch (3.5kPa), the damage to the gas control valve could result in a fire or explosion from leaking gas.

### ▲WARNING

If the main gas line shutoff serving all gas appliances is used, also turn "OFF" the gas at each appliance. Leave all gas appliances turned "OFF" until the water heater installation is complete.

A gas line of sufficient size must be run to the water heater. Consult the current edition of National Fuel Gas Code ANSI Z223.1, also referred to as NFPA 54 and the gas company concerning pipe size.

There must be:

- A readily accessible manual shut off valve in the gas supply line serving the water heater, and
- A drip leg (sediment trap) ahead of the gas control valve to help prevent dirt and foreign materials from entering the gas control valve.
- A flexible gas connector or a ground joint union between the shutoff valve and control valve to permit servicing of the unit.

Be sure to check all the gas piping for leaks before lighting the water heater. Use a soapy water solution, not a match or open flame. Rinse off soapy solution and wipe dry.

When installed at elevations above 2,000 feet, input ratings should be reduced at the rate of 4 percent for each 1,000 feet above sea level which requires replacement of the burner orifice in accordance with the National Fuel Gas Code ANSI Z223.1 / NFPA 54. Contact your local gas utility for further information.

### ▲WARNING

Failure to replace the orifice could result in improper and inefficient operation of the appliance, producing carbon monoxide gas in excess of safe limits, which could result in serious injury or death. Contact your gas supplier for any specific changes which may be required in your area.

# Installing the New Water Heater (cont'd)

## ▲WARNING

The appliance and its individual shutoff valve must be disconnected from the gas supply piping system during any pressure testing of that system at test pressures in excess of 1/2 pound per square inch (3.5kPa). The appliance must be isolated from the gas supply piping system by closing its individual manual shutoff valve during any pressure testing of the gas supply piping system at test pressures equal to or less than 1/2 pound per square inch (3.5kPa).

## ▲WARNING

The appliance and its gas connection must be leak tested before placing the appliance in operation.

## ▲WARNING

Use pipe joint compound or teflon tape marked as being resistant to the action of petroleum [Propane (L.P.)] gases.

Connecting the gas piping to the gas control valve of the water heater can be accomplished by either of the two methods shown.

### SEDIMENT TRAP

A sediment trap shall be installed as close to the inlet of the water heater as practical at the time of water heater installation. The sediment trap shall be either a tee fitting with a capped nipple in the bottom outlet or other device recognized as an effective sediment trap. If a tee fitting is used, it shall be installed in conformance with one of the methods of installation shown.

## ▲WARNING

Contaminants in the gas lines may cause improper operation of the gas control valve that may result in fire or explosion. Before attaching the gas line be sure that all gas pipe is clean on the inside. To trap any dirt or foreign material in the gas supply line, a drip leg (sometimes called a sediment trap) must be incorporated in the piping. The drip leg must be readily accessible. Install in accordance with the "Gas Piping" section. Refer to the current edition of the National Fuel Gas Code, ANSI Z223.1, also referred to as NFPA 54.

### GAS PIPING WITH FLEXIBLE CONNECTOR

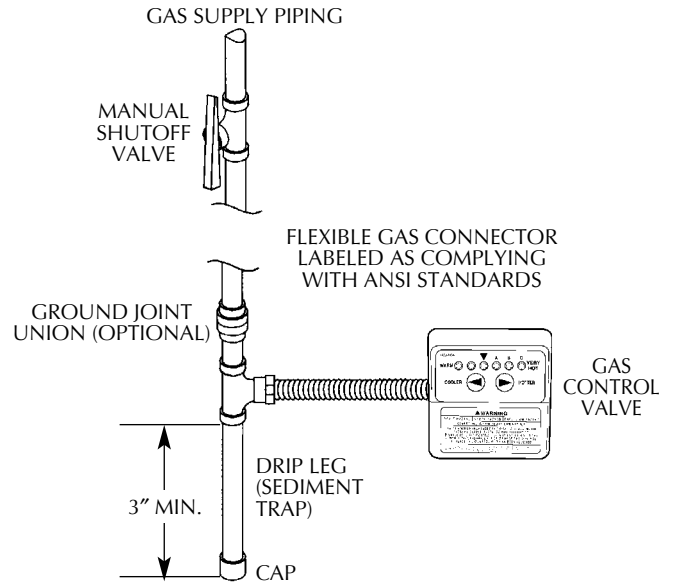

### GAS PIPING WITH ALL BLACK IRON PIPE TO GAS CONTROL

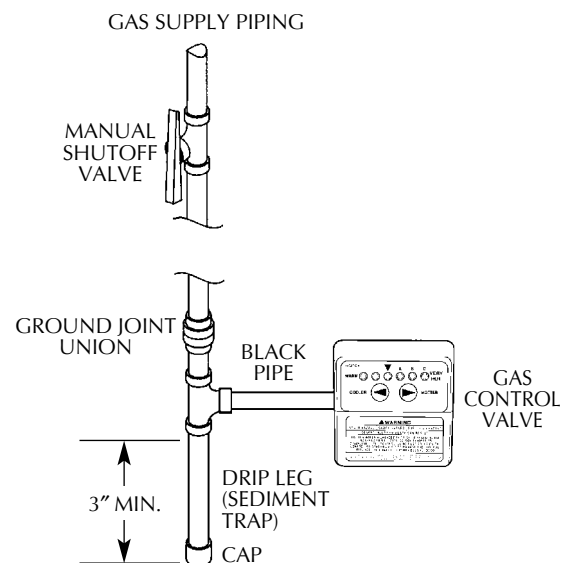

# Installing the New Water Heater (cont'd)

## Installation Checklist

### BEFORE OPERATING THE WATER HEATER:

1. Check the gas line for leaks.
  - a. Use a soapy water solution. DO NOT test for gas leaks using a match or open flame.
  - b. Brush the soapy water solution on all gas pipes, joints and fittings.
  - c. Check for bubbling soap. This means you have a leak. Turn "OFF" gas and make the necessary repairs.
  - d. Recheck for leaks.
  - e. Rinse off soapy solution and wipe dry.
2. Is the new temperature-pressure relief valve properly installed and piped to an adequate drain? See "Temperature-Pressure Relief Valve" section.
3. Are the cold and hot water lines connected to the water heater correctly? See "Water Piping" instructions in the "Installing the New Water Heater" section.

4. Is the water heater completely filled with water? See "Filling the Water Heater" instructions in the "Installing the New Water Heater" section.
5. Will a water leak damage anything? See the "Locating the New Water Heater" section.
6. Is there proper clearance between the water heater and anything that might catch fire? See the "Locating the New Water Heater" section.
7. Do you have adequate ventilation so that the water heater will operate properly? See "Combustion Air and Ventilation" in the "Locating the New Water Heater" section.
8. Is the vent piping properly secured? See "Venting" instructions in the "Installing the New Water Heater" section.
9. Is there proper clearance between the vent pipe and anything that might catch fire? See "Venting" instructions in the "Installing the New Water Heater" section.
10. Is the vent pipe properly sloped and does the vent terminate outdoors? See "Venting" instructions in the "Installing the New Water Heater" section.
11. Do you need to call your gas company to check the gas pipe and its hookup?

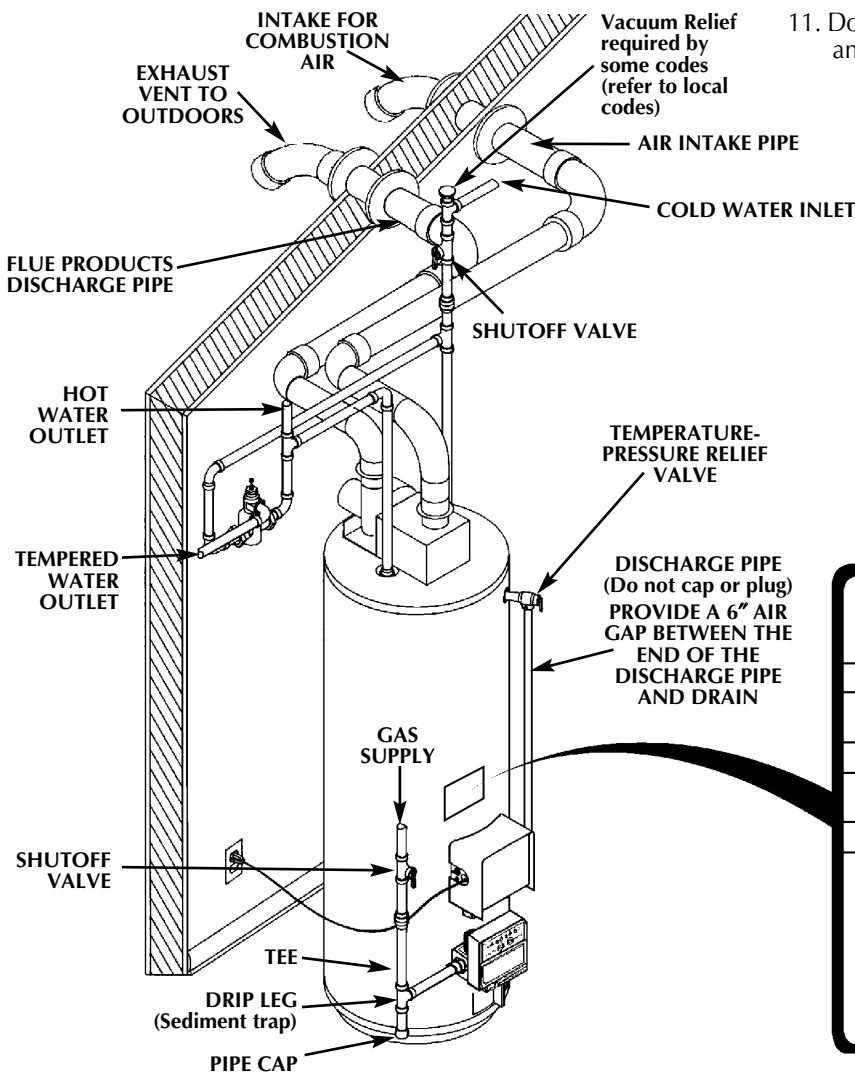

SUITABLE FOR WATER (POTABLE) HEATING AND SPACE HEATING			
MODEL NUMBER		CAPACITY	
		U.S. GAL.	
EQUIPPED FOR	INPUT	RECOVERY	SERIAL NUMBER
GAS	BTU/HR	GAL./HR.	
MAXIMUM HYDROSTATIC WORKING PRESSURE	MAX. INLET	GAS PRESSURE IN W.C. MIN. INLET PRESSURE	MANIFOLD
150			
P.S.I.	W.C.	W.C.	W.C.
<b>AUTOMATIC STORAGE WATER HEATER FOR DIRECT VENT INSTALLATION ELECTRICAL RATING: VOLTS 115/HZ60/AMPS 2</b>			

MODEL RATING PLATE

# Operating

This water heater is equipped with an electrically operated venting system and electronic control. For the burner to come on, the water heater thermostat must call for heat. Then the system will begin sequencing, each section proving itself before gas is allowed to flow to the burner.

## BEFORE THE WATER HEATER WILL OPERATE:

1. The control system must be connected to a grounded 110/120 volt power supply. The control system has an overall rating of 2 amps. The water heater must be securely and adequately grounded in accordance with local codes and with the current edition of the National Electrical Code ANSI/NFPA 70.
2. The ON/OFF toggle switch, located on the control box above the thermostat must be in the "ON" position for the electrical control system to operate allowing the gas portion to operate (ignite burner).
3. The venting manual reset switch must be in the closed position. See "Venting Manual Reset Switch" in the "For Your Information" section.
4. There is a non-resettable hi-limit switch in the thermostat, which must be good (closed) for the thermostat to be operated. See "High Temperature Shut Off System" in the "For Your Information" section.

## OPERATION

When the thermostat calls for heat, gas is allowed to flow to a (N/O) pressure switch closing it. An electrical circuit is then made to the blower, turning it on. When the blower has achieved sufficient venting, the air pressure switch will close. A 120 volt circuit will be completed through the venting manual reset switch and on to the 120 volt gas valve. The 120 volt gas valve will open allowing gas to flow to the burner. The hot surface ignitor will establish a main burner flame.

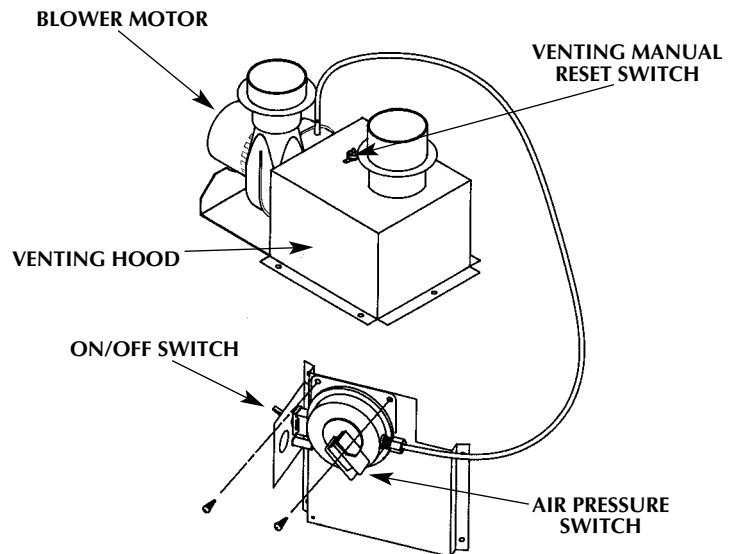

## ALL MODELS

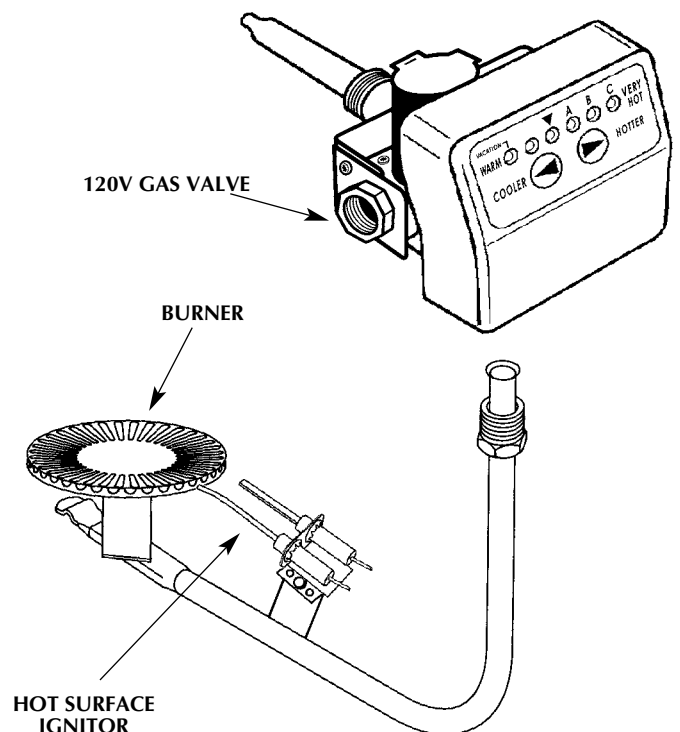

# Operating (cont'd)

## ▲WARNING

**BEFORE OPERATING [PROPANE (L.P.) GAS WATER HEATERS]:** Propane (L.P.) gas is heavier than air. Should there be a leak in the system, the gas will settle near the ground. Basements, crawl spaces, skirted areas under manufactured (mobile) homes (even when ventilated), closets and areas below ground level will serve as pockets for the accumulation of this gas. Before attempting to operate the water heater or turning a nearby electrical light switch, be absolutely sure there is no accumulated gas in the area. Search for odor of gas by sniffing at ground level in the vicinity of the appliance. If odor is detected, follow the steps indicated at "For Your Safety" on the cover page of this manual, then leave the premises.

Operating instructions are located on front of the water heater, above or to one side of the gas control valve. See page 23.

## ▲WARNING

**AN ODORANT IS ADDED TO THE GAS USED BY THIS WATER HEATER.**

**FOR YOUR SAFETY IF YOU SMELL GAS:**

1. Do not try to light any appliance.
2. Do not touch any electrical switch; do not use any phone in your building.
3. Immediately call you gas supplier from a neighbor's phone. Follow the gas supplier's instructions.
4. If you cannot reach your gas supplier, call the fire department.

## CHECK FOR LEAKS

Be sure to check all your gas pipes for leaks before operating your water heater. Use a soapy water solution, not a match or open flame. Check the factory gas fittings when the main burner is turned "ON".

## WATER HEATING IGNITION SEQUENCE

(Make sure gas and electric power are connected properly)

1. The ignition control module is powered and monitors the system, waiting for a call for heat from the thermostat.
2. The thermostat calls for heat by reading a resistance value within a given range directly proportional to water temperature.

3. The control module:
  - a) Checks the pressure switch for an open circuit.
  - b) Energizes the blower.
  - c) Checks the pressure switch for a closed circuit to prove draft.
  - d) Sends line voltage to the hot surface igniter with a 20-second warm up period.
  - e) Opens the gas valve and checks the sensing rod for flame.
4. The burner heats the water to the desired thermostat setting.
  - a) The resistance in the thermostat rises to the value selected by the temperature control knob.
  - b) The control module closes the gas valve and 5 seconds later, removes power from the blower.
5. Cycle is completed.

## CONTROL SEQUENCE - HOT SURFACE DIRECT IGNITION

Pre-purge	5 sec.
HSI Warm-up	20 sec.
Ignition Activation Period	4 sec.
Flame Recognition Period	1 sec.
Ignition Trial	4 sec.
Interpurge	5 sec.
Post-purge	5 sec.
Retries	2
Reset from Lockout	1 hr.
Flame Sensing (Nominal)	
HSI Off/Run Mode	4.0 $\mu$ DC

# Operating (cont'd)

## FOR YOUR SAFETY READ BEFORE OPERATING



**WARNING:** If you do not follow these instructions exactly, a fire or explosion may result causing property damage, personal injury or loss of life.



**BEFORE OPERATING: ENTIRE SYSTEM MUST BE FILLED WITH WATER AND AIR PURGED FROM ALL LINES.**

- A. This appliance does not have a pilot. It is equipped with an ignition device which automatically lights the burner. **Do NOT try to light the burner by hand.**
- B. **BEFORE OPERATING** smell all around the appliance area for gas. Be sure to smell next to the floor because some gas is heavier than air and will settle on the floor.  
**WHAT TO DO IF YOU SMELL GAS:**
  - Do not try to light any appliance.
  - Do not touch any electric switch; do not use any phone in your building.
  - Immediately call your gas supplier from a neighbor's phone. Follow the gas supplier's instructions.
- If you cannot reach your gas supplier, call the fire department.
- C. Use only your hand to push in the gas control buttons. Never use tools. If the control buttons will not push in, don't try to repair them, call a qualified service technician. Force or attempted repair may result in a fire or explosion.
- D. Do not use this appliance if any part has been under water. Immediately contact a qualified installer or service agency to replace a flooded water heater. Do not attempt to repair the unit! It must be replaced!

## OPERATING INSTRUCTIONS

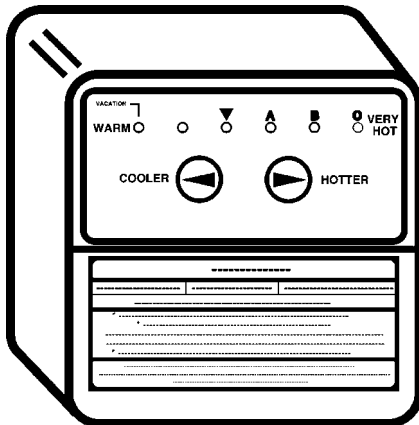

1. STOP! Read the safety information above on this label.
2. Set the ON/OFF switch on the control box to the "ON" position.
3. Set the thermostat to the lowest setting by first pressing the COOLER and HOTTER buttons together and holding for 1 second. Then press the COOLER button until the WARM indicator light appears.
4. Set the ON/OFF switch on the control box to the "OFF" position.
5. This appliance is equipped with a device which automatically lights the burner.  
**DO NOT TRY TO LIGHT THE BURNER BY HAND.**
6. Wait five (5) minutes to clear out any gas. If you then smell gas, STOP! Follow "B" in the safety information above on this label. If you don't smell gas, go to the next step.
7. Turn on all electrical power to the appliance.
8. Set the ON/OFF switch on the control box to the "ON" position.
9. Set the thermostat to desired setting by first pressing the COOLER and HOTTER buttons together and holding for 1 second. Then press the HOTTER button .
10. WATER TEMPERATURE ADJUSTMENT is approximately 120°F.  
 **CAUTION: Hotter water increases the risk of scald injury. Consult the instruction manual before changing temperature.**
11. If the appliance will not operate, follow the instructions "TO TURN OFF GAS TO APPLIANCE" and call your technician or gas supplier.  
 **WARNING: TURN OFF ALL ELECTRIC POWER BEFORE SERVICING**

## TO TURN OFF GAS TO APPLIANCE

1. Set thermostat to the lowest setting by first pressing the COOLER and HOTTER buttons together and holding for 1 second. Then press the COOLER button until the WARM indicator light appears.
2. Set the ON/OFF switch on the control box to the "OFF" position.
3. Turn off all electric power to the appliance if service is to be performed.

# Temperature Regulation

Due to the nature of the typical gas water heater, the water temperature in certain situations may vary up to 30°F higher or lower at the point of use such as, bathtubs, showers, sink, etc.

Any water heaters intended purpose is to heat water. Hot water is needed for cleaning, (bodies, dishes, clothing). Hot water will present a scald hazard. Depending on the time element, and the people involved (normal adults, children, toddlers, elderly, infirm, etc.) scalding may occur at different temperatures.

**▲WARNING**

**HOTTER WATER CAN SCALD:** Water heaters are intended to produce hot water. Water heated to a temperature which will satisfy clothes washing, dish washing, and other sanitizing needs can scald and permanently injure you upon contact. Some people are more likely to be permanently injured by hot water than others. These include the elderly, children, the infirm, or physically/mentally handicapped. If anyone using hot water in your home fits into one of these groups or if there is a local code or state law requiring a certain temperature water at the hot water tap, then you must take special precautions. In addition to using the lowest possible temperature setting that satisfies your hot water needs, some type of tempering device, such as a mixing valve, should be used at the hot water taps used by these people or at the water heater. Mixing valves are available at plumbing supply or hardware stores. A qualified plumber should be consulted. Follow manufacturers instructions for installation of the valves. Before changing the factory setting on the thermostat, read the "Temperature Regulation" section in this manual.

**▲WARNING**

Never allow small children to use a hot water tap, or to draw their own bath water. Never leave a child or handicapped person unattended in a bathtub or shower.

The thermostat of this water heater has been factory set at its lowest position, to reduce the risk of scald injury. It is adjustable and must be reset to the desired temperature setting. The mark ( ▼ ) (on temperature setting of gas valve) indicative of approximately 120°F is preferred starting point. Some states have a requirement for a lower setting. If you need hotter water, follow directions for temperature adjustment, but beware of the warnings in this section.

Pressing the "COOLER" button decreases temperature and pressing the "HOTTER" button increases the temperature.

To avoid any unintentional changes in water temperature settings, the control has a tamper resistant feature for

changing the temperature setting. To change the temperature setting follow these instructions:

1. "Wake Up" the temperature indicators by holding down both "COOLER" and "HOTTER" temperature adjustment buttons at the same time for one second (See Figure below). One or two of the temperature indicators will light up. These indicators will only remain on for 30 seconds if no further buttons are pressed. After 30 seconds the control will go back to "Sleep" mode.
2. Release both of the temperature adjustment buttons.
  - A. To decrease the temperature press and release the "COOLER" button until the desired setting is reached.
  - b. To increase the temperature press and release the "HOTTER" button until the desired setting is reached.

NOTE: Holding down the button will not continue to lower or raise the temperature setting. The button must be pressed and released for each temperature change desired.

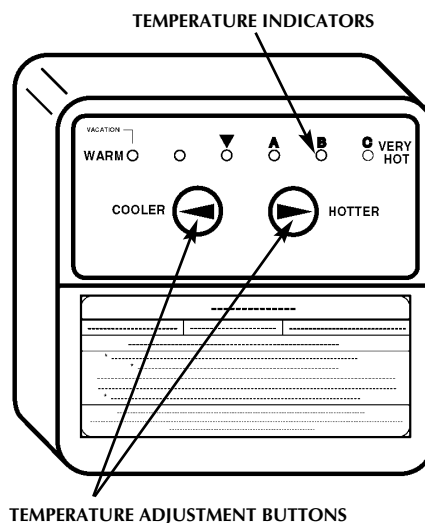

Temperature Setting	Display ▼ A B C	Time to Produce 2nd & 3rd Degree Burns on Adult Skin
C - Flashing = approx. 160°F	○ ○ ○ ○ ●	About 1/2 seconds
C = approx. 150°F	○ ○ ○ ○ ●	About 1-1/2 seconds
B = approx. 140°F	○ ○ ○ ● ○	Less than 5 seconds
A = approx. 130°F	○ ○ ○ ● ○ ○	About 30 seconds
▼ = approx. 120°F	○ ○ ● ○ ○ ○	More than 5 minutes
WARM = approx. 80°F	● ○ ○ ○ ○ ○	-----

**NOTE: Water temperature range of 120°–140°F recommended by most dishwasher manufacturers.**

**▲WARNING**

Should overheating occur or the gas supply fail to shut off, turn "OFF" the manual gas control valve to the appliance.



# For Your Information

## Start Up Conditions

### CONDENSATION

Whenever the water heater is filled with cold water, a certain amount of condensation will form while the burner is on. A water heater may appear to be leaking when in fact the water is condensing. This usually happens when:

- When a new water heater is filled with cold water for the first time.
- When gas burns and water vapor is produced in water heaters, particularly high efficiency models where flue temperatures are lower.
- When you use large amounts of hot water in a short time and the refill water is very cold.

Moisture from the products of combustion condenses on the cooler tank surfaces and form drops of water which may fall onto the burner or other hot surfaces and produce a "sizzling" or "frying" noise.

Because of the suddenness and amount of water, condensation water may be diagnosed as a "tank leak". After the water in the tank warms up (about 1-2 hours), the condition should disappear.

Do not assume the water heater is leaking until there has been enough time for the water in the tank to warm up.

An undersized water heater will cause more condensation. The water heater must be sized properly to meet the family's demands for hot water including dishwashers, washing machines and shower heads.

Excessive condensation may be noticed during the winter and early spring months when incoming water temperatures are at their lowest.

Good venting is essential for a gas fired water heater to operate properly as well as to carry away products of combustion and water vapor.

### SMOKE/ODOR

It is not uncommon to experience a small amount of smoke and odor during the initial start-up. This is due to burning off of oil from metal parts, and will disappear in a short while.

### THERMAL EXPANSION

Because of such events as high line pressure, frequent cut-offs, the effects of water hammer among others, water supply systems may have installed devices such as pressure reducing valves, check valves, back flow preventers, etc...to control these types of problems. When these devices are not equipped with an internal by-pass, and no other measures are taken, the devices cause the water system to be closed. As water is heated, it expands (thermal expansion) and closed systems do not allow for the expansion of heated water.

The water within the water heater tank expands as it is heated and increases the pressure of the water system. If the relieving point of the water heater's temperature-pressure relief valve is reached, the valve will relieve the excess pressure. **The temperature-pressure relief valve is not intended for the constant relief of thermal expansion.** This is an unacceptable condition and must be corrected.

It is recommended that any devices installed which could create a closed system have a by-pass and/or the system have an expansion tank to relieve the pressure built by thermal expansion in the water system. Expansion tanks are available for ordering through local plumbing supply houses. Contact the local water supplier and/or plumbing contractor for assistance in controlling these situations.

### STRANGE SOUNDS

Possible noises due to expansion and contraction of some metal parts during periods of heat-up and cool-down do not represent harmful or dangerous conditions.

Condensation causes sizzling and popping with the burner area during heating and cooling periods and should be considered normal. See "Condensation" in this section.

## Operational Conditions

### SMELLY WATER

In each water heater there is installed at least one anode rod (see parts section) for corrosion protection of the tank. Certain water conditions will cause a reaction between this rod and the water. The most common complaint associated with the anode rod is one of a "rotten egg smell". This odor is derived from hydrogen sulfide gas dissolved in the water. The smell is the result of four factors which must all be present for the odor to develop:

- a concentration of sulfate in the supply water.
- little or no dissolved oxygen in the water.
- a sulfate reducing bacteria within the water heater. (This harmless bacteria is non-toxic to humans.)
- an excess of active hydrogen in the tank. This is caused by the corrosion protective action of the anode.

Smelly water may be eliminated or reduced in some water heater models by replacing the anode(s) with one of less active material, and then chlorinating the water heater tank and all hot water lines. Contact the local water heater supplier for further information concerning an Anode Replacement Kit #9000029 and this Chlorination Treatment.

If the smelly water persists after the anode replacement and chlorination treatment, we can only suggest that continuous chlorination and filtering conditioning equipment be considered to eliminate the water problem.

**Do not remove the anode leaving the tank unprotected. By doing so, all warranty on the water heater tank is voided.**

# For Your Information (cont'd)

## Operational Conditions (cont'd)

### "AIR" IN HOT WATER FAUCETS

#### ▲WARNING

**HYDROGEN GAS:** Hydrogen gas can be produced in a hot water system that has not been used for a long period of time (generally two weeks or more). Hydrogen gas is extremely flammable and explosive. To prevent the possibility of injury under these conditions, we recommend the hot water faucet be opened for several minutes at the kitchen sink before any electrical appliances which are connected to the hot water system are used (such as a dishwasher or washing machine). If hydrogen gas is present, there will probably be an unusual sound similar to air escaping through the pipe as the hot water faucet is opened. There must be no smoking or open flame near the faucet at the time it is open.

### VENTING MANUAL RESET SWITCH

There is a venting manual reset switch located on the venting hood. If the switch is activated, it will not reset itself. Before resetting this reset switch, check for flue blockage and propriety of the venting system. To reset, press the red button.

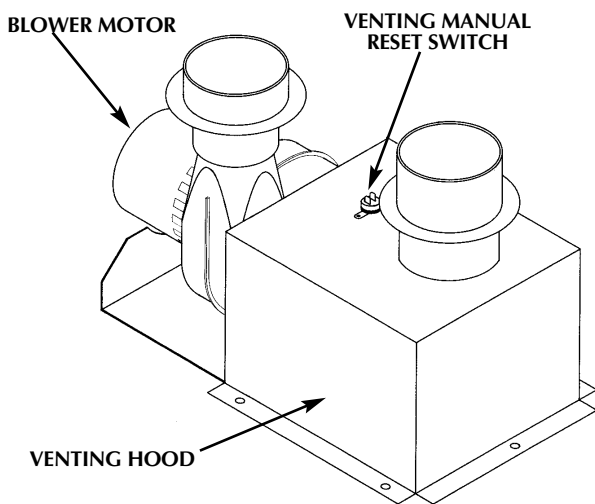

### HIGH TEMPERATURE LIMIT SWITCH (Single-Use Type Energy Cut Off)

The thermostat has a built-in limit switch which will actuate in case of excessive water temperatures. The heater cannot be relit until the gas control valve is replaced. It is important that a serviceman be called to determine the reason for limit operation and thus avoid repeated thermostat replacement. Lower the temperature adjustment setting on new control.

#### ▲WARNING

Should overheating occur or the gas supply fail to shut off, turn "off" the manual gas control valve to the appliance.

### NOT ENOUGH OR NO HOT WATER

1. Check the manual gas shut off valve to be sure it is open.
2. The ON/OFF switch on the control box must be "ON".
3. The temperature button adjustment may be set too low. See the "Temperature Regulation" section.
4. The gas company can check the gas input to see if it is correct. An underfired water heater will not heat water as quickly.
5. Look for leaking or open hot water faucet's. Make sure all are closed.
6. The cold water inlet temperature may be colder during the winter months. It will take longer to heat the water and seem like less hot water.
7. If you cannot find what is wrong, call the local gas utility and/or plumbing contractor.

### WATER IS TOO HOT

1. The temperature adjustment setting may be set too high. See the "Temperature Regulation" section.

**NOTE: A period of time is necessary after an adjustment has been made for the water temperature to reach the new temperature setting.**

2. If lower temperature settings will not lower the water temperature, call the local gas utility.

# Periodic Maintenance

## Venting System Inspection

At least once a year a visual inspection should be made of the venting system. You should look for:

1. Obstructions which could cause improper venting. The combustion and ventilation air flow must not be obstructed.
2. Damage or deterioration which could cause improper venting or leakage of combustion products.
3. Rusted flakes around top of water heater.

### ▲WARNING

Be sure the vent piping is properly connected to prevent escape of dangerous flue gasses which could cause deadly asphyxiation.

### ▲WARNING

Obstructions and deteriorated vent systems may present serious health risk or asphyxiation.

### ▲WARNING

Chemical vapor corrosion of the flue and vent system may occur if air for combustion contains certain chemical vapors. Spray can propellants, cleaning solvents, refrigerator and air conditioner refrigerants, swimming pool chemicals, calcium and sodium chloride, waxes, bleach and process chemicals are typical compounds which are potentially corrosive.

### ▲WARNING

If after inspection of the vent system you found sooting or deterioration, something is wrong. Call the local gas utility to correct the problem and clean or replace the flue and venting before resuming operation of the water heater.

## Burner Inspection

### ▲WARNING

Flood damage to a water heater may not be readily visible or immediately detectable. However, over a period of time a flooded water heater will create dangerous conditions which can cause DEATH, SERIOUS BODILY INJURY, OR PROPERTY DAMAGE. Contact a qualified service technician or contractor to replace a flooded water heater. Do not attempt to repair the unit! It must be replaced!

Check main burner every 12 months for proper flame characteristics. This is done by removing outer and inner doors on heater. The main burner should provide complete combustion of gas; ignite rapidly; give reasonably quiet operation; cause no excessive flame lifting from burner ports. Make sure that the flow of combustion and ventilation air is not blocked.

If proper flame characteristics are not evident, check for accumulation of lint or other foreign material that restricts or blocks the air openings in the heater or burner. Also check Combustion Air and Ventilation requirements.

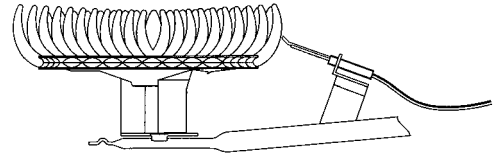

### ▲WARNING

Soot build-up indicates a problem that requires correction before further use. Turn "OFF" gas to water heater and leave "OFF" until repairs are made, because failure to correct the cause of the sooting can result in a fire.

## Burner Cleaning

**NOTE:** Burner assembly must be handled carefully to avoid damaging the hot surface ignitor.

In the event your burner needs cleaning, use the following instructions:

If inspection of the burner shows that cleaning is required, turn the ON/OFF rocker switch located on the control box to "OFF" position and allow the burner to cool.

Loose deposits on or around the burner can be removed by carefully using the hose of a vacuum cleaner inserted through the access door of the water heater. If the burner needs to be removed for additional cleaning, call the local gas utility or qualified service agent to remove and clean the burner with a soft brush. Clean main burner orifice with a suitable soft material. Correct the problem that required the burner to be cleaned.

# Periodic Maintenance (cont'd)

## L.P. Gas Control Valve & Burner Assembly Replacement Information

### ▲WARNING

#### PROPANE (L.P.) GAS CONTROL VALVE AND BURNER ASSEMBLY REPLACEMENT INFORMATION.

For Propane (L.P.) Gas Models Only:

Your water heater is equipped with a Propane (L.P.) gas control valve and a main burner assembly with left hand threads for the following fittings and their connections.

- (1) The connection between the manifold and the gas control valve (A to B) are left hand threads.
- (2) The connection between the main burner orifice and the manifold (C to D) are left hand threads.

For ordering these replacement parts, please refer to the "Repair Parts" section of this manual.

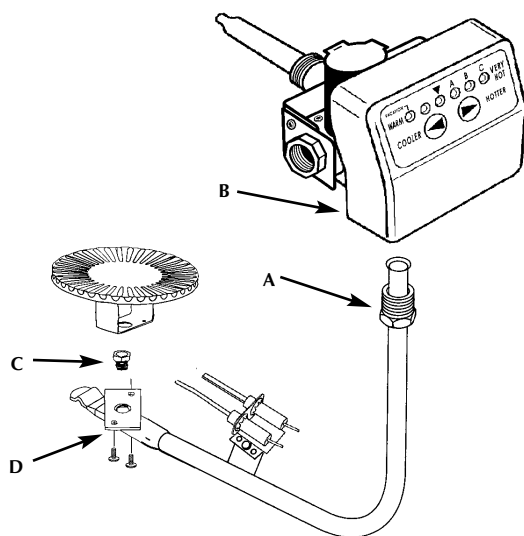

## Anode Rod Inspection

The anode rod is used to protect the tank from corrosion. Most hot water tanks are equipped with an anode rod. The submerged rod sacrifices itself to protect the tank. Instead of corroding the tank, water ions attack and eat away the anode rod. This does not affect the water's taste or color. The rod must be maintained to keep the tank in operating condition.

Anode deterioration depends on water conductivity, not necessarily water condition. A corroded or pitted anode rod indicates high water conductivity and should be checked and/or replaced more often than an anode rod that appears to be intact. Replacement of a depleted anode rod can extend the life of your water heater. Inspection should be conducted by a qualified technician, and at a minimum should be checked annually after the warranty period.

## Temperature-Pressure Relief Valve Operation

The temperature-pressure relief valve must be manually operated at least once a year.

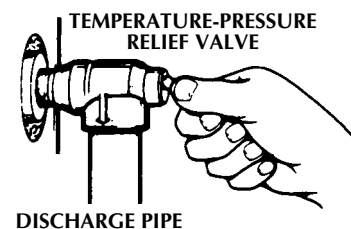

### ▲WARNING

When checking the temperature-pressure relief valve operation, make sure that (1) no one is in front of or around the outlet of the temperature-pressure relief valve discharge line, and (2) that the water manually discharged will not cause any property damage because the water may be extremely hot.

If after manually operating the valve, it fails to completely reset and continues to release water, immediately close the cold water inlet to the water heater, follow the draining instructions, and replace the temperature-pressure relief valve with a new one.

Failure to install and maintain a new properly listed temperature-pressure relief valve will release the manufacturer from any claim which might result from excessive temperature or pressure.

### ▲WARNING

If the temperature-pressure relief valve on the appliance weeps or discharges periodically, this may be due to thermal expansion. Your water heater may have a check valve installed in the water line or a water meter with a check valve. Consult the water supplier and/or plumbing contractor for further information. Do not plug the temperature-pressure relief valve.

## Housekeeping

Vacuum around base of water heater for dust, dirt, and lint on a regular basis.

### ▲WARNING

**INSTALLED IN SUITABLE AREA:** To insure sufficient ventilation and combustion air supply, proper clearances from the water heater must be maintained. See "Locating the New Water Heater" section. Combustible materials such as clothing, cleaning materials, or flammable liquids, etc. must not be placed against or adjacent to the water heater which can cause a fire.

# Periodic Maintenance (cont'd)

## Draining

The water heater should be drained if being shut down during freezing temperatures. Also periodic draining and cleaning of sediment from the tank may be necessary.

1. Turn "OFF" gas supply to water heater.
2. CLOSE the cold water inlet valve to the water heater.
3. OPEN a nearby hot water faucet and leave open to allow for draining.
4. Connect a hose to the drain valve and terminate to an adequate drain.
5. OPEN the water heater drain valve to allow for tank draining.

**NOTE: If the water heater is going to be shut down and drained for an extended period, the drain valve should be left open with hose connected allowing water to terminate to an adequate drain.**

6. Close the drain valve.
7. Follow instructions in the "Filling The Water Heater" section.
8. Follow the lighting instructions in the "Lighting" section to restart the water heater.

## Drain Valve Washer Replacement

**NOTE: For replacement, use a 17/32" x 13/64" x 1/8" thick washer available at your nearest hardware store. For ordering replacement washers, refer to the "Repair Parts" section.**

1. Turn "OFF" gas supply to water heater.
2. Follow "Draining" instructions.
3. Turning counter clockwise, remove the hex cap below the screw handle.
4. Remove the washer and put the new one in place.
5. Screw the handle and cap assembly back into the drain valve and retighten using a wrench. **DO NOT OVER TIGHTEN.**
6. Follow instructions in the "Filling The Water Heater" section.
7. Check for leaks.
8. Follow the lighting instructions in the "Lighting" section to restart the water heater.

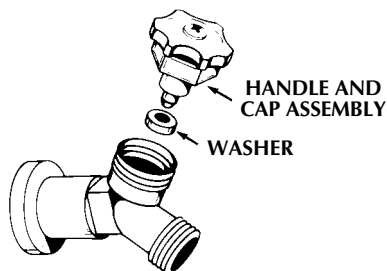

## Service

If a condition persists or you are uncertain about the operation of the water heater, let a qualified person check it out. Call the local utility and/or plumbing contractor.

# Leakage Checkpoints

Use this guide to check a “Leaking” water heater. Many suspected “Leakers” are not leaking tanks. Often the source of the water can be found and corrected.

If you are not thoroughly familiar with gas codes your water heater, and safety practices, contact the gas utility to check the water heater.

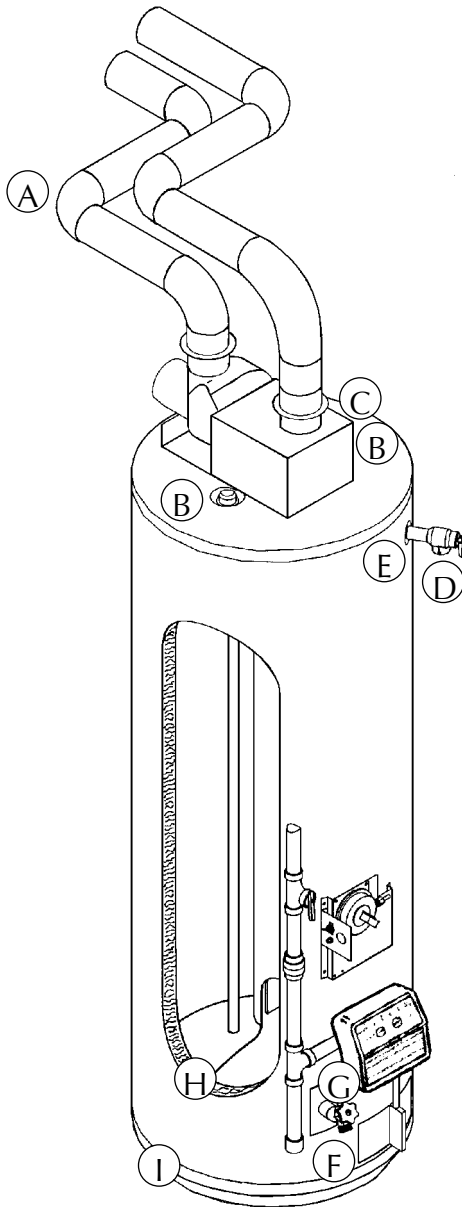

## ▲CAUTION

Read this manual first. Then before checking the water heater make sure the gas supply has been turned “OFF”, and never turn the gas “ON” before the tank is completely full of water.

## ▲CAUTION

Never use this water heater unless it is completely filled with water. To prevent damage to the tank, the tank must be filled with water. Water must flow from the hot water faucet before turning “ON” gas to the water heater.

- Ⓐ Water at the vent pipe is water vapor which has condensed out of the combustion products. This is caused by a problem in the vent. Contact the gas utility.
- Ⓑ \* Condensation may be seen on pipes in humid weather or pipe connections may be leaking.
- Ⓒ \* The primary anode rod fitting may be leaking.
- Ⓓ Small amounts of water from temperature-pressure relief valve may be due to thermal expansion or high water pressure in your area.
- Ⓔ \* The temperature-pressure relief valve may be leaking at the tank fitting.
- Ⓕ Water from a drain valve may be due to the valve opened slightly.
- Ⓖ \* The drain valve may be leaking at the tank fitting.
- Ⓗ Combustion products contain water vapor which can condense on the cooler surfaces of the tank. Droplets form and drip into the fire or run on the floor. This is common at the time of startup after installation and when incoming water is cold.
- Ⓘ Water in the water heater bottom or on the floor may be from condensation, loose connections, or the relief valve. DO NOT replace the water heater until a full inspection of all possible water sources is made and necessary corrective steps taken.

Leakage from other appliances, water lines, or ground seepage should also be checked.

\* To check where threaded portion enters tank, insert cotton swab between jacket opening and fitting. If cotton is wet, follow “Draining” instructions in the “Periodic Maintenance” section and then remove fitting. Put pipe dope or teflon tape on the threads and replace. Then follow “Filling the Water Heater” instructions in the “Installing the New Water Heater” section.

# Troubleshooting

## ▲WARNING

This troubleshooting guide has been supplied for use by qualified service personnel who have a complete understanding of both electricity and gas.

## ▲WARNING

Label all wiring before disconnecting any wiring; to ensure correct reconnection. Failure to follow this instruction could cause improper and possible dangerous operation, resulting in DEATH, SERIOUS BODILY INJURY, OR PROPERTY DAMAGE.

### THERMOSTAT AND GAS SUPPLY CHECK

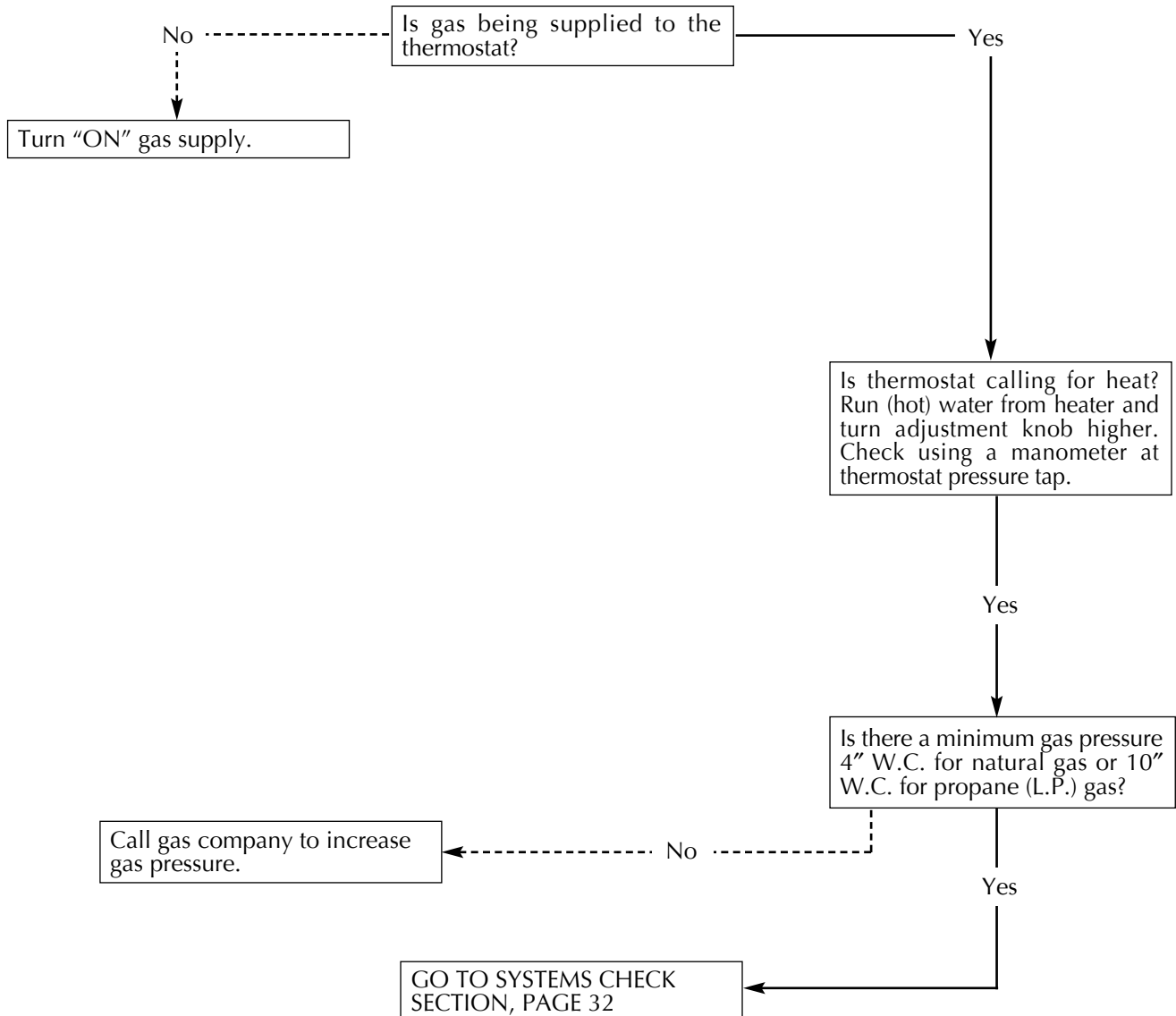











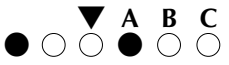

# Troubleshooting (cont'd)

## SYSTEMS CHECK

Please check guidelines below. For your safety, water heater service should be performed only by a qualified service technician.

### ▲WARNING

**DO NOT BY-PASS ANY CONTROLS TO MAKE HEATER OPERATE. OPERATE ONLY AS WIRED FROM FACTORY.**

LED STATUS	PROBLEM	SOLUTION
	An open earth ground circuit to the ignition system.	<ol style="list-style-type: none"> <li>1. Check that the earth ground connection is properly connected.</li> <li>2. Check that the ground conductor on the water heater is properly connected.</li> </ol>
	Wiring error or a high resistance to earth ground.	<ol style="list-style-type: none"> <li>1. Check for proper connection of line neutral and hot wires.</li> <li>2. Check that the water heater is securely connected to earth ground.</li> </ol>
	Pressure switch remained closed longer than 5 seconds after the call for heat began.	<ol style="list-style-type: none"> <li>1. Pressure switch wiring is incorrect.</li> <li>2. Replace pressure switch.</li> </ol>
	Pressure switch remained opened longer than 5 seconds after the combustion blower was energized.	<ol style="list-style-type: none"> <li>1. Pressure switch wiring is incorrect.</li> <li>2. Pressure switch tubing not connected correctly.</li> <li>3. Air intake or exhaust obstructed.</li> </ol>
	Error in the hot surface ignitor circuit.	<ol style="list-style-type: none"> <li>1. Check that all wiring is correct and secure.</li> <li>2. Replace hot surface ignitor.</li> </ol>
	System in lockout.	<ol style="list-style-type: none"> <li>1. Gas supply is off or too low to operate.</li> <li>2. Hot surface ignitor not positioned correctly.</li> <li>3. Low voltage to the water heater.</li> <li>4. Electric polarity to unit is incorrect - test and correct.</li> </ol>
	Problem in the gas valve driver circuit.	<ol style="list-style-type: none"> <li>1. Turn power to the water heater off for 10 seconds and then back on.</li> <li>2. Replace gas control valve.</li> </ol>
	Problem with the internal circuit.	<ol style="list-style-type: none"> <li>1. Turn power to the water heater off for 10 seconds and then back on.</li> <li>2. Replace gas control valve.</li> </ol>
	Problem with the internal circuit.	<ol style="list-style-type: none"> <li>1. Turn power to the water heater off for 10 seconds and then back on.</li> <li>2. Replace gas control valve.</li> </ol>
	Flame signal sensed out of proper sequence.	<ol style="list-style-type: none"> <li>1. Replace gas control valve.</li> </ol>
	ECO activated.	<ol style="list-style-type: none"> <li>1. Replace gas control valve.</li> </ol>
	One of the temperature adjust buttons stuck closed.	<ol style="list-style-type: none"> <li>1. Press and release each of the buttons once.</li> <li>2. Replace gas control valve.</li> </ol>
	Water temperature sensor is either open or short circuited.	<ol style="list-style-type: none"> <li>1. Check that all wiring is correct and secure.</li> <li>2. Replace gas control valve.</li> </ol>



# Troubleshooting (cont'd)

PROBLEM	CAUSE	SOLUTION
NOT ENOUGH HOT WATER	<b>Blower will not run.</b>	
	A) "ON/OFF" control switch turned off.	Turn switch to the "ON" position.
	B) Blower unplugged.	Plug blower back into 115 VAC. outlet.
	C) No power at outlet.	Repair service to outlet.
	D) Thermostat defective.	Replace thermostat.
	E) Control harness defective.	Replace control harness.
	F) High limit control circuit open.	Replace ECO.
	G) Blower motor defective.	Replace Blower Assembly.
	<b>Thermostat problems.</b>	
	A) Thermostat set too low.	Set temperature control higher.
	B) Thermostat or ECO defective.	Replace thermostat or ECO as required.
	<b>Others</b>	
	A) Heater undersized.	Reduce hot water use.
B) Low gas pressure.	Contact dealer.	
C) Incoming water is unusually cold.	Allow more time for heater to reheat.	
D) Leaking hot water pipes or fixtures.	Have plumber check and repair leaks.	
VENT PIPE TOO HOT (ABOVE 170°F)	A) Defective air flow restrictor.	Take unit out of service immediately, call a service representative.
	B) Not enough dilution air to mix with flue gases in inlet elbow.	Proper dilution air must be provided for combustion and dilution of flue temp. Refer to "INSTALLING THE NEW WATER HEATER" section.
	C) Dilution air too hot for mixing with flue gases.	Supply air is too hot. Check for heat sources around intake terminal and blockage of dilution air leg.
	D) Wrong burner orifice.	Install correct orifice.
YELLOW FLAME	A) Dirt in burner ports	Turn off heater and gas, clean burner head.
	B) Combustion air path restricted.	Check intake venting arrangements for obstructions.
	C) Not enough dilution air for proper combustion.	Check Intake venting arrangement for obstructions.
CONDENSATION	A) Water on the floor under heater.	See "CONDENSATION" section.
	B) Water dripping from blower assembly.	Provide drip "TEE" to catch condensation from horizontal section of exhaust vent close to blower assembly.
WATER LEAKS	Improperly sealed, hot or cold supply connections, relief valve, drain valve or thermostat threads.	Tighten threaded connections.
	Leakage from other appliances or water lines.	Inspect other appliances near water heater.
	Condensation of flue products.	See "CONDENSATION" section.
LEAKING T&P	Thermal expansion in closed water system.	Install thermal expansion tank (DO NOT plug T&P valve).
	Improperly seated valve.	Check relief valve for proper operation (DO NOT plug T&P valve).
HOT WATER ODORS (Refer to CATHODIC PROTECTION)	High sulfate or mineral content in water supply.	Drain and flush heater thoroughly then refill.
	Bacteria in water supply.	Chlorinate water supply.
WATER TOO HOT	Thermostat set too high.	Refer to TEMPERATURE REGULATION.
WATER HEATER SOUNDS SIZZLING-RUMBLING	Condensation dripping on burner.	See "CONDENSATION" section.
	Sediment at bottom of heater tank.	Clean sediment from tank. Refer to DRAINING instruction in Maintenance section of manual.
SOOTING	Improper combustion.	Refer to COMBUSTION AIR AND VENTILATION on pages 8 and 9.
HEATER LIGHTS BUT GOES OUT IN 4-5 SECONDS	Outlet polarity is reversed.	Test polarity and correct.

# Repair Parts

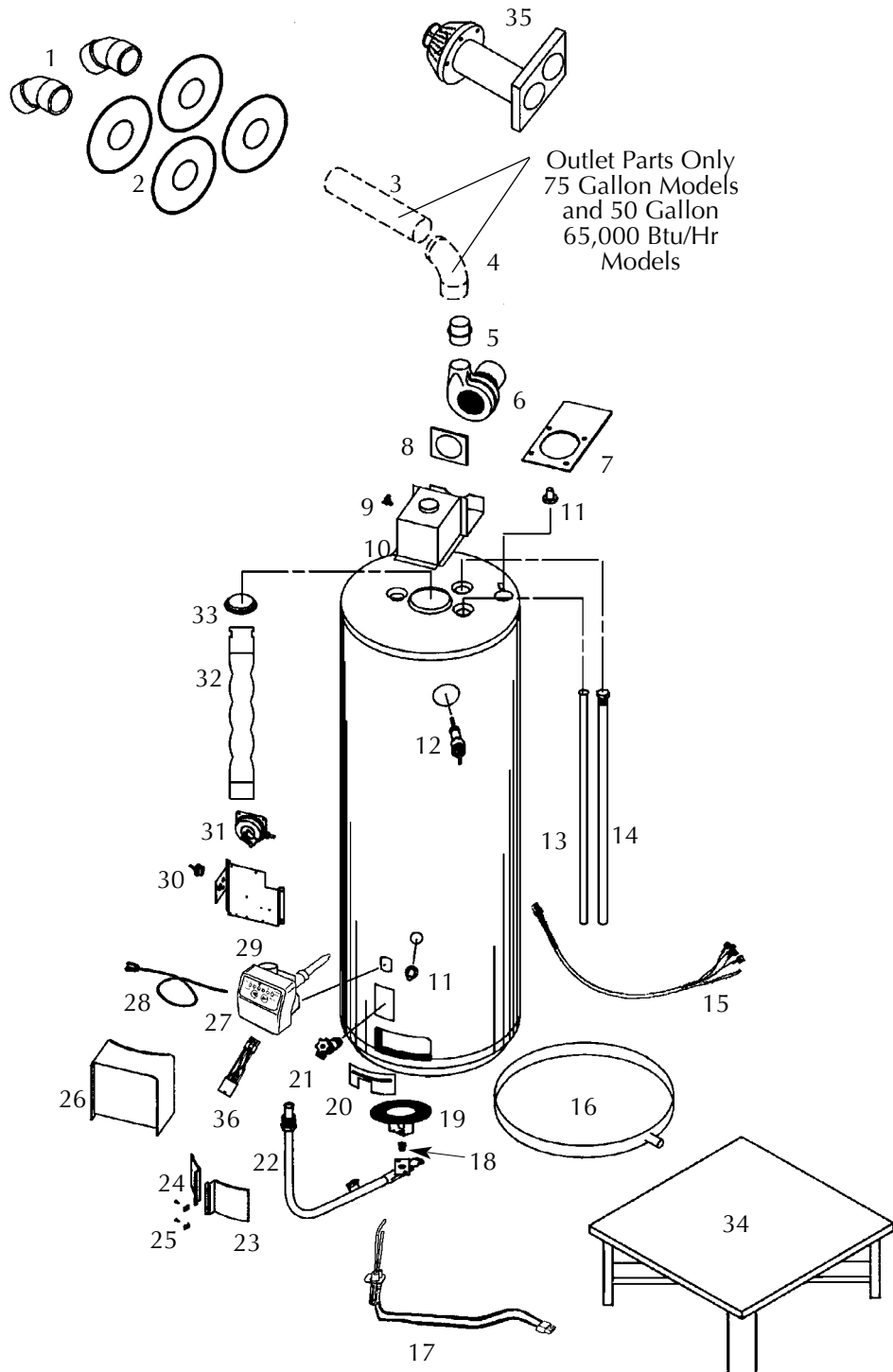

# Repair Parts (cont'd)

KEY NO.	PART DESCRIPTION
1.	Vent Cap w/Screen
2.	Adaptor, Flue Mounting
3.	5' ABS Schedule 40 Vent Pipe
4.	90° ABS Schedule 40 Elbow
5.	Vent/Blower Adapter
6.	Blower
7.	Flue Adaptor Gasket (6" x 10.102")
8.	Blower Gasket
9.	Venting; Manual Reset Switch
10.	Vent Hood Assembly
11.	Rubber Gasket – Wiring
12.	T&P Valve
13.	Dip Tube
14.	Anode Rod
15.	Wiring Harness
16.	Drain Pan
17.	Hot Surface Ignition Assembly
18.	Orifice (Natural) Standard
18.	Orifice (L.P.) Standard
18.	Orifice (Nat.) High Altitude
18.	Orifice (L.P.) High Altitude

KEY NO.	PART DESCRIPTION
19.	Burner Assembly (Nat.)
19.	Burner Assembly (L.P.)
20.	Inner Door
21.	Drain Valve
22.	Manifold (Natural)
22.	Manifold (L.P.)
23.	Right Access Door w/Gasket
24.	Left Access Door w/Gasket
25A.	Access Door Clips (2)
25B.	Jacket/Access Door Clips (8)
26.	Pressure Switch (Air) Cover
27.	Gas Thermostat (Nat.)
27.	Gas Thermostat (L.P.)
28.	Power Cord
29.	Mounting Bracket
30.	On/Off Switch
31.	Pressure Switch (Air)
32.	Flue Baffle Assembly
33.	Baffle Adaptor Collar Assembly
34.	Water Heater Stand
35.	Optional (Deluxe) Horizontal Vent Kit
36.	4 to 5 pin adapter

Now that you have purchased this Water Heater, should a need ever exist for repair parts or service, simply contact the company it was purchased from or the manufacturer listed on the model rating plate on the water heater.

Be sure to provide all pertinent facts when you call or visit.

Selling prices will be furnished on request or parts will be shipped at prevailing price and you will be billed accordingly.

The model number of your Gas Water Heater will be found on the model rating plate located above the gas control valve.

WHEN ORDERING REPAIR PARTS, ALWAYS GIVE THE FOLLOWING INFORMATION:

MODEL NUMBER	(TYPE GAS) NATURAL OR PROPANE (L.P.)
SERIAL NUMBER	PART DESCRIPTION
	PART NUMBER

**THIS IS A REPAIR PARTS LIST, NOT A PACKING LIST.**

