

— SOLAR COLLECTOR SEAMED METAL ROOF MOUNTING INSTRUCTIONS —

CAUTION

ALL PERSONS WORKING ON ROOFS SHOULD HAVE SUCCESSFULLY COMPLETED A FALL SAFETY COURSE AND SHOULD BE PROPERLY EQUIPPED WITH THE APPROPRIATE SAFETY EQUIPMENT

⚠ WARNING

AFTER COMPLETION OF THE COLLECTOR MOUNTING AND PRIOR TO SYSTEM CHARGING THE COLLECTORS MUST BE COVERED BY A BLANKET OR OTHER MEANS TO AVOID SOLAR RADIATION FROM HEATING THE COLLECTORS. THE SURFACES OF THE COLLECTOR CAN BECOME EXTREMELY HOT AND COULD POSE A BURN HAZARD.

structural members of the roof with the stainless steel hardware provided. The solar collector must be attached to the mounting hardware. See Figure 7.

Preserving the integrity of the roof membrane is the most important roofing consideration. Ensure that all roof penetrations required to plumb and mount the solar collector are properly flashed and sealed in accordance with standard roofing practices.

If the region is subject to hurricane conditions, additional steps may be required to secure the collector and mounting hardware to the structural members. In certain areas of the country, local building codes may require collector wind load testing or prescribe specific mounting procedures. Consult your local building department.

Install the collectors as described in the Seamed Metal Roof Mounting instructions.

The most important structural consideration is to securely anchor the solar collector and the mounting hardware to the

BASIC TOOLS AND MATERIALS

Tape Measure
 Chalk Line
 Torque Wrench (Inch Pounds)
 Level
 Pliers
 8" & 10" Adjustable Wrenches
 7/16", 9/16", & 16mm Wrenches
 Ratchet

7/16", 9/16", & 16mm Sockets
 6' x 8' or 6' x 10' Tarp (1 per collector)
 3/16" Allen Wrench

Installation Hardware (Supplied):
 Includes:
 • Hardware
 • Mounting Brackets

SEAMED METAL ROOF MOUNTING

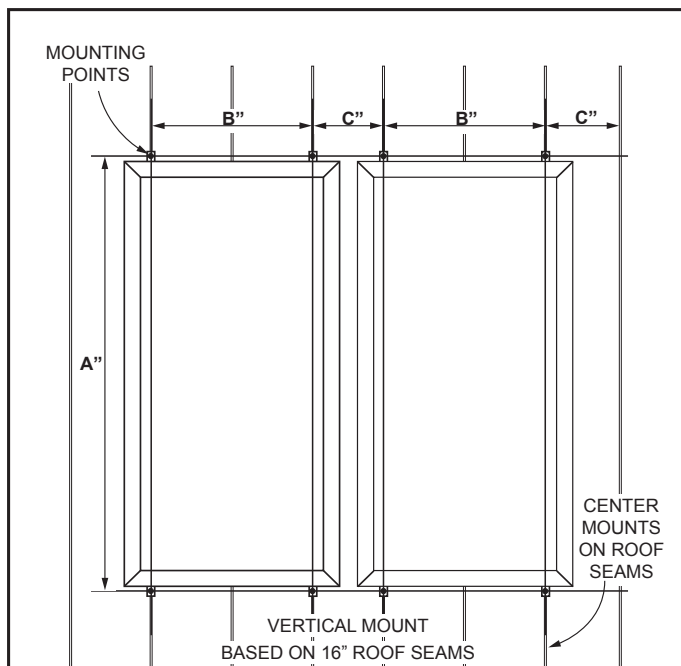

Figure 1.

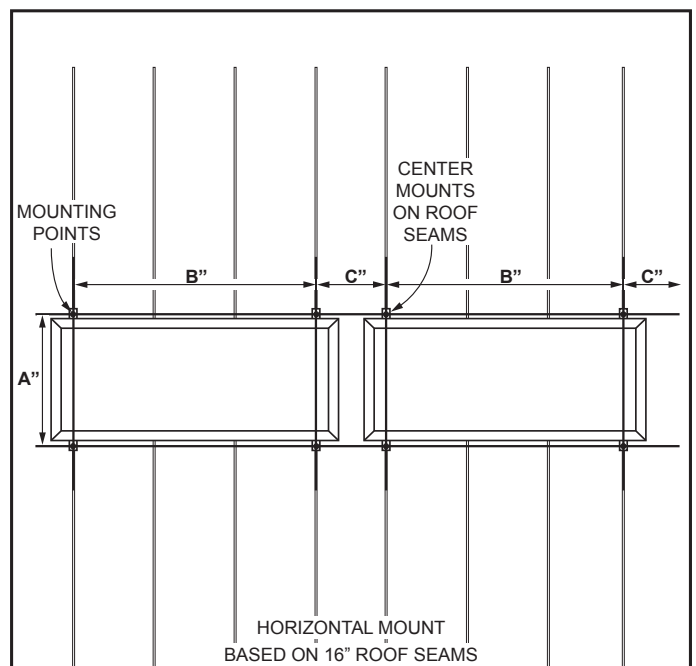

Figure 2.

NOTICE

* IF MOUNTING WITH AN OPTIONAL TILT MOUNT KIT, FOR OPTIMAL COLLECTOR ANGLE REFER TO ITS INSTRUCTION SHEET FOR THE APPLICABLE "A" DIMENSION.

** DIMENSION DEPENDANT ON ROOF SEAM SPAN.

COLLECTOR	A	B	C
Vert. 3.5' X 7'	86*	32**	16**
Vert. 4' X 8'	97*	32**	16**
Vert. 4' X 10'	121*	32**	16**
Horiz. 3.5' X 7'	42.25*	64**	32**
Horiz. 4' X 8'	47*	64**	48**
Horiz. 4' X 10'	47*	96**	32**

Table 1.

1. Determine roof layout. See Figure 1 for vertical mounting, Figure 2 for horizontal mounting, and Table 1.
2. Determine on what type of metal roof the mounting brackets will be used.
 - A. For horizontal seam applications, the setscrews must be accessible from the top for tightening. See Figure 3.
 - B. For snap-together type seams, the set screws are located opposite the open (or overlap) side of the seam. See Figure 4.



Figure 3.

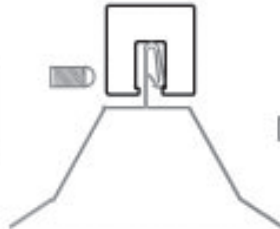

Figure 4.

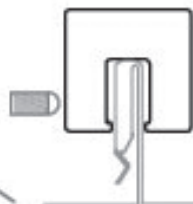

Figure 5.

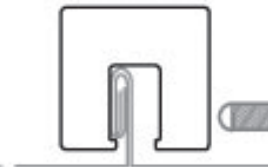

Figure 6.

C. On some seams, the clamp orientation is not critical. See Figure 5.

D. For machine-folded seams the clamps are to engage the seam. See Figure 6.

Ensure the bolt hole is in the desired orientation and that the setscrews are on the correct side of the seam. See Figures 3-6.

3. Layout the roof as specified in Figure 1 for vertical mounting, Figure 2 for horizontal mounting, and Table 1.
4. Note that the bolt hole in the mounting clamp should be located at the position where the 5/16" hole is normally located. Drill holes are not required for this application. See Figures 1 & 2.
5. Once the mounting position has been determined, position the mounting clamp appropriately on the panel seam per step 2. Both setscrews should be in the same side of the mounting clamp. Be sure the mounting bolt hole is in the correct position for mounting the solar collectors.
6. Torque the setscrew tension between 160 and 180 inch pounds for 22 ga steel and between 130 and 150 inch pounds for 24 ga and thinner gauges of steel.
7. Install the solar collector mounting bracket to the mounting clamp as shown in Figure 7. Use the M10-1.25 bolt included with the mounting clamp. See Figure 7 for general component locations.
8. Repeat steps 3-7 for the remainder of the mounting bracket locations.

ATTACHING COLLECTOR TO MOUNTING BRACKETS

Once all of the mounting brackets have been secured to the roof the solar collector(s) can be installed. See Figure 7 for these instructions.

1. Insert the stainless steel channel nut w/spring inside of the mounting bracket.
2. Fasten the solar collector mounting clip to the channel nut with the stainless steel bolt, lock-washer, and flat washer as shown. Do not tighten. Repeat step for the other mounting bracket locations.
3. The solar collector can now be set on the mounting brackets. To aid in handling the collectors on the roof the mounting clips may be tightened to the lower mounting brackets prior to raising the collectors. The

collector can then be set on the lower mounting brackets while the top clips are fastened over the lip on the collector frame.

4. After the solar collector is in position, locate the upper mounting clip so that its lip over-hangs the lip of the solar collector frame as shown. Tighten the mounting clip to the solar collector frame securely. Repeat for the other upper mounting clips.
5. Once the upper mounting clips are secured, the bottom mounting clips can be loosened and retightened over the collector lip as directed in step 4.
6. Repeat steps as needed for other solar collectors.

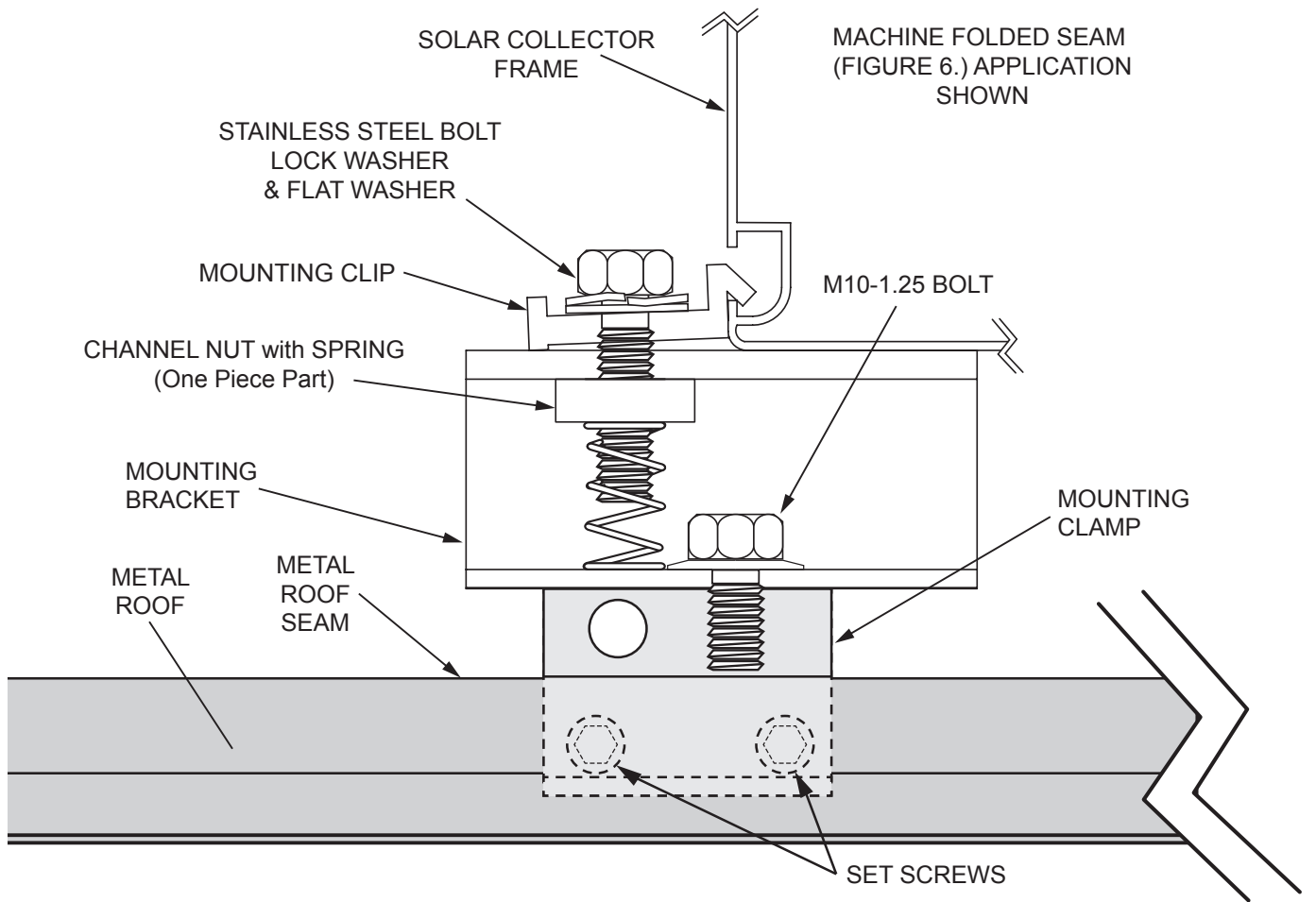

Figure 7.