



**SCT-199 - TWO WATER HEATERS, DIRECT PLUMBING WITH NO RECIRCULATION**

**WARNING:** THIS DRAWING SHOWS SUGGESTED PIPING CONFIGURATION AND OTHER DEVICES; CHECK WITH LOCAL CODES AND ORDINANCES FOR ADDITIONAL REQUIREMENTS.

DRAWING SHOWS INDOOR UNITS. OUTDOOR UNITS ARE PIPED IN THE SAME MANNER.

**LEGEND**

	TEMPERATURE & PRESSURE RELIEF VALVE		FULL PORT BALL VALVE	----	COLD
	PRESSURE RELIEF VALVE		TEMPERATURE GAGE	----	HOT
	CIRCULATING PUMP		CHECK VALVE	----	BUILDING RETURN
	TEMPERATURE CONTROL PROBE		WATER FLOW SWITCH	----	GAS
	DRAIN				

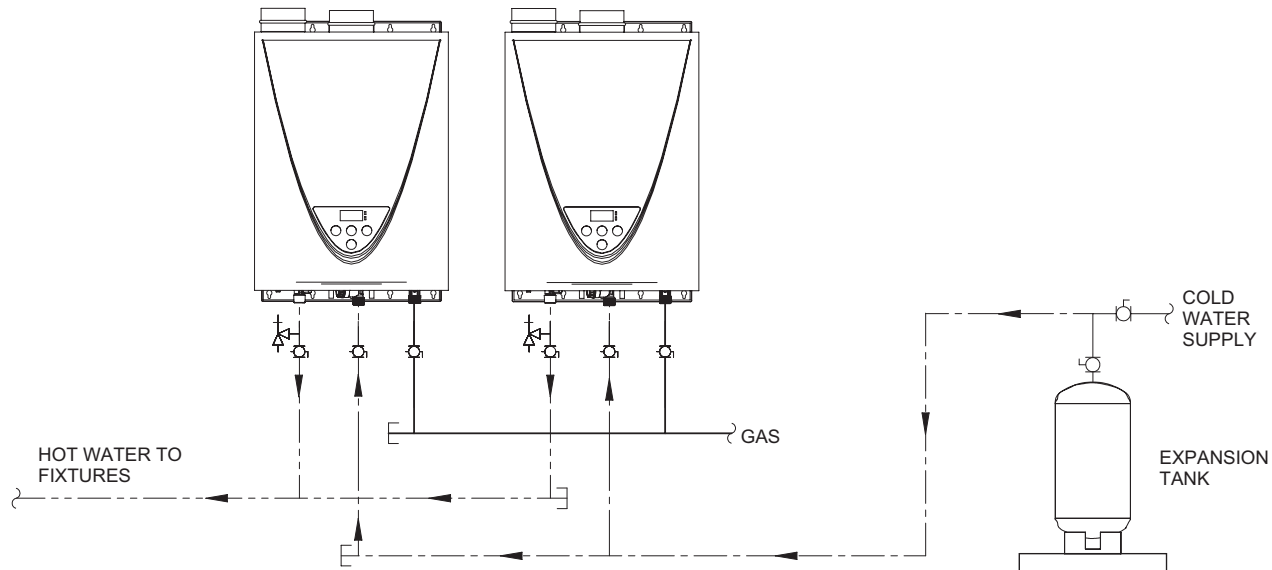

**NOTES:**

1. Installation of a device to minimize scale deposits, such as the Product Preservers®, water softener, etc. should be considered. Refer to the heater's installation manual for additional information and/or consult with a local water quality expert.
2. Gas supply line shall be sized per the heater's installation manual and the current edition of ANSI Z223.1/NFPA 54.