



# COMMERCIAL-GRADE

## Residential Electric Water Heaters

### PREMIER® HYBRID 80-GALLON ELECTRIC HEAT PUMP WATER HEATER

The Premier® Hybrid Electric heat pump water heater from State Water Heaters is the most cost effective energy-efficient option available for consumers who want to save money on their utility bills. The Premier® Hybrid Electric heat pump can reduce water heating costs up to 58% and provide payback in 2-3 years. With annual savings of \$242 or more for the life of the appliance there is no better way to go green than the Premier® Hybrid Electric heat pump.

#### HOW DO THEY WORK?

Absorb ambient heat from the surrounding air to heat water using a compressor and “Environmentally-Friendly” R134a refrigerant

- Self-contained heat pump unit is integrated into the top of the tank
- Multiple operating modes to maximize efficiency and performance

#### QUALIFIES FOR MANY STATE AND LOCAL UTILITY REBATES - CHECK WWW.DSIREUSA.ORG

#### INCREASED STORAGE

- High capacity storage tank enables the heat pump to operate more frequently than
- the heating elements. This provides higher energy efficiency and lower operating costs, saving more money than lower capacity units
- High capacity storage tank provides more hot water for peak demand periods

#### ENERGY EFFICIENCY

- Up to a 2.20 Uniform Energy Factor (UEF) Rating conserves energy and meets ENERGY STAR® qualifications

#### CHOICE OF OPERATING MODES

- Select from Efficiency, Hybrid, or Electric modes to match heating requirements to environmental conditions. Hybrid mode automatically adjusts between compressor and element, depending upon heat requirements. Vacation mode reduces operating costs and provides freeze protection during extended absence

#### BACKUP ELECTRIC ELEMENTS

- Long-lasting incoloy heating elements, 240V/2000W lower and 240V/4500W upper, helps heat water when in conventional Electric or Hybrid modes

#### DRY FIRE PROTECTION

- Control system checks to ensure the tank is full of water during start up to prevent dry firing the heating elements

#### ELECTRONIC USER INTERFACE

- User-friendly LCD touch pad control with plain English text and intuitive status icons provides easy interaction

- Large LCD temperature display (see back) shows temperature in °F or °C
- 3 line 13 character backlit LCD display communicates current set point, status and operational information
- Advanced diagnostics convey error messages in plain English. The last four error messages are saved in the control system memory.
- Child resistant safety lock deters unwanted access to temperature settings

#### POWERED ANODE

- \$230 value - after market accessory
- Lasts for the life of the water heater
- Maintenance free - reduces service/maintenance costs
- Eliminates smelly and discolored water problems associated with standard anodes

#### OTHER FEATURES

- Ideal for basements or garage installations; the compressor transfers heat to the water while dehumidifying and cooling the ambient air
- Washable air filter is easily removed for routine cleaning

#### ACCESSORY INLET/OUTLET DUCT KITS

- Permits installation in confined spaces as small as 4' x 4' x 8' (128 cubic feet)
- Duct adaptor kits redirect inlet and/or outlet air
- Engineered solution – ensures optimal efficiency performance

#### 10-YEAR YEAR LIMITED WARRANTY

- For complete information, consult written warranty or go to [statewaterheaters.com](http://statewaterheaters.com).



# SOLID. STATE.



# COMMERCIAL-GRADE

## Residential Electric Water Heaters

Model Number	Nominal Capacity	Rated Storage Volume	UEF	First Hour Rating (Gallons)	Dimensions in Inches					Approx. Shipping Weight (lbs)
					A	B	C	D	E	
EPX 80 DHPT	80	77	2.20	73	82-1/2	24-1/2	55	4-1/4	56-1/3	340



### ELECTRONIC USER INTERFACE

- Large LCD touch pad display
- Intuitive icons clearly indicate the current operating mode
- Individual backlit buttons for mode selection:

### EFFICIENCY HYBRID ELECTRIC VACATION

- Three-line display communicates current status and displays error messages in plain English when applicable
- Safety lock

### EFFICIENCY MODE

- Utilizes the heat pump for all water heating
- Automatically reverts to heating element if ambient air or water temperatures are outside optimal operating range for heat pump

### HYBRID MODE

- Utilizes the heat pump or heating element, depending on demand

### ELECTRIC MODE

- Standard electric water heater operation

### VACATION MODE

- One touch operation maintains tank temperature of 60°F (15.6°C) during vacation or extended absence to reduce operating costs and provide freeze protection

### OTHER FEATURES:

- Powered anode to protect against tank corrosion (Max 50 mA draw)
- 2 Inch "Environmentally-Friendly" non-CFC foam insulation
- Coefficient of performance (COP) 3.1
- Child resistant brass drain valve
- CSA certified and ASME rated T&P relief valve
- Water temperature set point range; 95°F to 150°F (35°C to 66°C)

### OPTIONAL ACCESSORIES:

- Inlet Air Duct Kit part number 100131277
- Outlet Air Duct Kit part number 100131278

### OPERATING REQUIREMENTS:

- Requires provision for condensate draining; if a suitable drain is not available, a condensate pump is required
- Minimum 750 cubic feet of space without duct kit, minimum 128 cubic feet of space with duct kit
- 240 VAC single phase 30 amp power supply

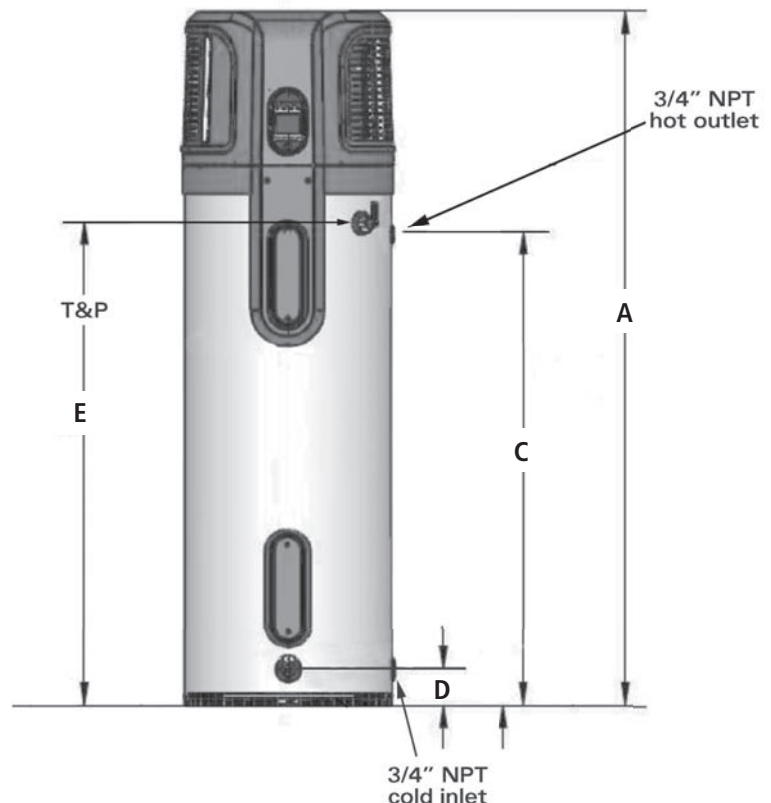

FOR MORE INFORMATION ON CALL 1-800-365-0024. STATE WATER HEATERS RESERVES THE RIGHT TO MAKE PRODUCT CHANGES OR IMPROVEMENTS WITHOUT PRIOR NOTICE.