

MAINE HOMEOWNERS

Electrify Your Home with Heat Pump Water Heaters to Cut Operating Costs and Carbon Emissions



What is Building Electrification?

Building electrification refers to the transition from relying on gas-fired appliances in the home and replacing them with electric alternatives. In doing so, homes will become safer, more efficient, as well as help avoid emitting more carbon emissions into the environment.



Water Heating Energy Usage

Water heaters are the second highest source of energy usage in the home, contributing to as much as 30% of a household's energy cost. On average, water heaters use more energy than a refrigerator, dishwasher, clothes washer and dryer combined. Switching to a high efficiency heat pump vs. a standard gas or electric water heater means significantly lower energy bills, fewer carbon emissions, upfront and long-term savings, and plenty of hot water. Learn more about how you can do your part to reduce your carbon emissions, while reaping the benefit of energy savings.



How Heat Pump Technology Works

Electric heat pump water heaters use warmth from the surrounding air to heat your water. Like air conditioners in reverse, heat is pulled into the storage tank from the surrounding air, helping cool and dehumidify the room in the process. In hybrid mode, when fast recovery is needed, two back-up 4,500-watt copper heating elements heat the water during peak demand periods.

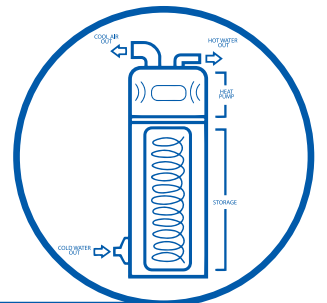

Heat Pumps—up to 5X More Efficient Than Standard Electric or Gas Water Heaters

State Hybrid Electric Heat Pump water heaters are up to 5X* more efficient than standard gas or electric water heaters. Reduce carbon emissions by up to 4X** and save energy by replacing your conventional gas or electric with an electric heat pump water heater.



SAVE UP TO 5X IN ENERGY COSTS AVOID UP TO 4X IN CO₂ EMISSIONS

MAINE OPERATING COSTS & EMISSIONS BY PRODUCT TYPE

10 Year Period Shown Below

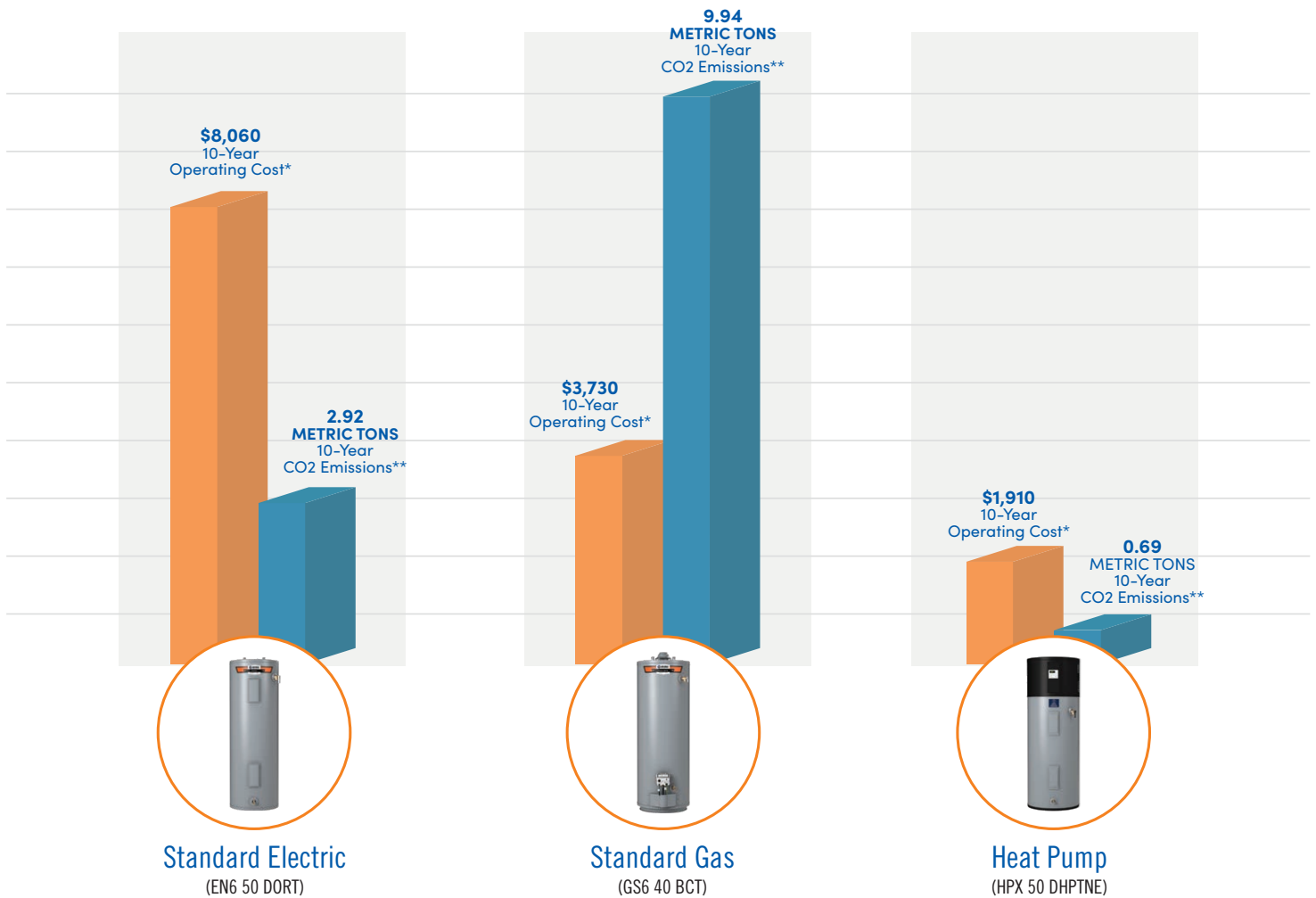

* Based on DOE test procedure and Energy Guide comparison of 50-gallon nominal capacity pre-2015 standard electric (using DOE EF to UEF conversion rates), State 40-gallon nominal capacity standard gas model GS6-40 and State 50-gallon Premier® AL heat pump water heaters. Annual energy cost based on \$21.93 per thousand cubic feet natural gas and residential electricity cost of 23.66 cents/kWh in Maine. Source accessed February 2023: https://www.eia.gov/dnav/ng/ng_sum_lsum_a_EPG0_PRS_DMcf_m.htm
Source accessed February 2023: https://www.eia.gov/electricity/monthly/epm_table_grapher.php?t=epmt_5_06_a

**Sources for the CO₂ emission calculations: <https://www.nrel.gov/buildings/end-use-load-profiles.html>; <https://www.eia.gov/electricity/state/maine/>