



COMMERCIAL-GRADE RESIDENTIAL TANKLESS WATER HEATERS

NON-CONDENSING CONCENTRIC VENT

Fully modulating, gas fired, tankless water heater with sealed combustion and power vented flue. Supplies hot water to domestic hot water systems and can be used with water storage tanks, recirculation systems, and/or combined domestic & heating applications.

FEATURES:

CONCENTRIC VENT DESIGN

FIELD CONVERTIBLE FROM NATURAL GAS TO PROPANE

COMPLIES WITH SCAQMD RULE 1146.2 AND OTHER AIR QUALITY MANAGEMENT DISTRICTS WITH SIMILAR NO_x EMISSION REQUIREMENTS OF 14 NG/J OR 20 PPM

MAXIMUM FLOW RATES UP TO 10.0 GPM

COPPER HEAT EXCHANGER

- 25x better heat transfer than stainless steel thus stabilizing outgoing water temperature quicker and reducing pressure drop across the heat exchanger

INDOOR MODELS ONLY

GTS-510C CAN BE USED IN BOTH RESIDENTIAL AND COMMERCIAL APPLICATIONS

- Easy-Link up to 4 units (no additional parts or accessories needed)
- Multi-link up to 20 units

COMPLIES WITH LEAD FREE STANDARDS

SAFETY FEATURES:

- Built-in Freeze Protection
- Manual Reset Hi-Limit (Up to 194°F)
- Overheat Cutoff Fuse
- Inlet and Outlet Thermistors for Constant Temperature Monitoring
- Air Fuel Ratio Rod
- Flame Sensor

VENTING AND COMBUSTION

- Direct vent APNC35 concentric vent system
- Vertical or Horizontal Vent Termination Installation
- 43' Max Length, 4 Elbows max (87° elbows = 5' equivalent length)
- Power Direct Vent
- Electronic Ignition - No Pilot Light

OPTIONAL ACCESSORIES

- Isolation Valve Kit
- Remote Control
- Product Preserver
- Multi-Unit Controller (510C model only)

WARRANTY

- 15-year limited warranty on heat exchanger in residential applications
- 5-year limited warranty on heat exchanger in commercial applications
- 5-year limited warranty on all parts
- 1-year labor coverage for warranty repairs

INDOOR MODELS

GTS-310C, GTS-510C



(510C models only)



ANSI Z21.10.3

SOLID. STATE.



COMMERCIAL-GRADE RESIDENTIAL TANKLESS WATER HEATERS

Model Number	Type*	Gas Consumption Input		Inlet Gas Pressure**		UEF	Maximum GPM***	Hot/Cold Connections	Gas Connection	Dimensions in Inches			Approx Shipping Weight (lbs)
		Minimum BTU/H	Maximum BTU/H	Minimum in. W.C.	Maximum in. W.C.					Height	Width	Depth	
GTS-310C-NI	Natural	15,000	190,000	4.0	10.5	0.81	8	3/4" NPT	3/4" NPT	20-1/2	13-3/4	11-1/2	55
GTS-510C-NI+	Natural	15,000	199,000	4.0	10.5	0.81	10	3/4" NPT	3/4" NPT	20-1/2	13-3/4	11-1/2	55

15-150 psi water pressure. 40 psi or above recommended for maximum flow.

*Field gas convertible from natural gas to propane. Conversion kit is included with the heater.

**For Propane, minimum inlet gas pressure is 8.0 in. W.C. and maximum inlet gas pressure is 14.0 in. W.C.

***Current numbers based on factory testing; 0.5 GPM required for activation; 0.4 GPM required for continuous fire after initial ignition.

+Suitable for commercial applications.

Certified from sea level to 10,100 ft. elevations.

INDOOR MODEL DIMENSIONS

CLEARANCES: TOP 12", BOTTOM 12", FRONT 4", BACK .5", SIDES 3"

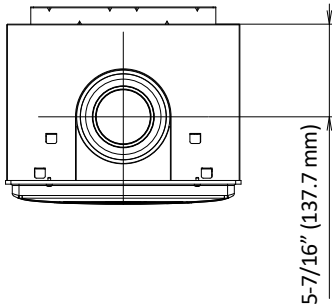

Top view

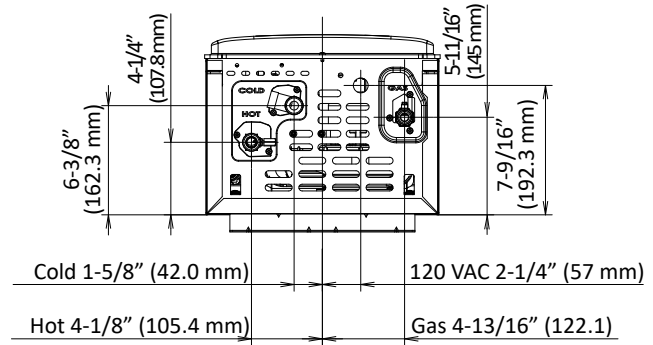

Bottom view

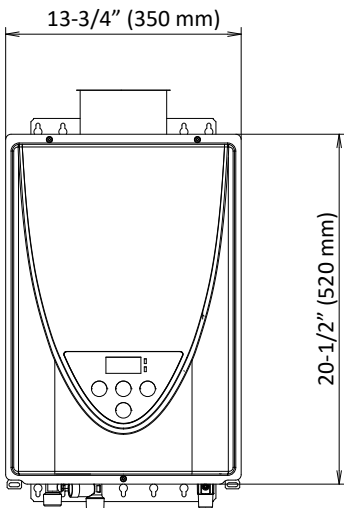

Front view

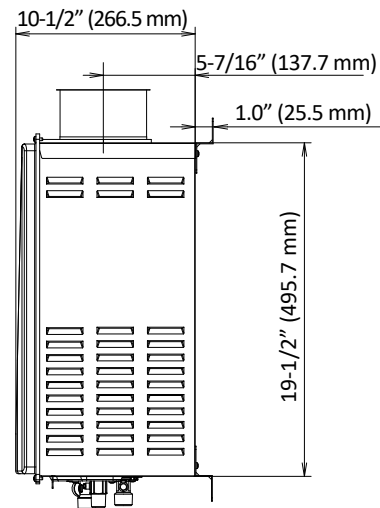

Side view

310C MODEL

310C: Flow Rate vs. Temperature Rise

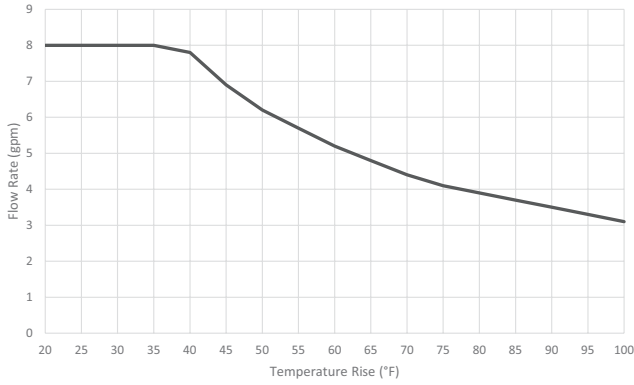

310C Pressure Drop

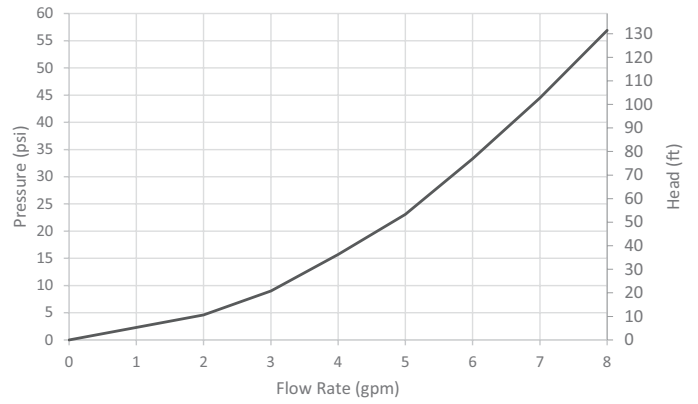

Tolerance is within ± 10%

510C MODEL

510C: Flow Rate vs. Temperature Rise

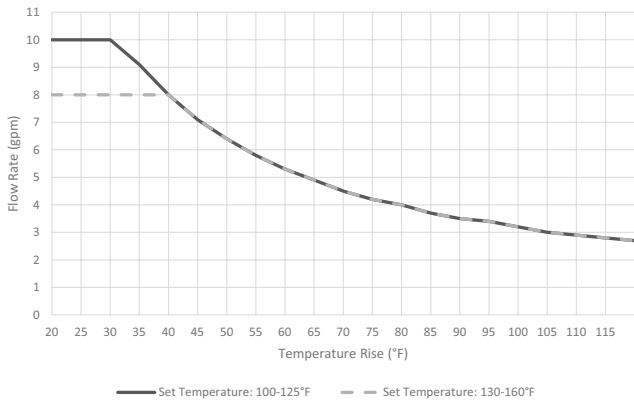

— Set Temperature: 100-125°F - - - Set Temperature: 130-160°F

510C Pressure Drop

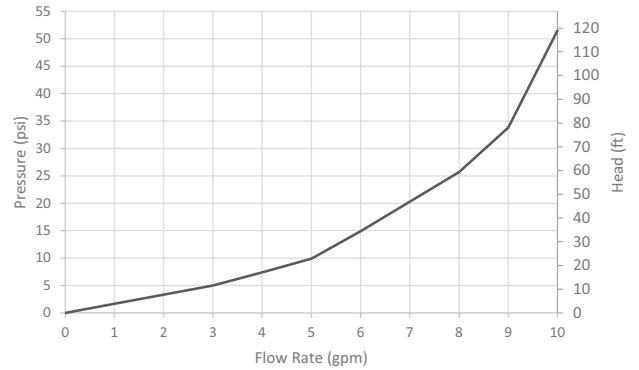

Tolerance is within ± 10%. Max flow is 8 gpm when set temp above 125 °F



SUGGESTED SPECIFICATIONS FOR THE GTS-510C-NI

The fully modulating, on-demand, non-condensing gas fired tankless water heater shall be State Water Heater model GTS-510C-NI, having a maximum input rating of 199,000 Btu/h and available in natural gas (NG). For use with propane (LP) gas, the heater shall be field converted using the factory supplied conversion kit. The conversion kit shall be supplied with the heater. The heater shall have $\frac{3}{4}$ in. male NPT water and gas connections. The inlet gas supply pressures shall be 4.0 in. WC (min.) up to 10.5 in. WC (max) for NG and 8.0 in. WC (min.) up to 14 in. WC (max.) for LP. The heater shall incorporate an integrated temperature controller that will provide diagnostic information, fault history, and heater set temperature. The heater shall operate using 120 V / 60 Hz power source. The heater will incorporate a factory installed power cord.

The indoor heater shall be vented with a 3 $\frac{1}{2}$ " direct vent APNC35 concentric vent with a length not to exceed 43 ft. (equivalent), terminating horizontally or vertically with no more than four 87° elbows.

The water heater shall use a commercial grade copper alloy, fin tube heat exchanger with quick release brass or bronze waterways. The heater shall be controlled by an onboard solid-state printed circuit board which uses the following factory installed components: thermistors to monitor water temperature; a flow sensor to measure flow rate; a flame sensor to monitor combustion; and an air-fuel ratio rod to measure and adjust air input in order to maintain optimal combustion efficiency. The heater also consists of inline fusing and surge absorbers for electrical surge protection, an electronic spark igniter, aluminized stainless steel burners, hi-limit switch to monitor water temperature, modulating gas valve, overheat cutoff fuse, and dual freeze protection that incorporates heating blocks and the ability to automatically fire the heater to protect the heat exchanger.

The heater can manifold to Easy-Link up to 4 heaters to provide additional capacity. The Easy-Link controls shall be built onto the onboard solid-state printed circuit board and does not require external controls. The linking control wire shall be supplied with the heater. A Multi-Unit controller, 100112691, can manifold 5-20 heaters. The Easy-Link and Multi-Unit Controller shall modulate the system for the most efficient performance. The Easy-Link and Multi-Unit Controller shall rotate the priority heater every 12 hours of operation time or 100 starts for balanced duty/cycle operation.

The heater models are design certified by CSA according to ANSI Z21.10.3, approved for sale in the United States, meets the energy efficiency requirements of the U. S. Department of Energy and ASHRAE 90.1, complies with SCAQMD Rule 1146.2 and other air quality districts with similar requirements for low NOx emissions of 14 ng/J or 20 ppm, and shall be certified to NSF 5 Standards.