

SERVICE HANDBOOK FOR STANDARD RESIDENTIAL ELECTRIC WATER HEATERS



Printed in the USA 0804
\$15.00

320990-000

This service handbook addresses service issues associated with Standard Residential Electric Water Heaters.

RESIDENTIAL ELECTRIC WATER HEATER SERVICE HANDBOOK

TABLE OF CONTENTS

	Page		Page
Introduction			
Certification and Approval.....	1	A-9 Off Peak Circuit.....	18
Tools	2	A-9 Circuit Sequence of Oper.....	19
Terms, Definitions, Formulas.....	2	Three phase unbalanced circuit	20
Residential Electric Water Heaters		A-9 Circuit Testing	21
Installation.....	4	Miscellaneous Information.....	24
Construction.....	7		
Element Test - continuity	8	Service Bulletins	25
Element Test - grounded	9		
Element Test - amperage.....	10		
Field Wiring.....	12		
Thermostats.....	13		
C-2 Circuit & Sequence of Operation	14		
C-2 Circuit Testing.....	15		
A-6 Circuit and Wiring.....	16		
A-6 Sequence of Operation	17		

RESIDENTIAL ELECTRIC HANDBOOK INTRODUCTION

This service handbook is designed to aid in servicing and troubleshooting Residential Electric water heaters in the field. No duplication or reproduction of this book may be made without the express written authorization of the manufacturer.

The following text and illustrations will provide you with a step-by-step procedure to verify proper installation, operation, and troubleshooting procedures. Additional quick reference data is included to assist you in servicing this product.

The information contained in this handbook is designed to answer commonly faced situations encountered in the operation of the Residential Electric product line and is not meant to be all-inclusive. If you are experiencing a problem not covered in this handbook, please contact the Information Center at 1-800-365-0024 or your local distributor for further assistance. This handbook is intended for use by licensed plumbing professionals and reference should be made to the instructional manual accompanying the product.

CERTIFICATIONS AND APPROVALS

Code Compliance - All models meet or exceed federal minimum energy standards effective January 20, 2004, according to latest editions of the National Appliance Energy Conservation Act (NAECA). They also comply with the latest editions of the B.O.C.A. National Codes, C.E.C., U.B.C., S.B.C.C., C.A.B.O. and the H.U.D. standards. All models U.L. Listed according to safety specifications outlined in Underwriters' Laboratories, Inc. Standards for Safety (U.L. 174).

RESIDENTIAL ELECTRIC WATER HEATER SERVICE HANDBOOK

GENERAL SECTION

TOOLS REQUIRED: FOR SERVICING RESIDENTIAL ELECTRIC MODELS

- #2 Phillips screw driver
- electrical multi-meter (volt/Ohm)
- water pressure gauge (with a lazy hand)
- thermometer
- hose – to drain tank
- container – to measure gallons per minute flow
- 1 1/16 inch – 6 point – socket (for anode removal)
- 1 1/2 inch deep socket or a manufacturer's element wrench
- Amp meter- clamp type

TERMS, DEFINITIONS, AND FORMULAS:

Draw efficiency is the quantity of hot water available to the consumer before the outlet water temperature decreases 25 degrees F. A 40 gallon water heater will typically provide 70% (28 gallons) of this “usable” hot water. The burner or elements are allowed to operate during this test. Incoming, cold water mixes the remaining stored water below this 25 degree limitation.

Energy Factor is an indicator of the combined thermal efficiency and standby efficiency of a water heater. The higher the energy factor, the more efficient the water heater will be.

Recovery rate is the amount of water that is heated to a set temperature, per hour. An example might be that a water heater has a recovery rate of 30 gallons of water per hour at 80 degree F. (Fahrenheit) temperature rise.

Temperature rise is the increase in the temperature from its coldest “inlet” water temperature to the desired hot (outlet) setting. Typically this is assumed to be 40 degrees entering water; 120 degrees desired stored water or 80 degrees “temperature rise.”

Standby efficiency is the water heater's ability to contain heat in the tank. A minimum of tank water heat loss per hour is desired.

Water (for all practical purposes) cannot be compressed.

RESIDENTIAL ELECTRIC WATER HEATER SERVICE HANDBOOK

GENERAL SECTION – cont'd.

TERMS, DEFINITIONS, AND FORMULAS:

Water Expands when it is heated. Volume increases about 2% from 40° to 140° F.

Minerals and gases will separate from water as temperature increases

Amperage (Amps) (1 phase) = **Watts** divided by Volts (Ohm's Law)

KW Required = (GPH X 8.25 X Temp. Rise X 1.0) divided by (3413)

Ohms = Volts divided by Amperes (Ohm's Law)

One kilowatt is equal to 1000 watts

One kilowatt is equal to 3,413 BTU

Recovery Rate = (KW X 3413) divided by (Temp. Rise X 8.25)

Rise (F°) = (KW X 3413) divided by (GPH X 8.25)

Supply electrical fusing or breakers should be sized at least 125% of expected heater amperage.

Water weighs 8.25 pounds per gallon at 120°F (49°C).

% of Hot water = (Mixed temp. – Cold) divided by (Hot temp. – Cold). This formula gives the number of gallons drawn from the water heater for each gallon delivered at a shower head or faucet. If the shower head flow rate (gallons per minute) is known, the **draw efficiency and gallon capacity** of the water heater may be used to calculate the length of the showering period in minutes.

Watt Density = the density of the wattage output of the element compared to the surface area of the element (i.e. "High Watt Density Element" will have the most wattage per square inch of element surface)

Energy Factor:

Formula: The minimum EF allowed = .97 - .0019 x V (volume of storage)

Example: Volume (50 gal.) x .0019 = .095 gal.x.97 - .095 = .875 (minimum energy factor).

Note: Since the formula varies by volume, each tank size will have a different minimum energy factor requirement.

The formula for **gas water heaters** is different than the above example.

RESIDENTIAL ELECTRIC WATER HEATER SERVICE HANDBOOK

INSTALLATION - typical

SOME MODELS MAY HAVE SIDE OR REAR CONNECTIONS

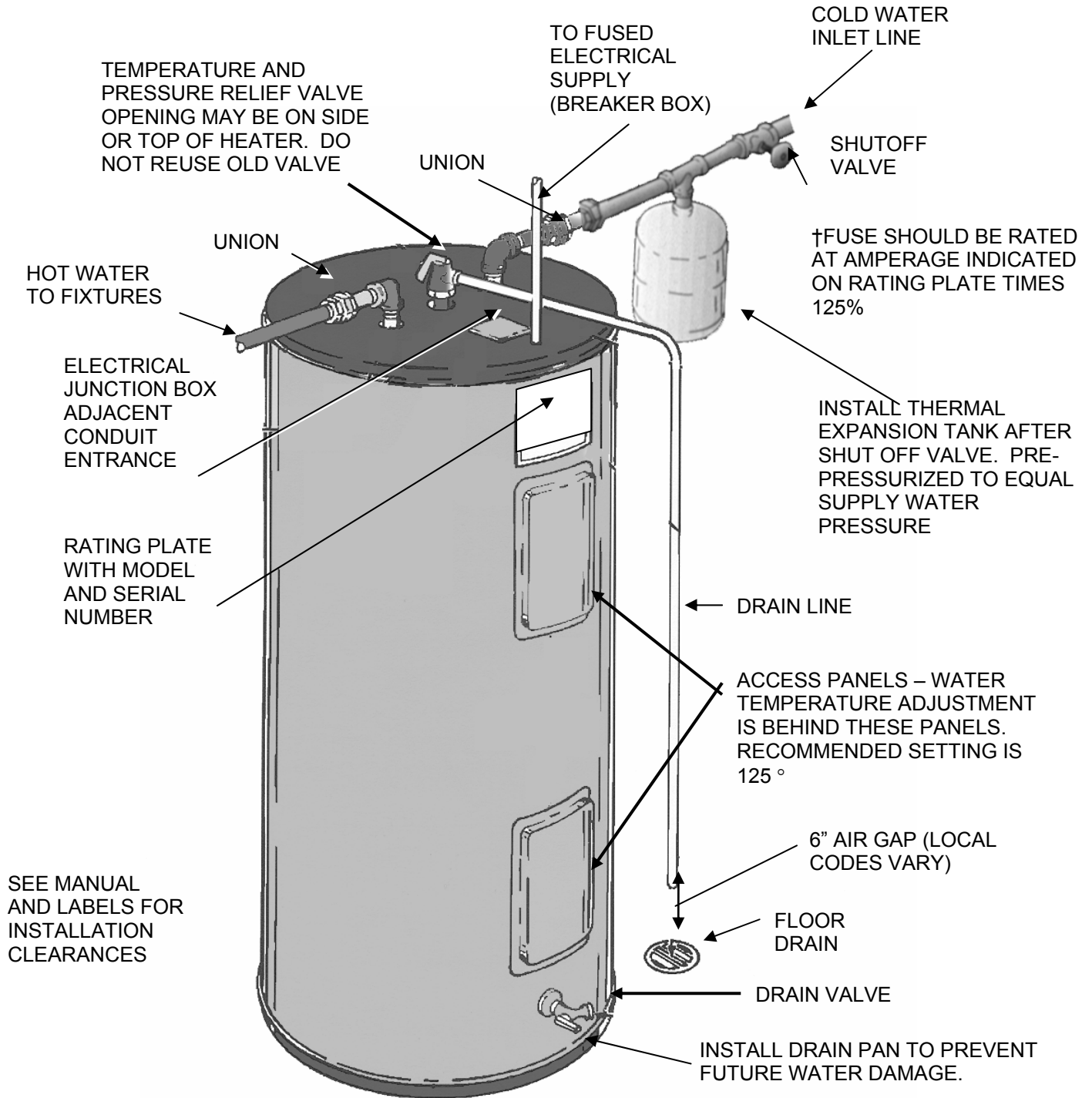

INSTALLATION MUST FOLLOW LOCAL CODES AND INSTRUCTION MANUAL GUIDELINES.

RESIDENTIAL ELECTRIC WATER HEATER SERVICE HANDBOOK

INSTALLATION - typical

Parallel Piping arrangement for multiple water heaters ensures maximum hot water and efficient operation.

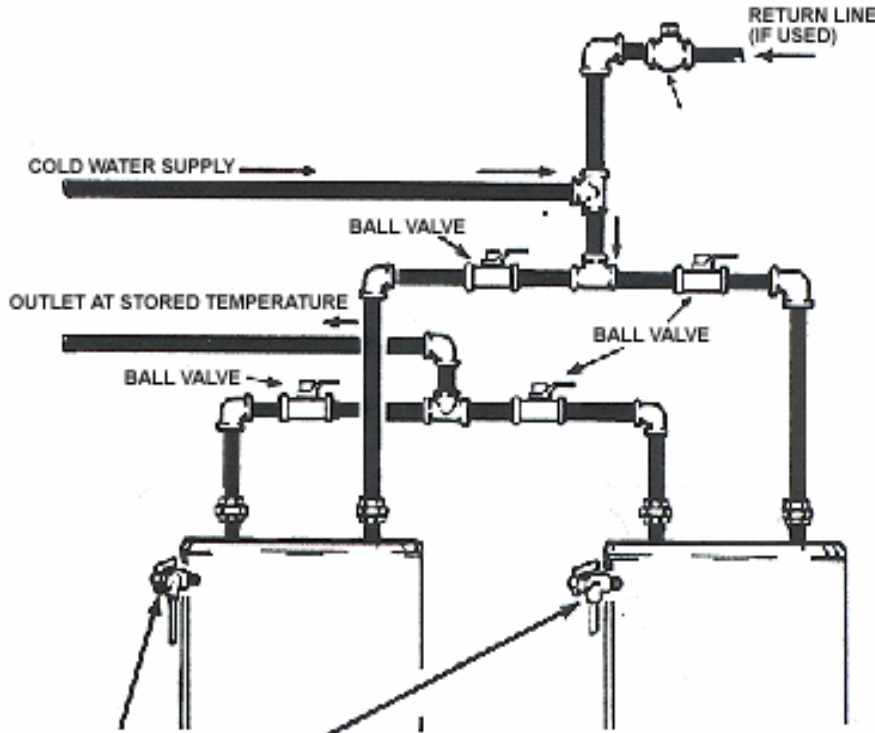

This piping arrangement depends on dividing piping between water heaters evenly. It may be expanded for more than two water heaters. Pipe size may need to increase if more water heaters are added to improve water flow for larger applications.

This balanced piping system is preferred instead of a series piping system where one water heater feeds heated water to the cold inlet of the second water heater. A series arrangement does not deliver hot water as quickly or in as great an amount as a parallel piping arrangement.

INSERT A

INSTALL THERMAL EXPANSION TANK ON COLD WATER SUPPLY LINE, IF CHECK VALVE OR PRESSURE REDUCING VALVE IS USED IN SUPPLY.

Expansion tanks may be required by local code. Water expands by about 2% of its volume as it is heated from 40°F. to 140°F. The expansion created in a 40 gallon water heater would be about 8/10 of a gallon.

A 2 gallon expansion tank will absorb this amount of expansion. For larger applications consult the tank manufacturers sizing information.

RESIDENTIAL ELECTRIC WATER HEATER SERVICE HANDBOOK

CONSTRUCTION - typical

This portion of this manual applies to the Operation and Servicing of Residential Electric, Tank Type, Water Heaters. The illustrations are for two element models but the information also applies to single element models.

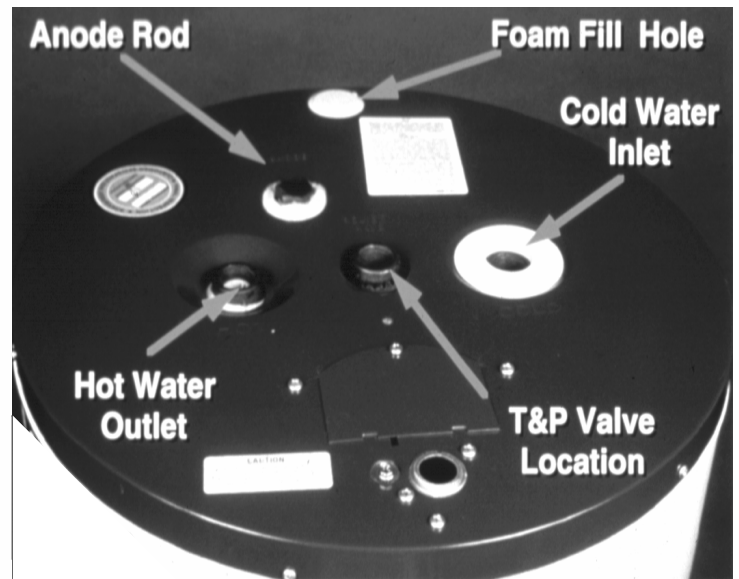
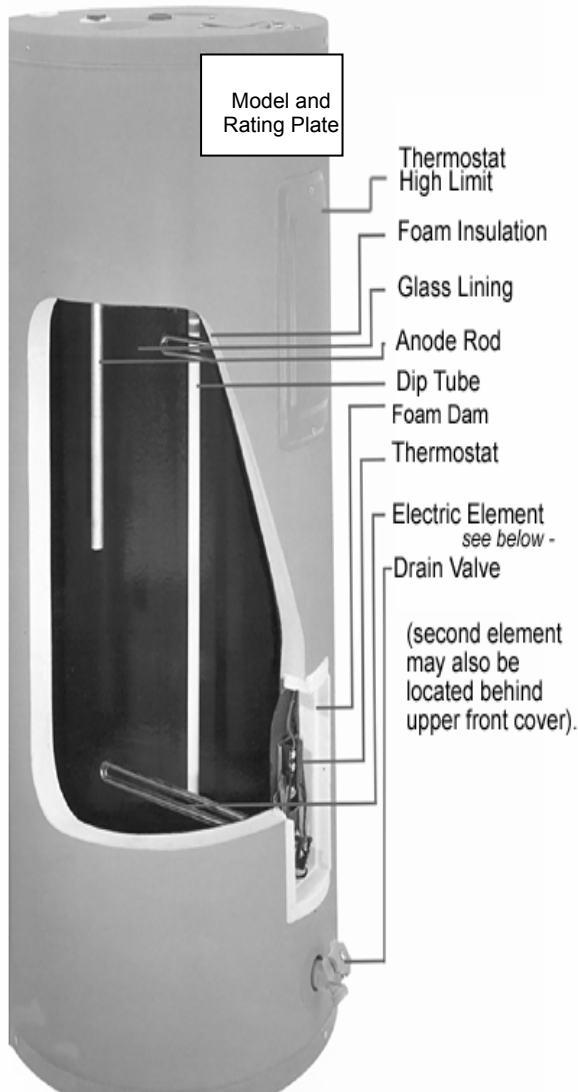

RESIDENTIAL ELECTRIC WATER HEATER SERVICE HANDBOOK

Construction – cont'd.

Heating element(s)

This style water heater will have one or two electric, heating elements immersed in the tank. One element will always be located low in the tank; a second element is commonly located down about 1/3 of the tank height from the top of the tank. These elements will not operate at the same time unless the water heater was ordered with a simultaneous wiring system. If they operate at the same time, amperage draw doubles, wire gauge size increases, fuse size increases and little is gained in heat recovery.

1 KW	Temperature Rise					
	80	90	100	110	120	130
Gallons Per Hour	5.2	4.6	4.1	3.8	3.5	3.2

Residential Electric – continued

Since the element's heating area is totally immersed in the tank, thermal efficiency is assumed to be 100%. All of the heat generated by the element enters the water.

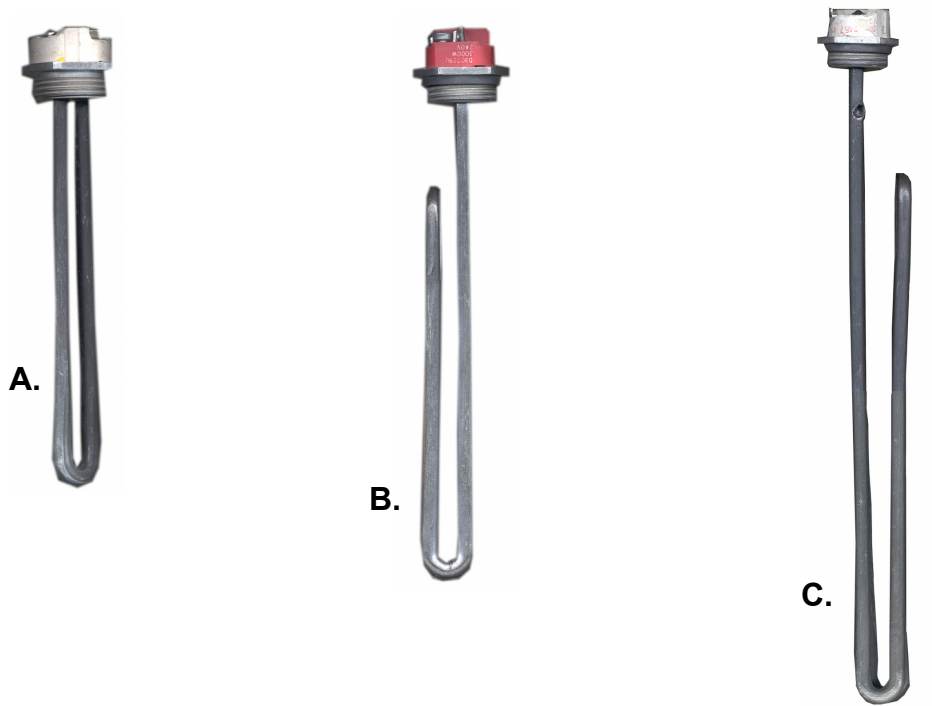

Watt Density = the density of the wattage output of the element compared to the surface area of the element (i.e. "High Watt Density Element" will have the most wattage per square inch of element surface. If the above elements generated 4,500 w. each, "A" might be considered a "high" watt density element, "B" a medium and "C" a low.)

RESIDENTIAL ELECTRIC WATER HEATER SERVICE HANDBOOK

ELEMENT TEST – RESISTANCE/CONTINUITY

OHMS Resistance Check**

Disconnect wires from the element terminals.

NOTE: OHM readings may vary by up to 7.5% depending on the meter and the element. Always check meter for proper operation by touching probe ends together.

Test Conditions:

This test uses the multi-meter's battery as the electrical supply.

Procedures:

- Power to the water heater is "OFF".
- Multi-meter set to OHMS scale testing.
- Black lead "Common" port.
- Red lead in "Ω" or "OHMS" port.
- Dial indicator set to scale above expected indication.

Note: Volts divided by Amps = OHMS

Example: 240V. ÷ 18.75 Amps = 12.8 OHMS

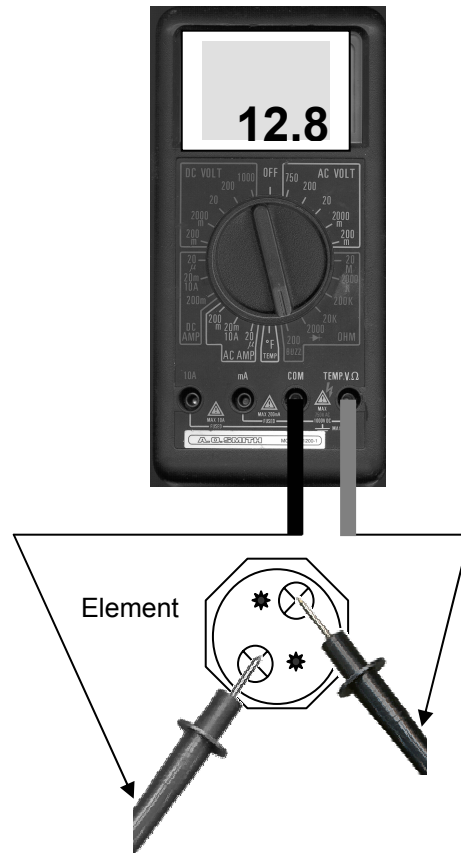

Continuity Check**

Same as above but with meter set to continuity scale. If the meter has an audible indicator, listen for sound..

Test probe on each terminal of an element

Resistance of Element in Ohms (± 7.5%)							
Rated Voltage	Rated Wattage						
	600	750	1000	1250	1500	2000	2500
120	23.2	18.6	13.9	11.1	9.28	6.96	5.57
208	72.1	57.7	43.3	34.6	28.8	21.6	17.3
240	92.8	74.3	55.7	44.6	37.1	27.8	22.3
277	128	102	76.7	61.4	51.2	38.4	30.7
Rated Voltage	Rated Wattage						
	3000	3500	4000	4500	5000	5500	6000
120	4.64						
208	14.4	12.4	10.8	9.61	8.65	7.85*	7.2
240	18.6	15.9	13.9	12.8	11.1	10.1*	9.28
277	25.6	21.9	19.2	17.1	15.3	14.0	12.8
480	76.8	65.7	57.5	51.1	45.7	41.8	38.4

** The above tests can also be conducted with the element removed from the tank.

RESIDENTIAL ELECTRIC WATER HEATER SERVICE HANDBOOK

GROUNDING ELEMENT TEST USING A MULTI-METER

Check Continuity to the Tank

Note: An element's resistance wire is insulated so current cannot reach the outside of the element and come in contact with the water or the tank during normal operation.

1. **Make sure power to the water heater is turned OFF at the circuit breaker or disconnect.**
2. Remove the wires from the element
3. Set the meter to the **Ohms/Continuity** scale. Check the meter by placing the ends of the probes against each other. If the meter has an audible continuity check you should hear a sound when this check is done.
4. Place one probe on an element terminal screw and the other on the tank. Be sure to test both element screw terminals.
5. If the meter has an audible continuity check and you hear the sound on either screw terminal, the element is grounded and must be replaced.

Note: If the meter does not have an audible continuity check, notice the meter reading before the probes are placed together. Depending on the meter the reading should be 1. Perform the above test and if the reading changes, the element is grounded and must be replaced.

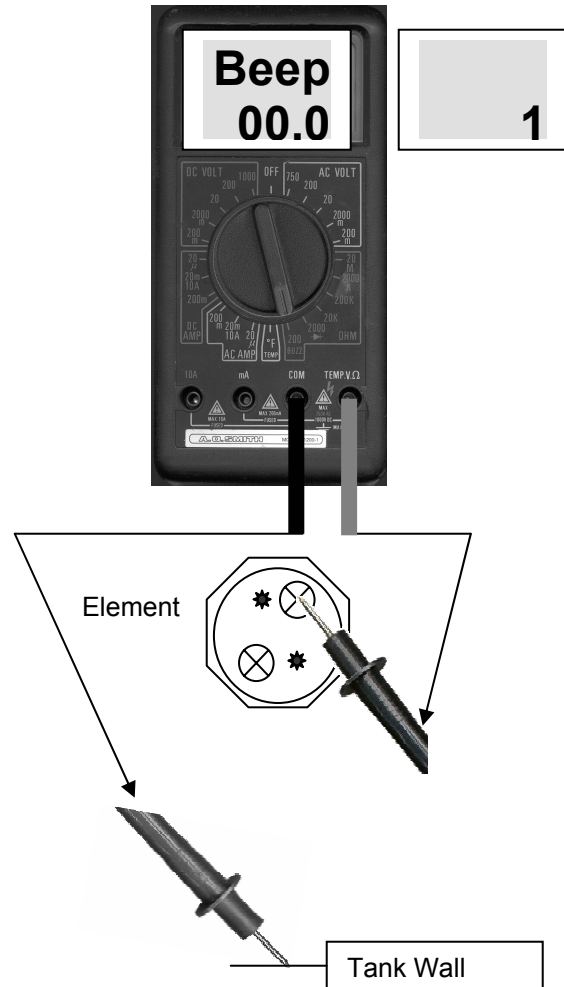

RESIDENTIAL ELECTRIC WATER HEATER SERVICE HANDBOOK

FAILED ELEMENT TEST - AMPERAGE METHOD

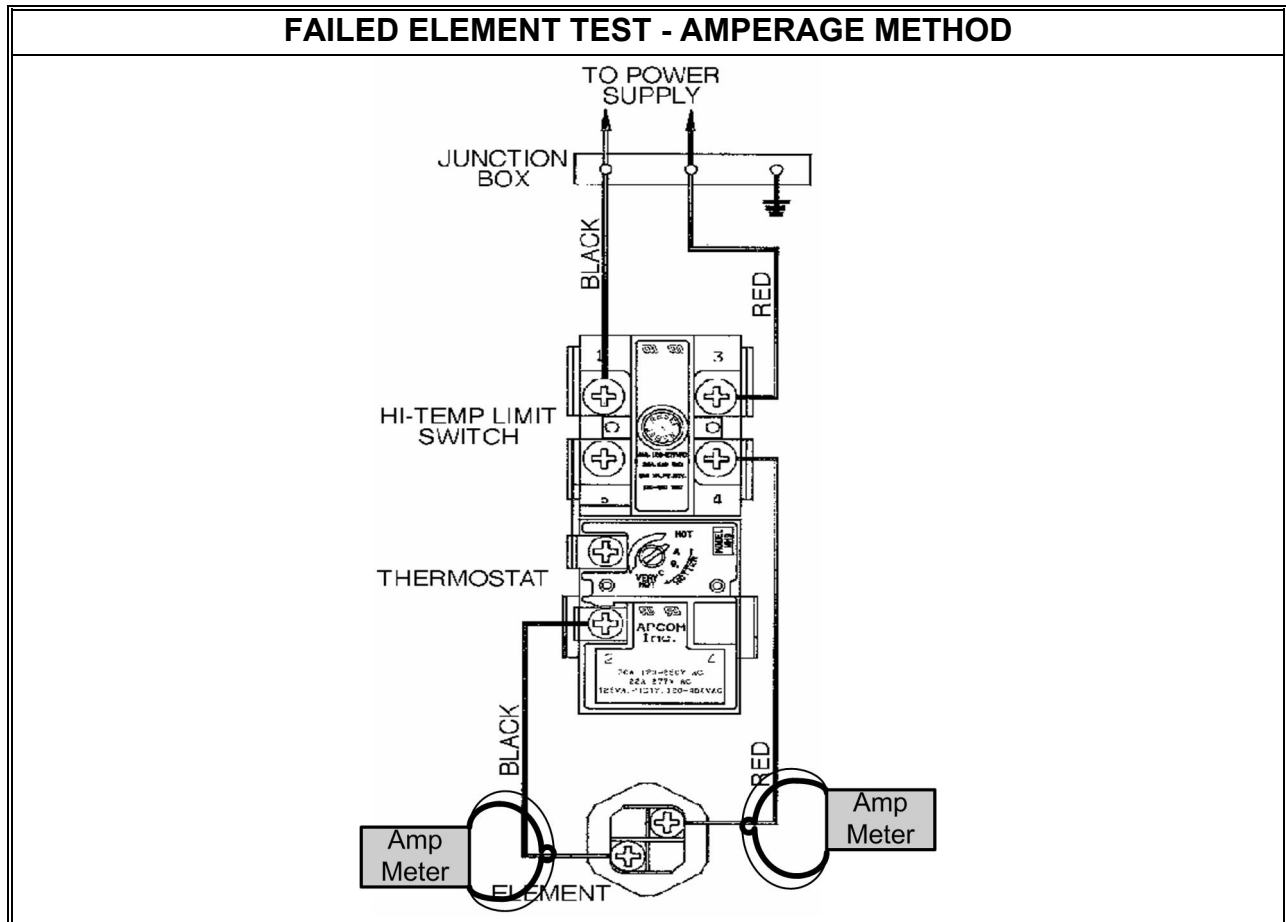

Amperage Check: Measures the flow of current through a wire.

Failed Element Test – using “clamp type” Amperage Meter. Many multi-meters could be used to conduct this test but be certain that possible amperage will not exceed the multi-meter’s limit.

Complaint: No hot water. Check for proper voltage across ECO terminals 2 & 4. If voltage is not detected press the red reset button to activate power and re-check.

Watts divided by volts = Amps **Example:** $4500W / 240V = 18.75 \text{ Amps}$

Conditions: Power on. Thermostat is calling for heat (water in tank is cold).

TEST: CLAMP METER AROUND EACH WIRE TO THE ELEMENT(S). IF THE WATER HEATER HAS TWO ELEMENTS, THE TOP THERMOSTAT MUST BE SATISFIED BEFORE POWER WILL BE SENT TO THE LOWER ELEMENT.

If Amperage is not detected the element must be replaced. (See also: Grounded Element Check with Multi-meter) If partial amperage is noted, the element may be grounded and must be replaced.

RESIDENTIAL ELECTRIC WATER HEATER SERVICE HANDBOOK

GROUNDING ELEMENT CHECK – AMPERAGE METHOD

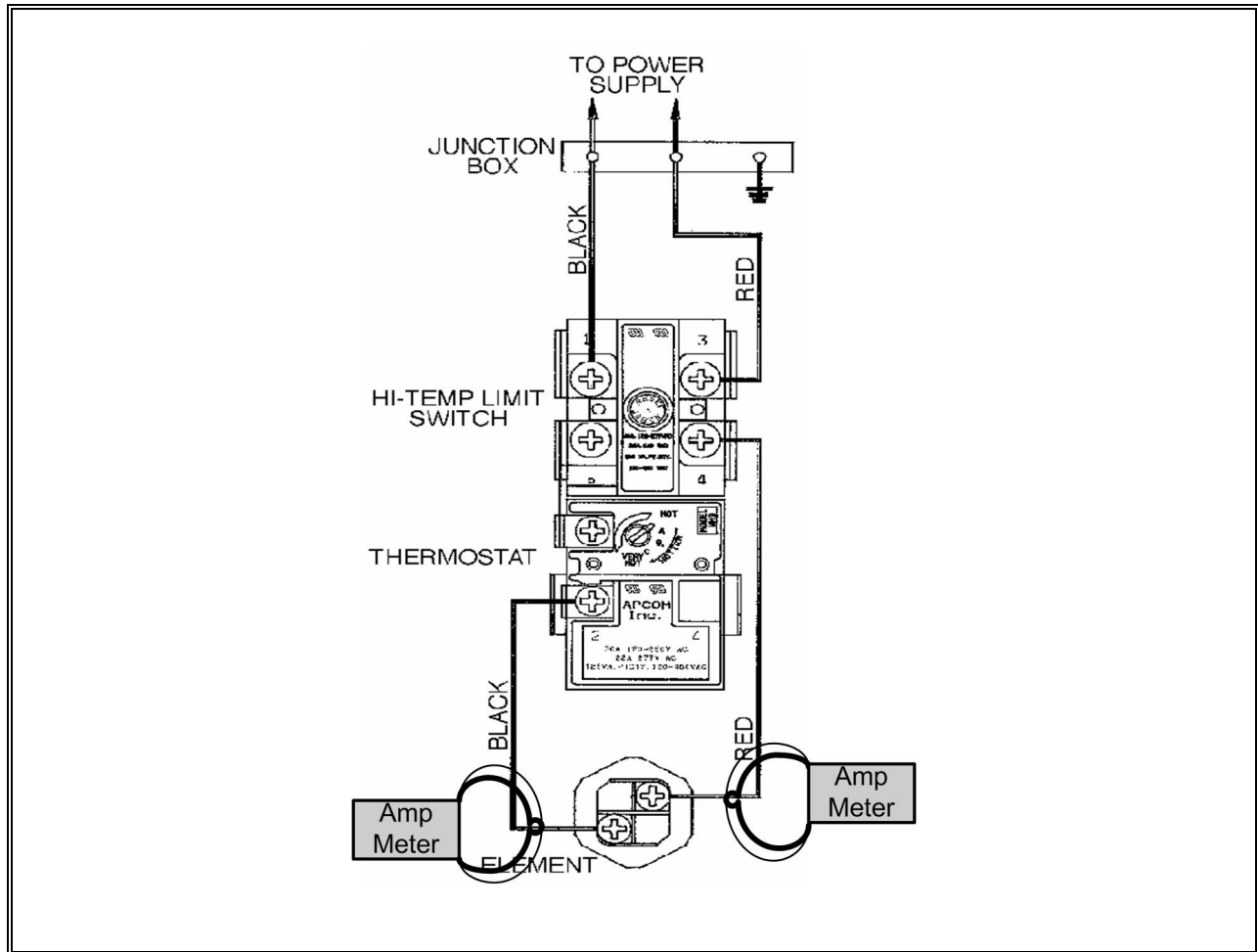

Amperage Check: Measures the flow of current through a wire.

Grounded Element Test – using “clamp type” Amperage Meter. Many multi-meters could be used to conduct this test but be certain that possible amperage will not exceed the multi-meter’s limit.

Complaint: A grounded element is suspected whenever the water temperature becomes **excessively hot** and/or the end user **must push the high limit reset** to reactivate the heater.

Watts divided by volts = Amps

Conditions: Power on. Thermostat is satisfied

TEST: CLAMP METER AROUND EACH WIRE TO THE ELEMENT(S).

IF AMPERAGE IS NOTED THE ELEMENT IS GROUNDED AND MUST BE REPLACED. (See also: Grounded Element Check with Multi-meter)

RESIDENTIAL ELECTRIC WATER HEATER SERVICE HANDBOOK

FIELD WIRING

120 VOLT

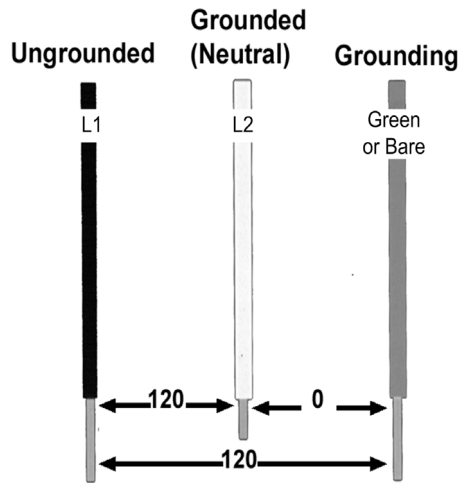

L1 to Ground = 120 Volts
L2 to Ground = 0 Volts

480 VOLT

Three Phase

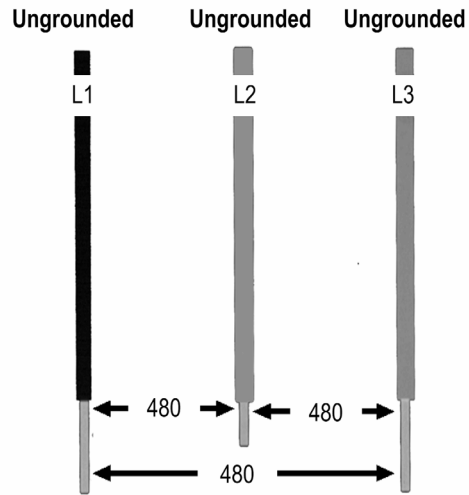

L1 to L2 = 480 Volts
L2 to L3 = 480 Volts
L1 to L3 = 480 Volts
L1, L2, or L3 to Ground = 277 Volts

240 VOLT

Single Phase

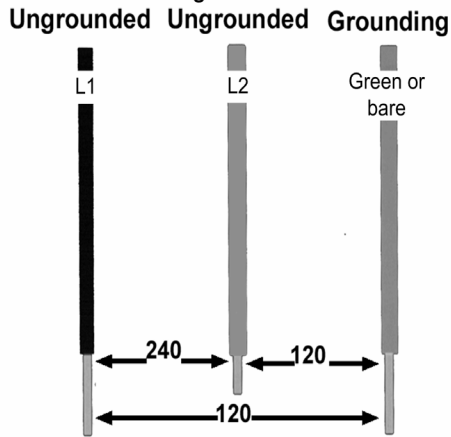

L1 or L2 to Ground = 120 Volts
L1 to L2 = 240 Volts

277 VOLT

Single Phase

Grounded

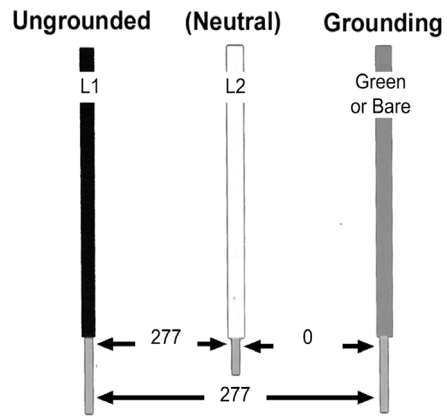

L1 to L2 = 277 Volts
L1 to Ground = 277 Volts
L2 to Ground = 0 Volts

RESIDENTIAL ELECTRIC WATER HEATER SERVICE HANDBOOK

SURFACE MOUNTED THERMOSTAT (S) AND HIGH LIMIT (S)

The thermostats and high limits are held against the side of the tank. As the tank surface heats or cools, a metal disc inside of the control expands or contracts to open or close electrical contacts in the controls. They will satisfy within 10°F of setting. The tank surface has to cool 8 - 15°F to reactivate these controls.

Thermostat models WH9-6 and WH10-7 include a “high limit” or energy cut off (ECO) switch as an integral part of the thermostat. The ECO is attached at the top of the thermostat and has a red reset button in the middle. The ECO will shut off power to the elements if the top of the water heater tank reaches 180° F. temperature. The ECO must be manually reset when the tank cools by pressing the red “reset “button.

Note: If the thermostat is not flat against the tank or the insulation has been removed from the access area, the thermostat may not read the tank temperature properly and may cause the ECO (high limit/reset button) to trip or the T & P valve to open as a result of high water temperature in the tank.

TEMPERATURE ADJUSTMENT

All thermostats on residential electric water heaters are set by the factory at a temperature that approximates 120°F (HOT) and are adjustable. Other temperature indicators are “A” = 130°F., “B” = 140°F., “C” = 150°F and VERY HOT 160°. Read all warnings before proceeding with a temperature adjustment. On dual element models the upper and lower thermostats are adjustable. It is normally not necessary to adjust the upper thermostat. If the upper thermostat is adjusted, it should not be set higher than the lower thermostat. Some models have an external temperature adjustment knob on the lower thermostat and the temperature indicators are the same as the above.



RESIDENTIAL ELECTRIC WATER HEATER SERVICE HANDBOOK

C-2 CIRCUIT WIRING AND SEQUENCE OF OPERATION

C-2 Circuit – Standard on most single element water heaters. Operation from a cold tank of water

- **Single Element**
- **Single Thermostat**
- **Single High Limit**

WH9-6 Thermostat

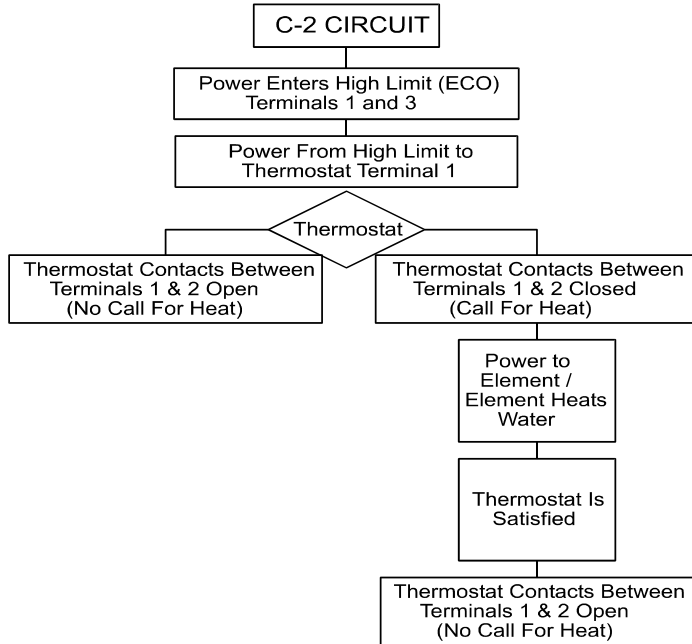
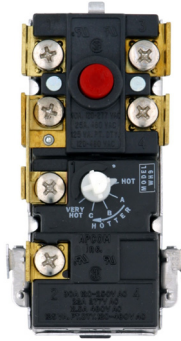

WIRING DIAGRAM

Note: If used on a normally two element heater, controls will be located behind the upper service cover and the element behind the lower service cover.

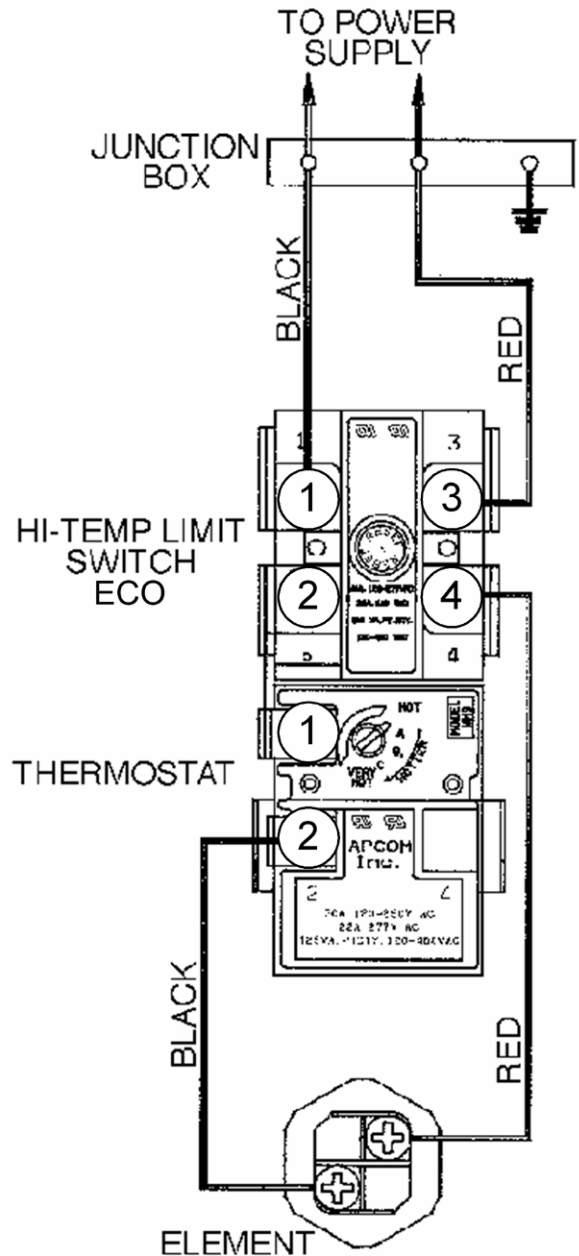

RESIDENTIAL ELECTRIC WATER HEATER SERVICE HANDBOOK

C2 CIRCUIT TESTING SINGLE ELEMENT, SINGLE THERMOSTAT CIRCUIT

COMPLAINT:	POSSIBLE CAUSE	REMEDY
NO HOT WATER	Power off	Check fuse or circuit breaker.
	High Limit (ECO)	Press red (reset) button (p.10)
	Element Burned Out	Continuity Check (p. 8) or amperage check (
WATER TOO HOT	Thermostat set above desired temperature	Adjust thermostat (p.12) Hot setting is about 120°F.
	Element grounded	Check for grounded element See diagram (p.9 & 10)
	Thermostat stuck in call for heat.	Replace thermostat.
WATER NOT HOT ENOUGH	Thermostat set at too low a temperature	See temperature adjustment (p, 12)
REDUCED HOT WATER DELIVERY	Missing or broken dip tube	Check dip tube and replace if necessary
	Sediment accumulation in the tank.	Clean the tank. Drain the tank or use a chemical de-liming agent.

RESIDENTIAL ELECTRIC WATER HEATER SERVICE HANDBOOK

A - 6 CIRCUIT (INTERLOCK OR NON-SIMULTANEOUS)

COMPONENTS

A-6 Circuit

- 2 Elements
- 2 Thermostats
- 1 High Limit

A-6 Circuit - Standard on dual element water heaters non-simultaneous / interlocked operation.

UPPER THERMOSTAT WH10-7



LOWER THERMOSTAT WH9-2



WIRING DIAGRAM

A-6 WIRING CIRCUIT

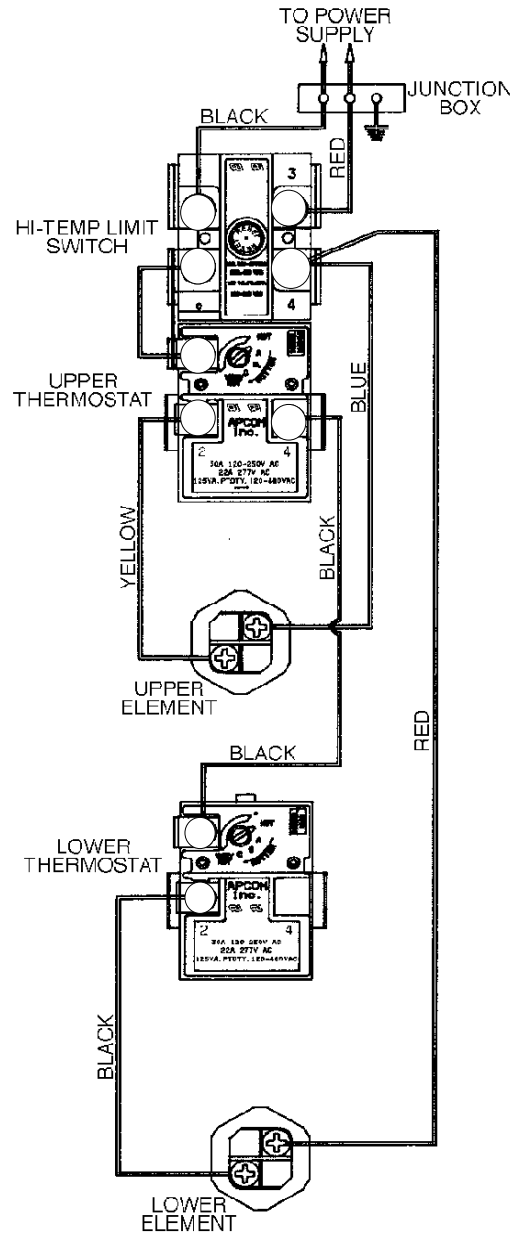

RESIDENTIAL ELECTRIC WATER HEATER SERVICE HANDBOOK

SEQUENCE OF OPERATION:A-6 CIRCUIT COLD TANK STARTUP

Note: The operation sequence at right only applies to the initial cold tank start. On successive cycles cold water entering the tank is forced to the bottom by the dip tube. The lower element is usually energized first on successive hot water draws as cold water enters the tank.

In most water heater applications the lower element and the lower thermostat do over 90% of the water heating job.

The upper element is only energized again when the entire tank is cold and the upper thermostat calls for heat.

If the upper element burns out, the upper thermostat call for heat will never be satisfied and power will not be transferred to the bottom thermostat and element.

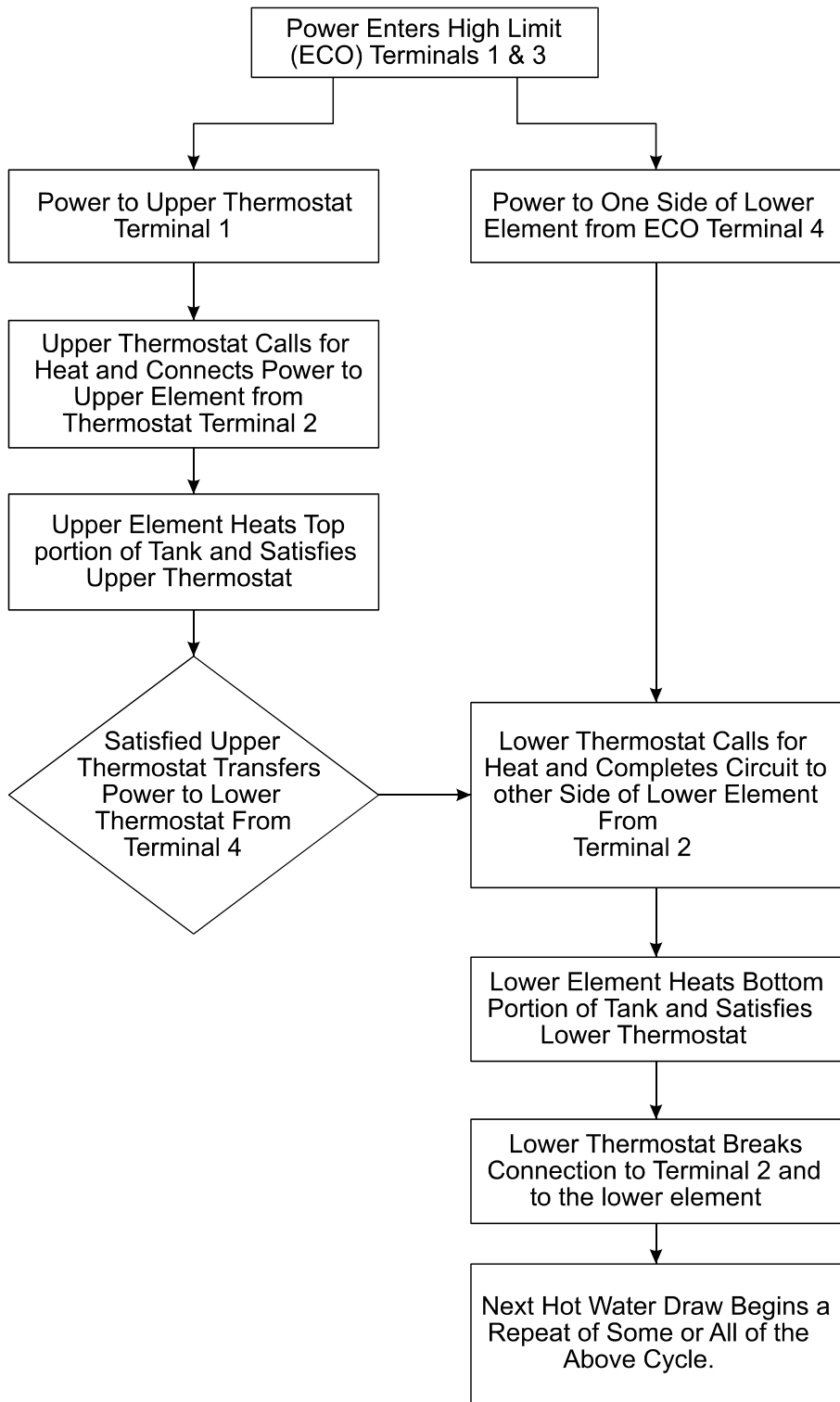

RESIDENTIAL ELECTRIC WATER HEATER SERVICE HANDBOOK

A-9 OFF PEAK/TIME CLOCK CIRCUIT

- 2 Elements
- 2 Thermostats
- 2 High Limits
- 3 Wire

Three wire circuit for non-simultaneous element operation and single-phase power. This circuit permits off-peak meter usage or connection to a 3-phase supply circuit.

**UPPER THERMOSTAT
WH10-7**

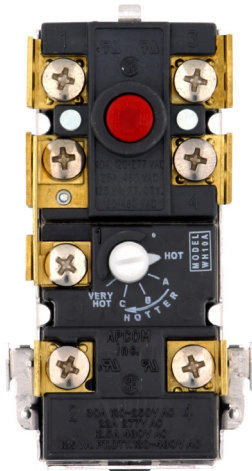

**LOWER THERMOSTAT
WH9-6**

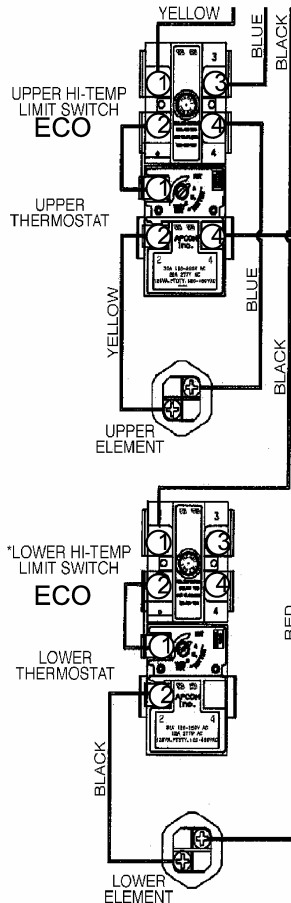
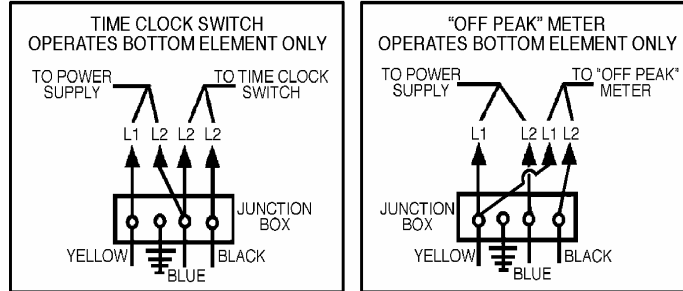

RESIDENTIAL ELECTRIC WATER HEATER SERVICE HANDBOOK

SEQUENCE OF OPERATION: OFF-PEAK/TIME CLOCK CIRCUIT COLD TANK START

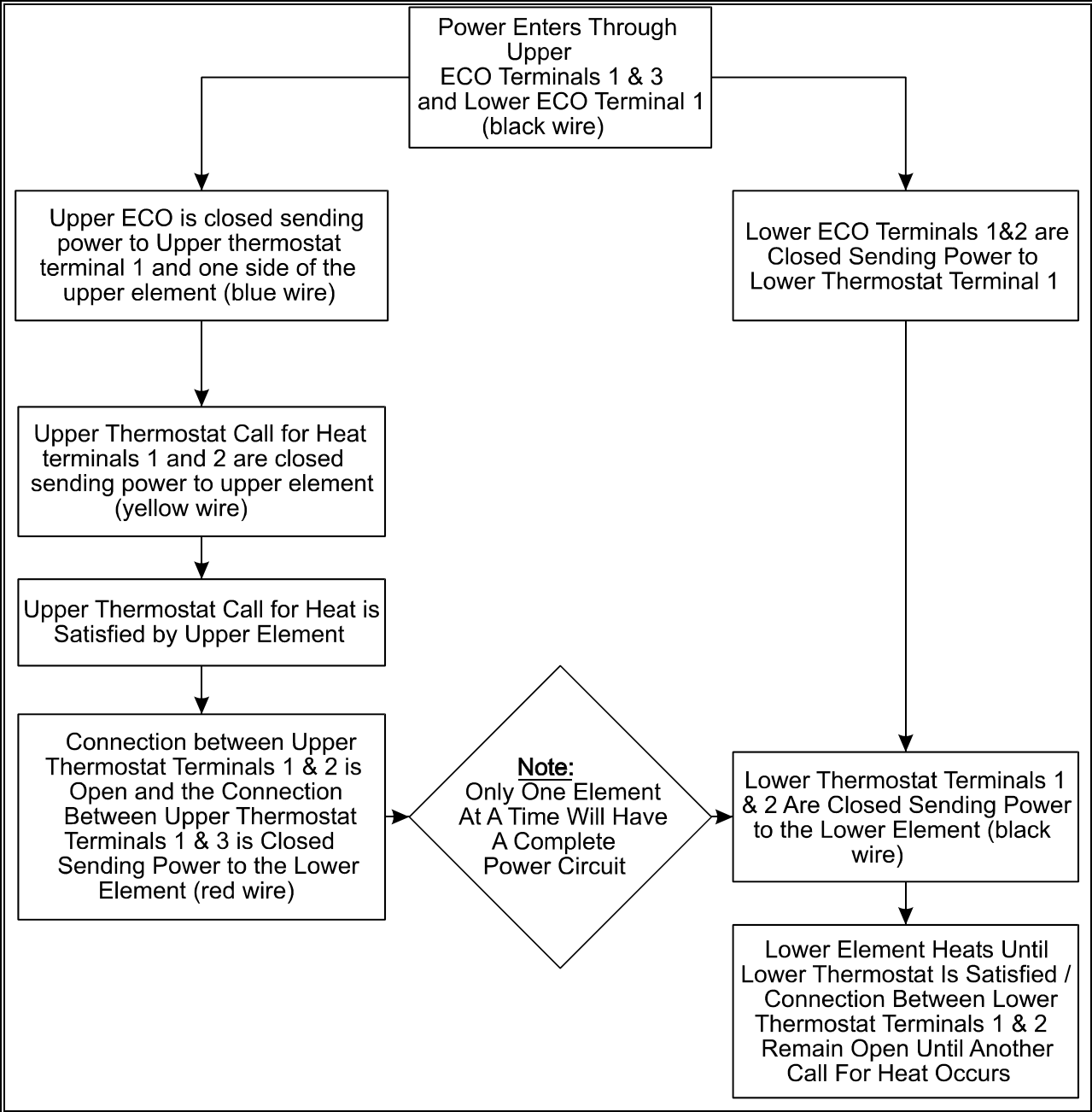

Cold tank of water

- Single Electrical Service
- Single Phase

RESIDENTIAL ELECTRIC WATER HEATER SERVICE HANDBOOK

THREE-PHASE UN-BALANCED CIRCUIT

Note: For simplicity, the thermostats are not shown.

UNBALANCED 3 PHASE LOAD

Three phase power delivers power with 3 legs to the water heater. The water heater must be specially wired to accept three phase power. Since there are only two elements with two wire terminals each in the water heater, power from a three leg power supply cannot be divided evenly. One leg will have a higher amperage draw than the other two.

In the diagram at right the connection to power leg L2 will have the higher amperage draw. The chart below gives the amperage draw for L1, L2, and L3. The maximum amperage draw per leg is never allowed to exceed 48 Amps in accordance with the National Electric Code. **The chart only applies when elements are wired for simultaneous operation.**

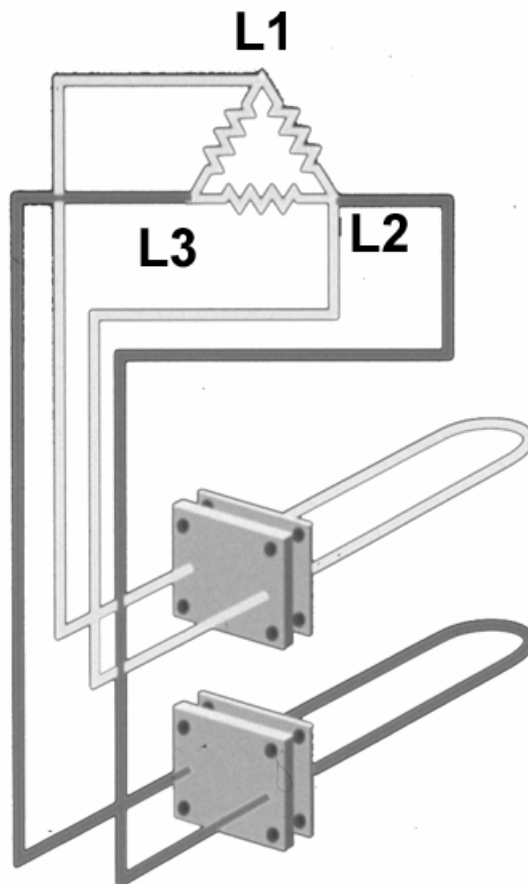

SIMULTANEOUS DUAL ELEMENTS (both elements 'on' when entire tank is cold)			
Element Wattage Upper/Lower	Full Load Current in Amperes Connected to Three Phase Power (Terminal L2/ Terminals L1 & L3)		
	208V	240V	480V
3000/3000	25.0/14.4	21.7/12.5	10.8/6.3
4000/4000	33.3/19.2	28.9/16.7	14.4/8.3
4500/4500	37.5/21.6	32.5/18.8	16.2/9.4
5000/5000	N/A	36.1/20.8	18.0/10.4
6000/6000	N/A	N/A	21.7/12.5

Formula: L2 Amps = wattage* x 1.73 / volts
***Wattage = 1/2 of total wattage.**

RESIDENTIAL ELECTRIC WATER HEATER SERVICE HANDBOOK

TESTING THE A-9 OFF-PEAK / TIME CLOCK CIRCUIT OPTIONAL UNBALANCED 3-PHASE CIRCUIT

A-9 Circuit:

Two elements
Two thermostats
Two high limits
3 wires

Note: The standard **A-9** circuit is designed as an **interlock** circuit – only one element at a time can receive power.

If the water heater has been wired for simultaneous operation, the red wire on upper thermostat terminal 4 in the diagram will be moved to upper ECO terminal 4.

Warning:

Attempting an unauthorized field conversion will double the amperage draw and may overload the wiring to the water heater resulting in a fire hazard.

Warning

Maximum amperage draw if wired for simultaneous operation is 48amps in accordance with the National Electrical Code. Internal wiring may further reduce maximum amp draw.

The **A-9** circuit may also be used for **three phase power**. Three phase power is typically used in commercial applications. Using a residential water heater in a commercial application will result in a reduction of the tank warranty and the parts warranty.

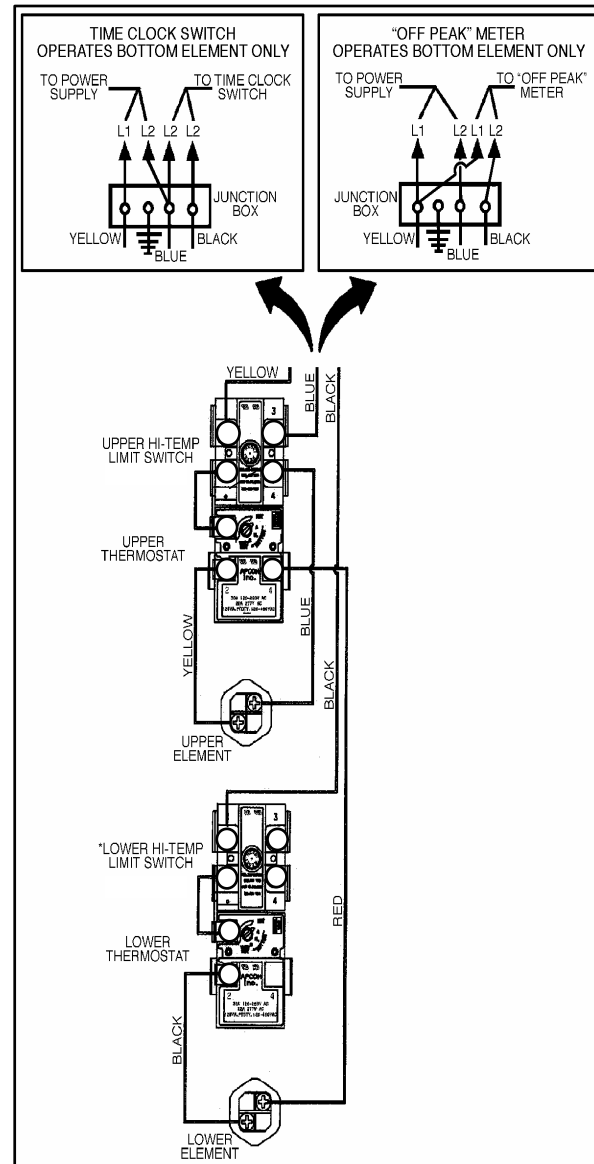

RESIDENTIAL ELECTRIC WATER HEATER SERVICE HANDBOOK

TESTING THE A-9 OFF-PEAK / TIME CLOCK CIRCUIT

Connection to an off-peak clock interrupts power to the lower thermostat and heating element during the designated time period but does not interrupt power to the upper thermostat. If the consumer uses enough of the stored hot water to drop tank temperature at the top of the tank to call for upper element activation, then the upper element will reheat the upper third of the tank. This installation typically requires a larger volume tank to give the homeowner as much hot water as possible while the clock has the power interrupted.

VOLTAGE CHECKS

These tests are conducted on the water heater, below the junction box.

Complaint: No Hot Water
Test Conditions: Tank is full of cold water (or at least 15°F below the upper thermostat setting).
Power on: Upper thermostat calling for heat
 Multi-meter set to the proper AC voltage scale.

Test between upper high limit terminals 1 and 3

If then
the proper voltage is not present (disconnect)	Check the power from the breaker or fused disconnect.
the proper voltage is present	Check the wiring in the water heater junction box and continue to the next step.

Test between upper high limit terminals 2 and 4

If then
the proper voltage is not present	Push the red reset button – if this establishes proper voltage, conduct the thermostat and element checks before changing the high limit.
pushing the reset does not restore voltage	Replace the high limit.
the proper voltage is present	Continue to the next step.

Test between upper high limit 4 and upper thermostat 2

If then
the proper voltage is not present high limit 4 and upper thermostat 2	Replace the upper thermostat
the proper voltage is present	Conduct upper element checks. The top 1/3 of the tank should be hot.

RESIDENTIAL ELECTRIC WATER HEATER SERVICE HANDBOOK

TESTING THE A-9 OFF-PEAK / TIME CLOCK CIRCUIT
--

Complaint: Lack of Hot Water

Test Condition: Upper thermostat satisfied

Test between upper high limit 4 and upper thermostat 4

If then
proper voltage is not present	Replace upper thermostat.
proper voltage is present	Continue to next step.

Test between lower high limit 2 and upper thermostat 4

If then
proper voltage is not present	Push lower high limit reset. Check time clock or off peak meter.
pushing reset restored voltage	Conduct lower element checks
pushing reset did not restore voltage	Replace lower high limit
proper voltage is present	

Test between the terminals of the lower element

If then
proper voltage is not present:	Check wire connections to lower controls.
proper voltage is present:	Conduct grounded element checks.

RESIDENTIAL ELECTRIC WATER HEATER SERVICE HANDBOOK

Miscellaneous Residential Electric Water Heater Service Items:

- **Watts divided by Volts = Amps**
Supply wire gauge and fuse (breaker) protection must be at least 125% of the expected Amperage draw of the water heater.
- **Volts times Amps = Watts**
Replace elements with elements rated at the same wattage and voltage indicated on the water heater model and rating plate. Installing an element with a **higher** voltage rating or wattage output may create a safety hazard by overloading the water heater wiring or supply wiring or fusing. Installing an element with a **lower** wattage or voltage rating will reduce performance.
- Normally, a residential electric water heater with two elements will have **only one** element operate at a time. If the upper element or thermostat fails, the customer will be out of hot water. If the lower element or thermostat fails, the customer **should still** have 1/3 of the tank with hot water.
- With a two element water heater, the **lower element and thermostat** will **cycle more** frequently than the upper element and thermostat. For this reason, the lower element will normally accumulate lime faster and fail more often than the upper element. Lower thermostats will fail more often than upper thermostats.

RESIDENTIAL ELECTRIC WATER HEATER SERVICE HANDBOOK

SERVICE BULLETINS

The following are bulletins designed to help service the standard, residential gas and electric model water heaters. These bulletins and more are available on the website www.statewaterheaters.com.

This information is intended to supplement service and maintenance information found in the heater installation and operation manual.

“Why water heaters leak” information 26

Index of Technical Bulletins:

Water Hammer	27
Mineral Buildup	28
Aluminum Hydroxide	29
Discolored Water.....	30
Smelly Water.....	31
Chlorination Procedure.....	32
Not Enough Hot Water – Electric	33
Thermal Expansion	34
Leaking Temperature and Pressure Relief Valve.....	36

RESIDENTIAL ELECTRIC WATER HEATER SERVICE HANDBOOK

WHY WATER HEATER TANKS LEAK		
WHAT	WHY	PREVENTION
Water Pressure	Water expands when it is heated (Thermal Expansion). Water cannot be compressed. Excessive Pressure in the tank causes failure of joints, welds or gaskets.	A Temperature and Pressure Relief Valve limits pressure to a maximum. Adding a Thermal Expansion Tank limits pressure to near supply water pressure.
Soft Water	Soft water minimizes mineral buildup within the tank. Minimal minerals maintain the water heater at high efficiency but may also expose interior surfaces to corrosion. Mineral buildup in some heaters prevents them leaking while greatly reducing efficiency.	A metal "Anode" rod within the tank helps to prevent internal corrosion. Maintain the self sacrificing "anode" rod by inspecting the rod annually and replacing when large "gouges" appear in its surface.

WATER CONDITIONS		
WHAT	WHY	PREVENTION
"Hard" Water (Electric Water Heaters)	See above explanation. Lime (calcium) forms on the electric elements. Elements become excessively hot and may split. Split elements often leak to the outside of the heater.	Inspect and clean elements as necessary. Add a water softener. Install elements resistant to failure due to Lime (mineral) build up.
Water Temperature	Water stored at 160°F (72 °C) may be twice as corrosive as water stored at 140°F (60°C)	Begin with a water heater setting of 120°F (49°C) and increase only as necessary.
Usage	Each time the burner or elements cycle on and off, a small amount of metal expansion and contraction take place. As bending a piece of wire back and forth will break the wire, this expansion and contraction will eventually crack tank joints or welds.	Purchasing a proper sized tank will minimize burner or element operation when only small quantities of hot water are used.

For more detailed explanation on this information as well as additional service information, see the State Industries Web site www.statewaterheaters.com under "Technical Information". 0801 form TC-063

RESIDENTIAL ELECTRIC WATER HEATER SERVICE HANDBOOK

TECHNICAL BULLETIN BULLETIN 11

WATER HAMMER

GENERAL	<p>Water hammer is the destructive forces, pounding noises and vibration in a piping system when water flowing through a pipeline is stopped abruptly. When water hammer occurs, a high intensity pressure wave travels back through the piping system until it reaches a point of some relief. The shock wave will then surge back and forth between the point of relief and the point of stoppage until the destructive energy is dissipated in the piping system. The violent action accounts for “banging”, “thumping”, and/or intense vibration in the pipe line. Although noise is generally associated with the occurrence of water hammer, it can occur without audible sound or noise. Quick closure always causes some degree of shock with or without noise. The common cause of water hammer is single lever faucets (sinks/lavatories) or automatic solenoid valves (dishwashers, washing machines, etc.). The speed of the valve closure time is directly related to the intensity of the surge pressure.</p>
EFFECTS	<p>The damage from water hammer can manifest itself in a number of ways. The most common are:</p> <ul style="list-style-type: none">• <i>Expanded Tank Shell</i> - This can be demonstrated by measuring the circumference at various locations along the shell. Pressures in excess of the maximum design working pressure can cause permanent deformation of the shell.• <i>Collapsed Flue Tube</i> - This will choke off the ability to vent the products of combustion causing the flame and/or combustion to spill out from the combustion chamber. Often this will occur where thinning of the flue tube walls has occurred due to contamination of the combustion air or because of excessive condensation.• <i>Inverted or Deformed Tank Heads</i> - Often this accompanies collapsed flues, but one or both heads can be deformed.
THE FIX	<p>The only effective means of control is to install water hammer arrestors. These devices have diaphragms, which separate an air chamber from the water in the piping system. As the shock wave reaches this device, the air chamber absorbs the shock. Arrestors should be located as close as possible to the source of the shock wave.</p>
NOTES	<p>Since water hammer exposes the equipment to pressures in excess of its design limits, failures caused by water hammer are not eligible for warranty consideration.</p>

RESIDENTIAL ELECTRIC WATER HEATER SERVICE HANDBOOK

TECHNICAL BULLETIN

BULLETIN 13

MINERAL BUILD-UP

SYMPTOMS	<ul style="list-style-type: none">• Rumbling	<ul style="list-style-type: none">• Crackling	<ul style="list-style-type: none">• Popping
-----------------	--	---	---

CAUSE	<p>With the advent of high input and larger storage tanks in both commercial and residential heaters, deliming has become a necessity of modern maintenance. Lime (CaCO_3), is the most notable factor when discussing water hardness. Lime is present in every water system to some degree across the entire United States. Since lime is inversely soluble [the more you heat, the more lime comes out], higher usage, excessive hardness, and increased heating surface can lead to a high incidence of "limed-up" heaters.</p> <p>Symptoms often include a popping of water trapped under lime deposits or the sizzling of water trapped next to elements, boiling it to steam.</p>
--------------	---

THE FIX	<p>Treatment of a "limed-up" water heater is relatively simple. Since CaCO_3 is a base, the easiest way to dissolve it so it can be flushed from the heater is with an acid. The most commonly used is phosphoric acid at a food-grade level.</p> <p>Two common treatments marketed by the manufacturer are Mag-Erad® and Un-Lime®. Any well-stocked plumbing supply house should have a deliming solution available.</p> <p>The directions on the product should be followed explicitly.</p>
----------------	---

NOTES	<p>For additional information and instructions in deliming water heaters and boilers, please refer to the following pamphlets available from A.O. Smith:</p> <ul style="list-style-type: none">• <i>Why? When & How: To Remove Water Scale from Tank Type Water Heaters</i>• <i>The Mag-Erad® Method of Cleaning Gas Fired Water Heaters</i>• <i>Up-N-Down™ Transfer Kit</i>• <i>All About Deliming Coil Type Water Heaters</i>
--------------	--

RESIDENTIAL ELECTRIC WATER HEATER SERVICE HANDBOOK

TECHNICAL BULLETIN

BULLETIN 14

ALUMINUM HYDROXIDE

SYMPTOMS	“Crackling”, “gurgling”, or “popping” noises from new water heaters (installed less than six months).
-----------------	---

CAUSE	In a few isolated parts of the United States where the water supply has a relatively high pH (8+), water conditions will react with the aluminum anode to form excessive amounts of aluminum hydroxide on the anode and in the bottom of the tank. Aluminum hydroxide looks like “jelly beads” or a green, blue or gray gel like substance in the heater drain or at faucet aerators.
--------------	---

THE FIX	This procedure should only be performed by someone with abilities equal to a licensed tradesman. Aluminum hydroxide can be removed by using one of the methods outlined.
----------------	--

	If tank is new <u>with no</u> lime build-up to any degree:
1	Turn off the heater.
2	Remove the anode.
3	Flush the tank thoroughly with water.
4	Replace the aluminum anode (<i>identifiable by smooth surface on plug</i>) with magnesium anode (<i>identifiable by weld bead on plug</i>).
	If the tank is new <u>with</u> lime build-up to any degree:
1	Turn off the heater.
2	Drain the heater.
3	Remove the anode.
4	Add UN-LIME to the tank. 20-40 gallon models (use 3 gallons of UN-LIME) 41-65 gallon models (use 5 gallons of UN-LIME) 66-100 gallon models (use 7 gallons of UN-LIME) <i>(On electric models, be certain the lower element is immersed in solution.)</i>
5	Heat the UN-LIME to a temperature of 140°F to 160°F. <ul style="list-style-type: none"> • GAS - Heat for 7 to 10 minutes. • ELECTRIC - Power off and remove the yellow wire from terminal 2 on the upper thermostat. Move the red wire from terminal 4 of the upper thermostat to terminal 2 of the upper thermostat. This allows operation of the lower element only. Restore power to the heater. Be certain that only the lower element is operating. Heat for 7 to 10 minutes.
6	Shut off the water heater.
7	Allow the heated UN-LIME to stand for up to 12 minutes.
8	Drain and flush the tank. Caution: UN-LIME will still be hot.
9	Replace the original aluminum anode with a magnesium anode.
10	Fill the system with water.
11	On electric models, return the wiring to its original configuration.
12	Turn heater fuel “ON”.

NOTE	Since aluminum hydroxide is a product of a chemical reaction dependent on the water condition, any treatment is not considered warranty related.
-------------	--

RESIDENTIAL ELECTRIC WATER HEATER SERVICE HANDBOOK

TECHNICAL BULLETIN

BULLETIN 21

DISCOLORED WATER

SYMPTOMS	Rusty, brown, black, or yellow water appearing in the hot water.
CAUSE	<p>Complaints of discolored water are commonly blamed on water heaters and storage tanks, but in fact, it is a rare occurrence for today's high quality glass lined tanks to have a lining failure significant enough to allow water to contact enough bare metal to discolor the contents of even a small tank.</p> <p>The most common cause of "rusty" water is a non-toxic iron reducing bacteria, scientifically termed Crenothrix, Leptothrix, and Gallionella. Iron bacteria is commonly found in soil, water wells, water treatment plants and water distribution piping systems where soluble iron exceeds 0.2 ppm, higher levels make conditions even more favorable. Soluble iron in the water provides food for the bacteria. Rusty discolored water is the end result of the bacteria feeding process. Water heaters and storage tanks usually require new anode rods as presence of iron bacteria contributes to premature anode failure.</p> <p>The requirements for the bacteria to thrive are:</p> <ul style="list-style-type: none"> • Elevated level of iron and manganese in the water • Water with little or no dissolved oxygen • Temperatures below 138°F <p>Items that can increase the potential for this bacteria are:</p> <ul style="list-style-type: none"> • Water softeners • Well water • Long periods of no water movement
TREATMENT	The simplest treatment available is shock-chlorination of the system. This is a surface treatment, and often requires repeated trials in heavily infected systems. The chlorination of a system requires that you follow each step explicitly to avoid an un-treated portion of the piping system from reinfesting another part. See Bulletin 23 for the chlorination procedure.
NOTE	Since rusty water is caused by a bacteria presence and is not caused by the water heater, any treatment would not be considered warranty related.

RESIDENTIAL ELECTRIC WATER HEATER SERVICE HANDBOOK

TECHNICAL BULLETIN

BULLETIN 22

SMELLY WATER

CAUSE	<p>The most common cause of “smelly water” is a non-toxic sulfate reducing bacteria, scientifically termed <i>Divibrio Sulfurcans</i>. This bacteria often enters the water system through construction or a break in ground piping. The bacteria create the energy it needs to survive by converting sulfate (SO₄) to hydrogen sulfide (H₂S) gas you smell in the water.</p> <p>Hydrogen sulfide gas is distinctive because of its rotten egg-like stench. Its presence can severely affect the taste as well as the odor of the water. Occasionally this bacteria can be accompanied by black deposits, the result of pipe and fitting corrosion. In extremely high concentrations, hydrogen sulfide gas can be toxic though the gas is detectable long before harmful levels are reached.</p> <p>The requirements for the bacteria to thrive are: a) an elevated level of sulfur in the water, b) activated hydrogen from cathodic reactions within the tank, c) water with little or no dissolved oxygen, d) and temperatures below 138°F.</p> <p>Items that can increase the potential for this bacteria are: a) water softeners, b) well water, c) and long periods of no water movement.</p> <p>Other factors that may contribute to smelly water:</p> <ul style="list-style-type: none"> • Chlorides of Magnesium and Calcium leave a bitter taste. • Chloride of Sodium produces a salty taste. • Sulfates (50 ppm) give a medicinal taste. • Carbon Dioxide in a low pH water gives fizzy water. • Iron and tannic waters also give a bad taste and odor.
TREATMENT	<p>The simplest treatment available is the shock-chlorination of the system. This is a surface treatment, and often requires repeated trials in heavily infected systems. The chlorination of a system requires that you follow each step explicitly to avoid an untreated portion of the piping system from reinfesting another part. See Bulletin 23 for the chlorination procedure. Longer lasting solutions include chlorination or aeration of the water supply.</p>
NOTE	<p>Since smelly water is caused by a bacteria presence and is not caused by the water heater, any treatment would not be considered warranty related.</p>

CAUSE	<p>The chlorination procedure is used to eliminate various bacteria that accumulate and grow in water heaters. These bacteria often cause odorous or discolored water conditions.</p>
--------------	---

RESIDENTIAL ELECTRIC WATER HEATER SERVICE HANDBOOK

TECHNICAL BULLETIN

BULLETIN 23

CHLORINATION PROCEDURE

PROCEDURE	
	Please read the steps of the chlorination procedure prior to beginning. If you feel uncomfortable performing any of these steps, contact a service person to perform this procedure for you.
STEP 1	Turn off the gas or electric supply to the tank.
STEP 2	Turn off the cold water supply valve to the tank.
STEP 3	Open a nearby hot water faucet to relieve the vacuum.
STEP 4	Drain all the water from the tank (a water-hose may be needed).
STEP 5	Remove the anode rod(s), and close the drain valve.
STEP 6	Using a funnel in the anode opening add one gallon of household chlorine bleach (e.g. Clorox or Purex) for every 25 gallons of tank capacity.
STEP 7	Reinstall anode rod(s) after inspecting and replacing as needed.
STEP 8	Open cold water supply valve and refill the system. Then draw the water to every hot water fixture, until the smell of chlorine is detected. Operate dish and clothes washers until a noticeable amount of the chlorine is detected as well. All hot water lines must receive treatment.
STEP 9	Leave the chlorine solution undisturbed for one hour or more.
STEP 10	After the contact time has elapsed, drain the tank according to steps #2, #3, & #4.
STEP 11	Close the drain valve and refill the tank. Allow the tank to sit for 15 minutes. Repeat steps #2, #3, and #4. Continue to flush the tank if the water is discolored or contains a chlorine odor.
STEP 12	Close the drain valve and refill the tank. Flush <u>all</u> chlorine from the piping by opening every hot water outlet/ appliance.
STEP 13	Return hot water heating system to service by following the recommended start-up procedure posted on the unit or in the manual.

RESIDENTIAL ELECTRIC WATER HEATER SERVICE HANDBOOK

TECHNICAL BULLETIN

BULLETIN 36

NOT ENOUGH HOT WATER - ELECTRIC

CAUSE	Not enough hot water complaints are becoming more frequent in the water heater industry. This increase was triggered when changes required by our regulatory agencies were implemented. For example, heaters are now factory preset at a lower temperature and inlet tubes have been shortened. While lower temperatures settings reduce the burn rate, and shorter dip tubes guard against stacking, both affect the amount of hot water a water heater can supply. The following test will help determine if a water heater is supplying the intended amount of hot water and will help pinpoint any problems that exist.														
TEST	Please read all the steps of the test prior to beginning. If you feel uncomfortable performing any of these steps, contact a service person to conduct this test for you.														
STEP 1	At the faucet nearest to the water heater, time (in seconds) how long it takes to fill a 1 gallon bucket (flow rate). Gallon per minute (gpm) = 60 seconds / seconds to fill a 1 gallon bucket If the bucket fills in: 10 sec = 6 gpm 12 sec = 5 gpm 15 sec = 4 gpm 20 sec = 3 gpm 24 sec = 2.5 gpm														
STEP 2	Turn both upper and lower thermostat dials on the water heater to 130° F.														
STEP 3	Run about 15 gallons of hot water from the nearest faucet. Shut water off.														
STEP 4	Water heater should complete heating 15 gallons in approximately 45 minutes														
STEP 5	At a nearby faucet using a candy thermometer, measure the hot water temperature.														
STEP 6	The temperature should fall between 120°F to 140°F.														
STEP 7	Continue running the hot water until 60% of the tank capacity is depleted: <table style="margin-left: auto; margin-right: auto; border: none;"> <thead> <tr> <th style="text-align: left;">CAPACITY</th> <th style="text-align: left;">DEplete</th> </tr> </thead> <tbody> <tr> <td>30 gallons</td> <td>18 gallons</td> </tr> <tr> <td>40 gallons</td> <td>24 gallons</td> </tr> <tr> <td>50 gallons</td> <td>30 gallons</td> </tr> <tr> <td>66 gallons</td> <td>39 gallons</td> </tr> <tr> <td>80 gallons</td> <td>48 gallons</td> </tr> <tr> <td>120 gallons</td> <td>72 gallons</td> </tr> </tbody> </table>	CAPACITY	DEplete	30 gallons	18 gallons	40 gallons	24 gallons	50 gallons	30 gallons	66 gallons	39 gallons	80 gallons	48 gallons	120 gallons	72 gallons
CAPACITY	DEplete														
30 gallons	18 gallons														
40 gallons	24 gallons														
50 gallons	30 gallons														
66 gallons	39 gallons														
80 gallons	48 gallons														
120 gallons	72 gallons														
STEP 8	At the same faucet using a candy thermometer, measure the water temperature.														
STEP 9	The temperature should be about 30°F below the temperature in step 6.														
THE FIX	Step 6 - if the temperature was not within range, check the thermostats. Step 9 - if more than 30 °F was lost; check the lower element for continuity and the dip tube.														

RESIDENTIAL ELECTRIC WATER HEATER SERVICE HANDBOOK

TECHNICAL BULLETIN

BULLETIN 45

THERMAL EXPANSION

SYMPTOMS	<ul style="list-style-type: none"> • Effects are only noticeable after hot water use followed by periods of no water use. • Relief valve drips during any recovery cycle when no hot or cold water is used. • Hot water pipes creak while heater is recovering and all valves are closed. • Tanks or other components of the water supply system fail prematurely. • A metallic creaking noise might actually be heard in the location of the heater as the pressure is relieved and the stretched tank returns to a natural shape. • Faucets drips during any recovery cycle when no hot or cold water is used. <p>Water surges when a valve is first open and then pressure drops.</p>
CAUSE	<p>The water in a water heating system expands when it is heated and has a greater volume. Since water will not compress (like air), system designers must include provisions for thermal expansion. (Water in a closed tank at 50 psi, when heated just 10 degrees, will reach a pressure of 250 psi).</p> <p>Many water supply systems have check valves at the water meter to prevent any possible contamination of the public water supply by the accidental back-flow of contaminated water into the supply mains. These check valves are often required by code, and some cities are even installing the check valves. They serve a useful purpose. Do not remove them!</p> <p>The use of pressure reducing valves (PRV) is another cause. PRVs are designed to conserve water and prolong fixture life. Many PRVs also act as very effective check valves. Again, do not remove them!</p> <p>Water softeners in the system may also act as a back-flow prevention device.</p>
TEST	<p>Follow these easy steps to diagnose thermal expansion:</p> <ul style="list-style-type: none"> • Turn the heater thermostat all the way down, and install a water pressure gauge with dead hand (AOS part #4798) on the drain valve. Open the drain valve, so the gauge reads system pressure. • Open a hot water tap and allow 15% to 20% of the tanks volume to run out. Shut off the drain valve and make sure that no other fixture in the system, hot or cold, is open. Make sure that outside fixtures, if they are on the same system, are turned off too. Any water leaks or use will make the test meaningless. • Check the water pressure gauge, and turn the pointer so it lines up with the pressure indicating needle. Turn the thermostat back up to its normal position, so the heater cycles on. Watch the pressure gauge. • If the system is closed, the pressure will start to climb steadily and rapidly. A small amount of thermal expansion control may be built into the system because of trapped air pockets or a water hammer arrestor. In that case the pressure will increase slightly, hold steady for a short time and then rapidly increase. The temperature and pressure relief valve (T&P) or PRV should open and release water once the pressure reaches the maximum setting on the valve. The valve will close once the pressure falls below the pressure setting of the valve.

RESIDENTIAL ELECTRIC WATER HEATER SERVICE HANDBOOK

THE FIX

The ideal fix involves the use of a pressure reducing valve if supply pressures are above 60 to 70 psi, and a properly sized expansion tank. The PRV reduces supply pressures to 40 to 60 psi allowing an economically priced and sized expansion tank to be used. The PRV also offers the benefit of saving water and prolonging the life of water flow valves. The PRV is not required if the system already has one or if high supply pressures are desired.

The PRV is installed between the check valve and the water heating system. The expansion tank is installed between the PRV and the water heating system. Follow the manufacturer's instructions for installing the expansion tank.

Run the thermal expansion check again. The pressure should increase only slightly then hold steady throughout the recovery cycle. The expanded water is flowing back from the heater and into the pressurized storage bladder of the expansion tank. Air pressure will force this water out of the expansion tank into the supply once usage resumes.

DO NOT DEPEND ON THE T&P VALVE TO HANDLE THERMAL EXPANSION! The T&P valve, according to the makers of those valves, was designed as an emergency relief device only. The T&P could be subject to reduced effectiveness or failure.

FIGURE

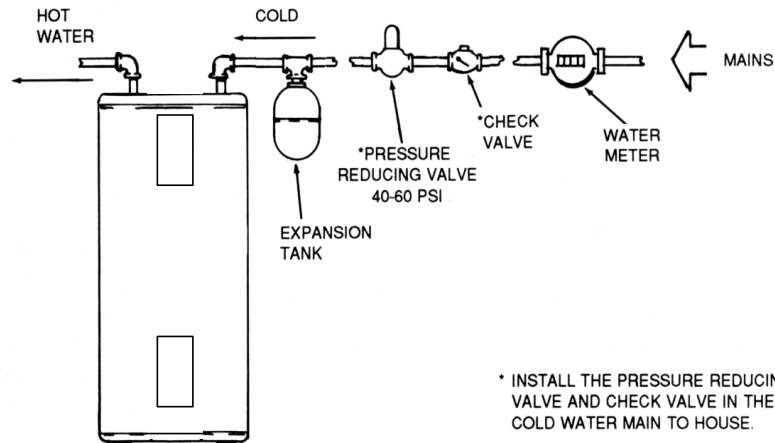

WARNING

Thermal expansion of water, if not compensated for in system design, will lead to the early failure of components. These failures are not covered by the manufacturer's warranty, so it is extremely important that everyone be aware of the causes, symptoms and solutions to thermal expansion in a closed water heating system.

RESIDENTIAL ELECTRIC WATER HEATER SERVICE HANDBOOK

TECHNICAL BULLETIN

BULLETIN 52

LEAKING TEMPERATURE AND PRESSURE RELIEF VALVE

SYMPTOMS

- Water seeping around the relief valve tank connection
- Leakage at the threaded portion of the relief valve connection
- Intermittent weeping and/or dribbling from the relief valve
- Large volume of hot water sporadically discharged from the relief valve

GENERAL

The temperature and pressure relief valve (T & P) is a safety device limiting temperature and pressure levels in a water heater. Each T & P has both a temperature and pressure rating.

Normally, the temperature and pressure relief valve will have a temperature rating for 210°F. A probe (part of the relief valve) extends into the tank measuring the stored water temperature. This probe must be within the top six inches of the water heater. However, if the water heater's thermostat malfunctions, higher than normal water temperatures could be produced. Once the probe senses a temperature exceeding its temperature rating, the relief valve will open to full capacity releasing "very hot" water until the temperature is below its reset temperature.

The pressure rating on the relief valve should be the same or less than the certified working pressure of the tank (generally 150 psi) and be below the lowest pressure rating of any system components. It is not acceptable to install a relief valve that exceeds the maximum working pressure of the water heater. Once the pressure in the tank reaches the valve's pressure rating, it will slightly open relieving the pressure. Relieving of pressure can be noted as "dribbling" or "weeping" water from the relief valve.

If an incorrectly sized temperature and pressure relief valve is installed, the warranty will be void.

THE FIX

- Seeping at the spud of the water heater - Spuds are welded to the tank and are not repairable. The heater should be replaced.
- Leakage at the threaded relief valve connection - Remove relief valve and reseal connection.
- Intermittent weeping and/or dribbling at the relief valve - The relief valve relieves water slowly when actuating on pressure. A closed system can cause pressure to increase in the system. This condition is called thermal expansion. For additional information regarding thermal expansion please see Bulletin 45.
- Large volume of hot water sporadically discharged from the relief valve - The relief valve relieves water quickly when actuating on temperature. The only cause of this problem is a malfunctioning thermostat.

To order additional copies of this Service Handbook and to view other service and presentation literature and CDs that are available from State Water Heaters:

Telephone 1-800-821-2017, Fax number 800-644-9306 or visit our web site at www.statewaterheaters.com

For additional information or assistance in servicing your State water heater, visit our web site or telephone the Technical Information Department at 1-800-365-0024

This Service Handbook was prepared by the Technical Training Department, Ashland City, TN.