

COMMERCIAL GAS HIGH EFFICIENCY WATER HEATERS



500 Tennessee Waltz Parkway
Ashland City, TN 37015

**FOR MODELS:
SUF 60120 THRU SUF 100250
SUF 119300 THRU SUF 119500
SERIES 200/201**

**INSTALLATION CONSIDERATIONS - PRE SERVICE CHECKS -
CONSTRUCTION - OPERATION & SERVICE - TROUBLESHOOTING**



SERVICING SHOULD ONLY BE PERFORMED BY A QUALIFIED SERVICE TECHNICIAN

TABLE OF CONTENTS

INTRODUCTION	2	VENTING.....	33
Qualifications	2	General Venting Information	33
Service Warning	2	INTAKE AIR CONNECTION.....	34
Service Reminder	2	ELECTRICAL CONNECTIONS – ALL MODELS.....	35
Tools Recommended	2	Electrical Wiring.....	35
INSTALLATION CONSIDERATIONS	3	Power Supply Connections	35
Instruction Manual	3	Enable/ Disable Switch.....	36
Closed Water Systems	3	Power Supply Test.....	36
Thermal Expansion.....	3	INSTALLATION CHECK LIST	37
Air Requirements.....	3	OPERATION AND SERVICE	38
Contaminated Air.....	3	How It Works	38
FEATURES AND COMPONENTS	4	Combustion Blower	38
Combustion Blower & Burner Assembly.....	4	Modulation	38
Top View: SUF 60120 - 100250 Models	5	BLOWER SPEED CONTROL – SUF 119300 THRU 119500.....	40
Top View: SUF 119300 - 119500 Models.....	5	VARIABLE FREQUENCY DRIVE – SUF 119300 THRU 119500	41
SEQUENCE OF OPERATION FLOW CHART.....	6	BURNER ASSEMBLY	42
FAULT AND WARNING CODES	7	COMBUSTION BLOWER AND BURNER REMOVAL/ INSTALLATION	
1. Low Gas Pressure	7	INSTRUCTIONS.....	43
High Altitude	7	SPARK IGNITER.....	44
Gas Pressure Specifications	7	GAS ORIFICE - SUF 119300 THRU 119500 MODELS	46
Gas Supply Systems.....	8	Orifice Chart - SUF 119300 thru 119500 Models.....	46
Supply Gas Regulator	8	CCB (CENTRAL CONTROL BOARD).....	47
Gas Pressure Test.....	9	CCB Cover Removal And Replacement.....	48
2. Blower Operation Error.....	11	CCB Circuit Board Layout	49
Pressure Switches	11	CCB Connection Identification.....	50
Control System Monitoring.....	11	WIRING DIAGRAM – SUF 60120 THRU 100250	52
Pressure Switch Tests	12	WIRING DIAGRAM – SUF 119300 THRU 119500.....	53
Continuity Test During Standby.....	12	CONTROL OVERVIEW.....	54
Continuity Test During Operation	13		
Pressure Test During Operation.....	13		
Pressure Switch Settings	14		
3. Blower Prover Open	16		
4. Ignition Failure	17		
5. Blocked Air Intake.....	20		
6. Blocked Exhaust.....	21		
7. Flame Sensor Error	22		
Gas Control Valve	22		
Gas Control Valve Voltage Tests	23		
Flame Sensor.....	24		
Flame Sensing Operation	24		
Flame Sensing Current Test.....	25		
8. No Water.....	26		
Powered Anodes	26		
Power anode cleaning and removal.....	26		
9. Anode Shorted.....	28		
10. Temperature Probe Short (Upper or Lower)	29		
Temperature Probe	29		
Temperature Sensor Test.....	30		
ECO Continuity Test.....	30		
11. Temperature Probe Open (Upper or Lower)	32		

INTRODUCTION

This Service Handbook covers the water heater Model and Series numbers listed on the front cover only. The instructions and illustrations contained in this service handbook will provide you with troubleshooting procedures to verify proper operation and diagnose and repair common service problems.

QUALIFICATIONS

QUALIFIED INSTALLER OR SERVICE AGENCY

Installation and service of this water heater requires ability equivalent to that of a Qualified Agency (as defined by ANSI below) in the field involved. Installation skills such as plumbing, air supply, venting, gas supply and electrical supply are required in addition to electrical testing skills when performing service.

ANSI Z223.1 2006 Sec. 3.3.83: "Qualified Agency" - "Any individual, firm, corporation or company that either in person or through a representative is engaged in and is responsible for (a) the installation, testing or replacement of gas piping or (b) the connection, installation, testing, repair or servicing of appliances and equipment; that is experienced in such work; that is familiar with all precautions required; and that has complied with all the requirements of the authority having jurisdiction."

SERVICE WARNING

If you are not qualified (as defined by ANSI above) and licensed or certified as required by the authority having jurisdiction to perform a given task do not attempt to perform any of the procedures described in this service handbook. If you do not understand the instructions given in this service handbook do not attempt to perform any procedures outlined in this service handbook.

SERVICE REMINDER

When performing any troubleshooting step outlined in this service handbook always consider the wiring and connectors between components. Perform a close visual inspection of all wiring and connectors to and from a given component before replacement. Ensure wires were stripped before being crimped in a wire connector, ensure wires are crimped tightly in their connectors, ensure connection pins in sockets and plugs are not damaged or worn, ensure plugs and sockets are mating properly and providing good contact.

Failure to perform this critical step or failing to perform this step thoroughly often results in needless down time, unnecessary parts replacement, and customer dissatisfaction.

TOOLS RECOMMENDED

- Instruction Manual that came with the water heater.
- All tools common to installation and service of commercial water heaters such as hand tools, screwdrivers, pipe wrenches etc.
- Long (8-10") T handle 1/8 inch hex (allen key) wrench for Combustion Blower removal and installation.
- Hex (Allen) wrench sizes: 5/32", 1/8", 1/4" and 5/16" - for Burner, and 24 Volt Gas Control Valve removal and installation.
- Digital manometer: Range -20.00 to +20.00" W.C. Resolution - 0.01" W.C. Required to test pressure switch performance and supply gas pressure.
- Digital Multi Meter; capable of measuring:
 - AC/DC Voltage.
 - Ohms.
 - DC micro amps (μ A) - flame sensing current, see "Flame Sensing Current Test" on Page 25.

INSTALLATION CONSIDERATIONS

This section of the Service Handbook covers some of the critical installation requirements that, when overlooked, often result in operational problems, down time and needless parts replacement. Costs to correct installation errors are not covered under the limited warranty. Ensure all installation requirements and instructions contained in the Instruction Manual that came with the water heater have been followed prior to performing any service procedures.

INSTRUCTION MANUAL

Have a copy of the Instruction Manual that came with the water heater on hand for the model and series number being serviced. Installation information given in this Service Handbook is not a complete installation instruction. Installation information given in this Service Handbook has a limited focus as it applies to servicing the water heater. This Service Handbook does not replace or supersede the Instruction Manual that came with the water heater. Always refer to the Instruction Manual for complete installation instructions. If the Instruction Manual is not on hand, copies can be obtained from the manufacturers web site or by calling the technical support phone number shown on the back cover of this Service Handbook.

CLOSED WATER SYSTEMS

Water supply systems may, because of code requirements or such conditions as high line pressure, among others, have installed devices such as pressure reducing valves, check valves, and back flow preventers. Devices such as these cause the water system to be a closed system.

THERMAL EXPANSION

As water is heated, it expands (thermal expansion). In a closed system the volume of water will grow when it is heated. As the volume of water grows there will be a corresponding increase in water pressure due to thermal expansion. Thermal expansion can cause premature tank failure (leakage). This type of failure is not covered under the limited warranty. Thermal expansion can also cause intermittent Temperature-Pressure Relief Valve operation: water discharged from the valve due to excessive pressure build up. This condition is not covered under the limited warranty. The Temperature-Pressure Relief Valve is not intended for the constant relief of thermal expansion.

A properly sized thermal expansion tank must be installed on all closed systems to control the harmful effects of thermal expansion. Contact a local plumbing service agency to have a thermal expansion tank installed.

AIR REQUIREMENTS

Carefully review the requirements for combustion and ventilation air in the Instruction Manual that came with the water heater. Failure to meet these requirements when the water heater is installed or overlooking their importance when servicing the water heater often results in needless down time, unnecessary parts replacement, and customer dissatisfaction.

An inadequate supply of air for combustion and ventilation often causes operational problems. A lack of combustion and ventilation air can create a negative ambient air pressure in the installed space which can lead to improper combustion and operational problems with pressure switches.

CONTAMINATED AIR

Combustion air that is contaminated can greatly diminish the life span of the water heater and water heater components such as Igniters and Burners. Propellants of aerosol sprays, beauty shop supplies, water softener chemicals and chemicals used in dry cleaning processes that are present in the combustion, ventilation or ambient air can cause such damage.

Vapors from volatile compounds such as solvents, cleaners, chlorine based chemicals and refrigerants in addition to being highly flammable in many cases, can also react to form highly corrosive substances such as acids inside the combustion chamber. The results can be hazardous and cause product failure.

If the water heater is installed in beauty shops, barber shops or laundries with dry cleaning equipment, it is imperative the water heater be installed in a Direct Vent configuration so that air for combustion is derived directly from the outdoor atmosphere through a sealed intake air pipe. See the venting installation section in the Instruction Manual that came with the water heater for more information on Direct Vent installations.

FEATURES AND COMPONENTS

COMBUSTION BLOWER & BURNER ASSEMBLY

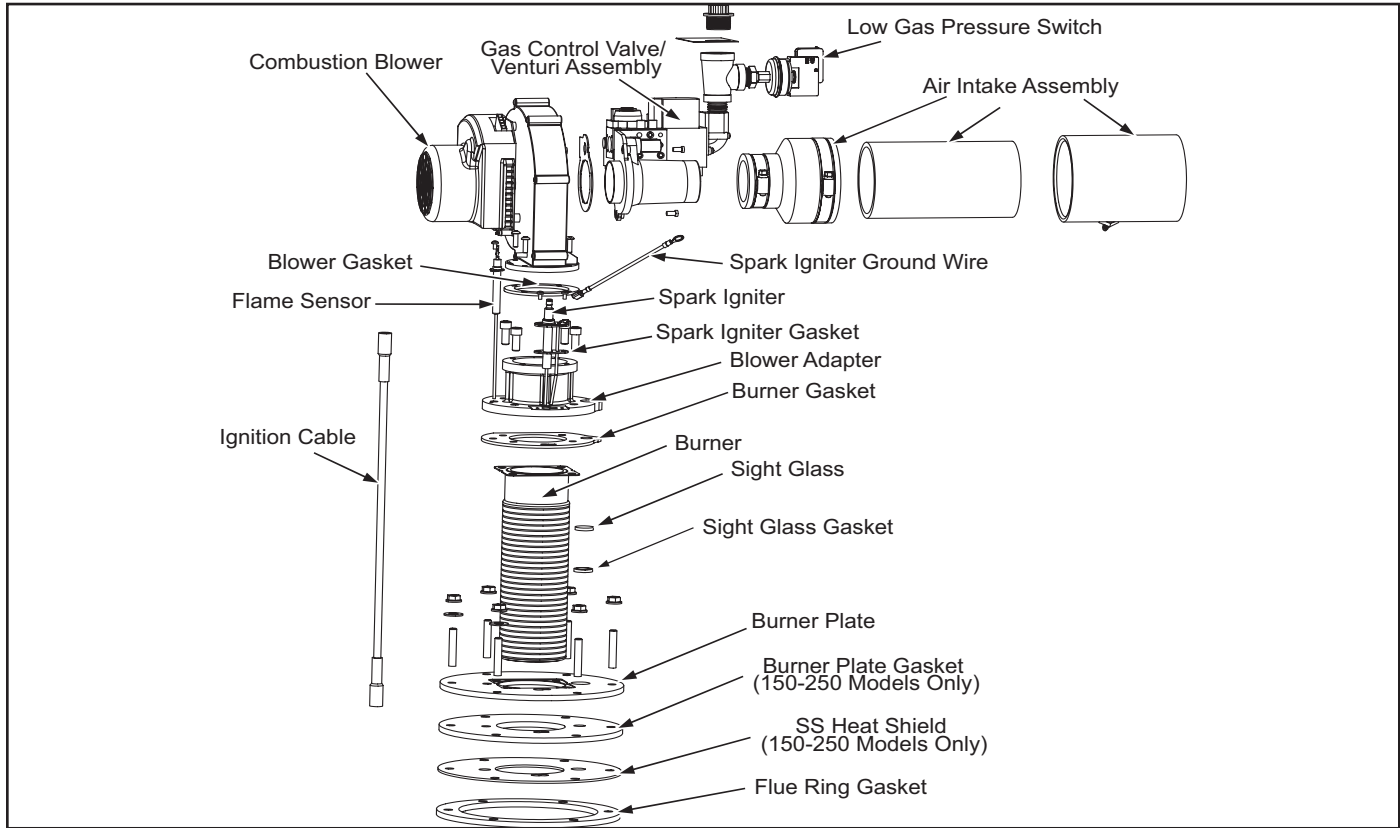

SUF 60120 - 100250 Models

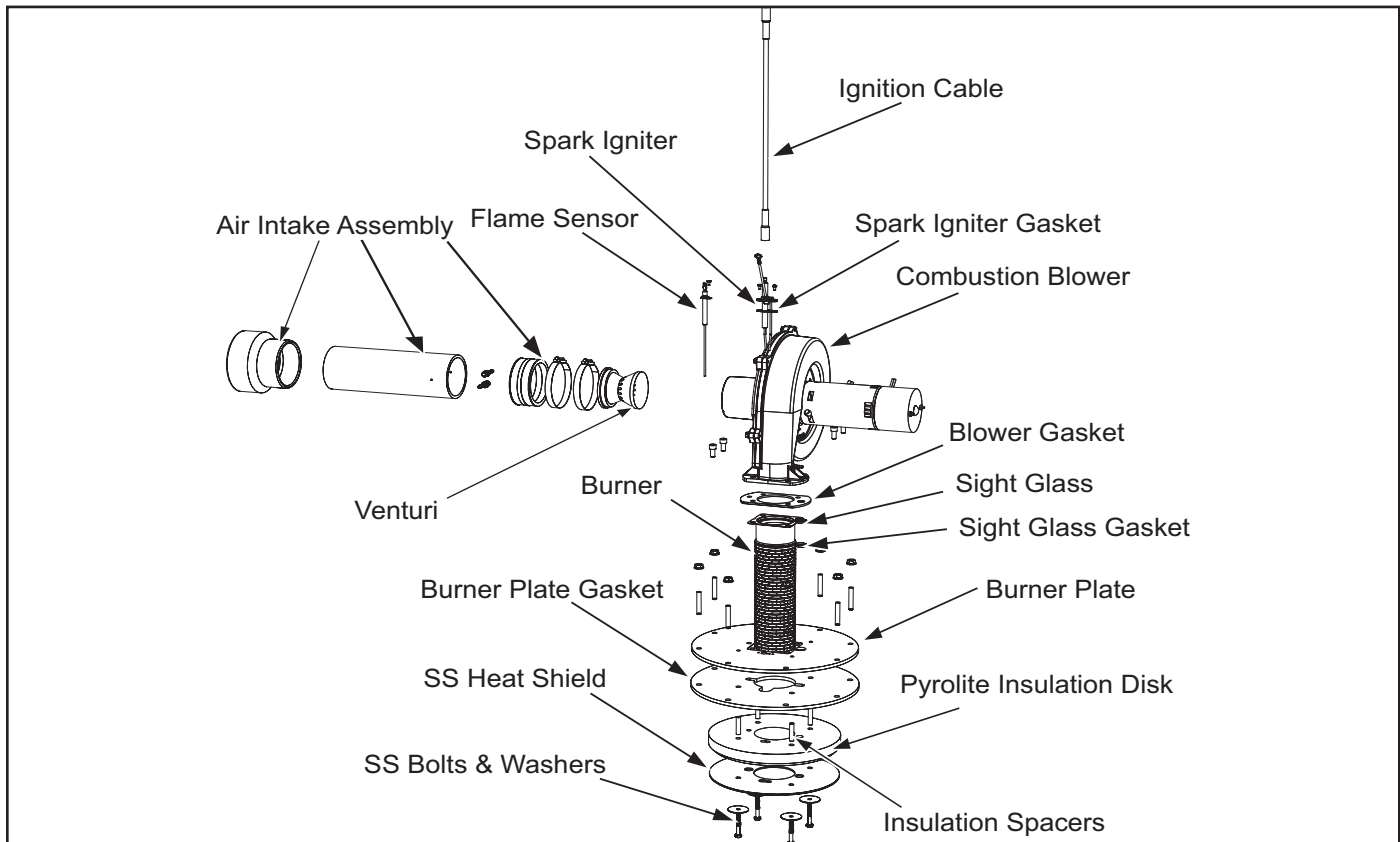

SUF 119300 - 119500 Models

TOP VIEW: SUF 60120 - 100250 MODELS

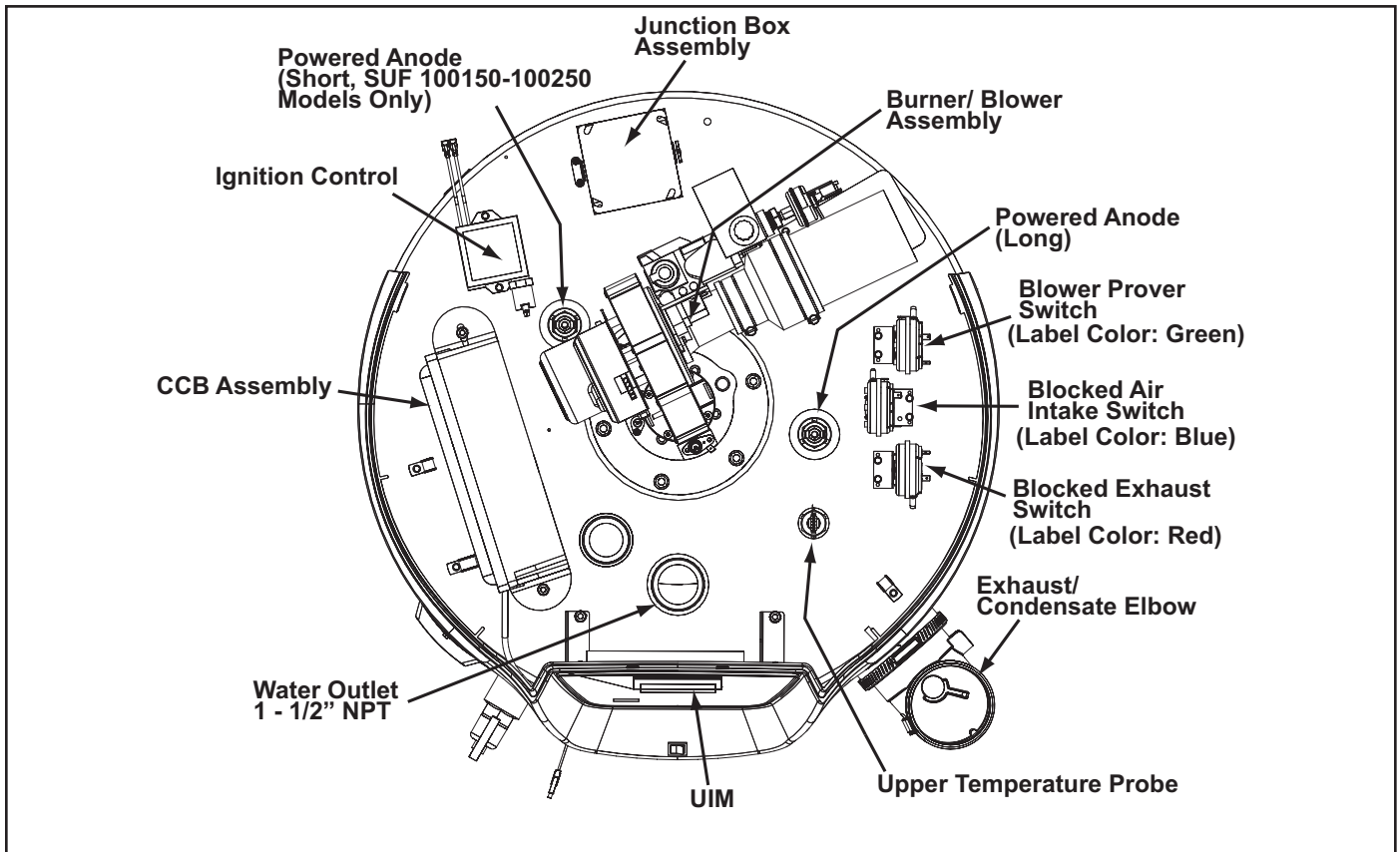

TOP VIEW: SUF 119300 - 119500 MODELS

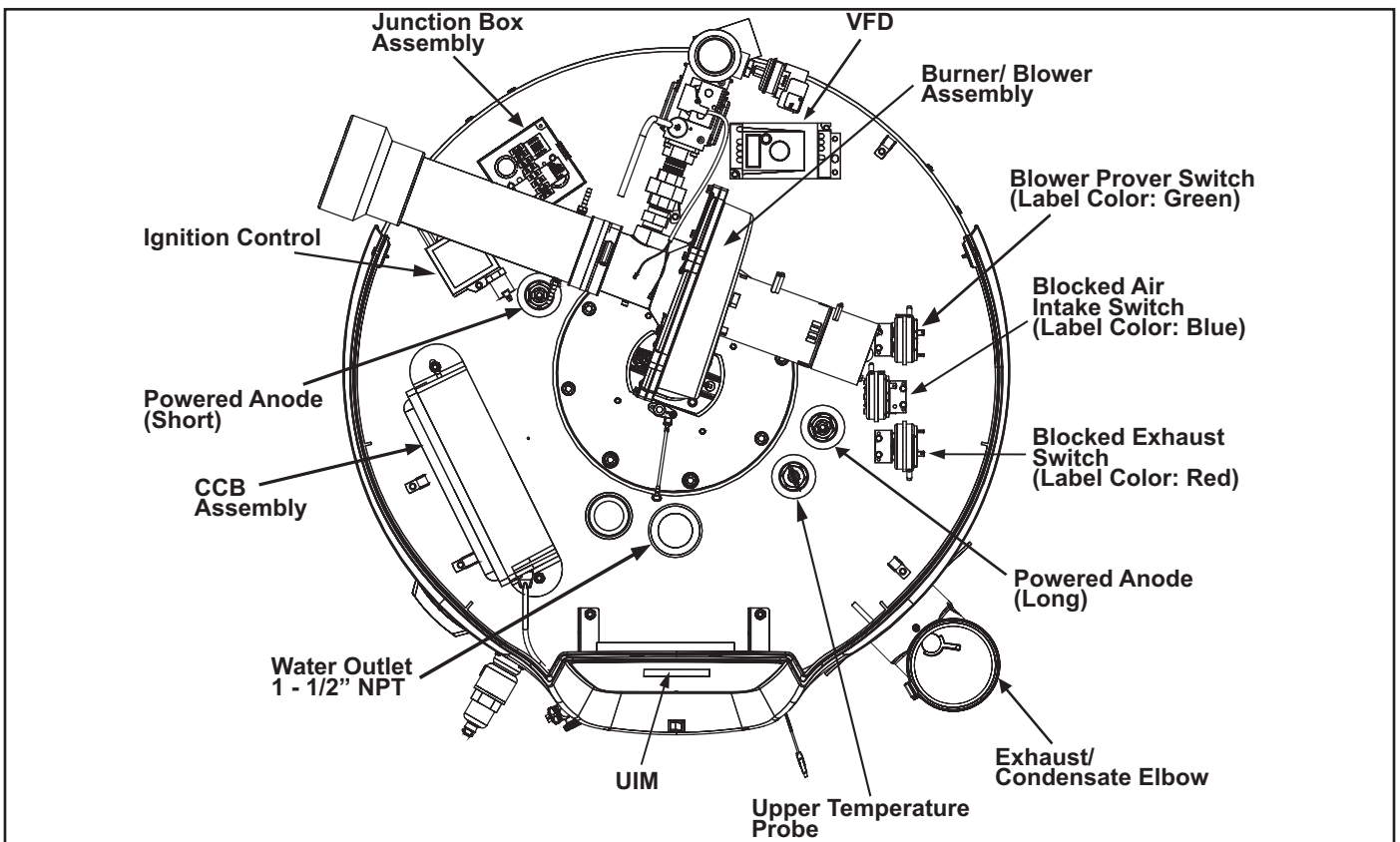

SEQUENCE OF OPERATION FLOW CHART

Sequence is shown with Enable/Disable Switch in the Enable position

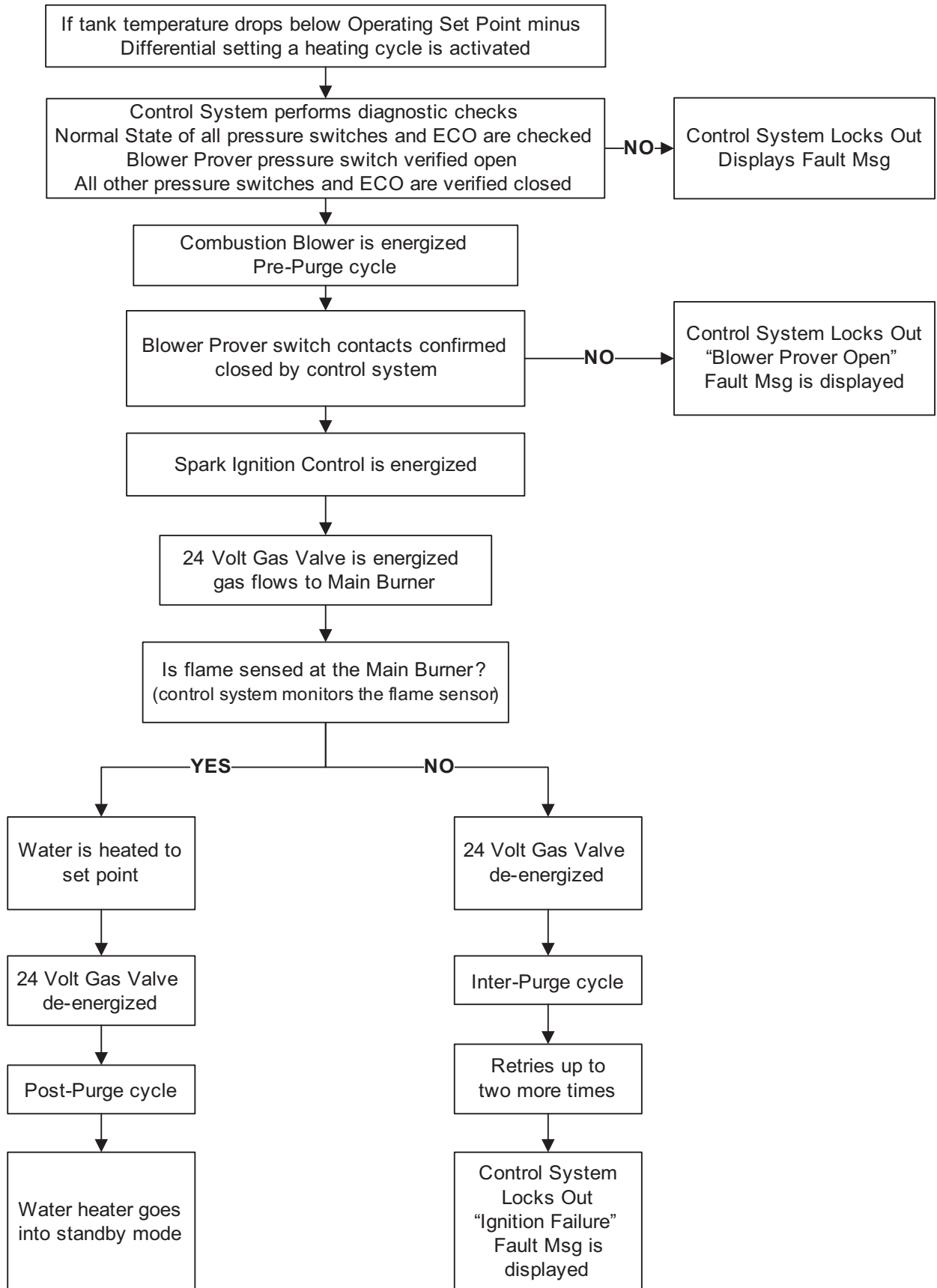

FAULT AND WARNING CODES

1. LOW GAS PRESSURE

Low Gas Pressure

Fault occurred 2 mins ago

Gas pressure is below minimum required to operate this unit. Check gas pressure and switch.

Call a service professional:
Your Company Name Here
(press [DOWN] for more....)



BACK
ADVANCED

CAUSES:

- The Low Gas Pressure Switch is detecting gas pressure below the value required for proper operation.

CHECK/ REPAIR:

- Check Low Gas Pressure Switch wiring and connectors. Connectors must be clean and tight.
- Determine proper minimum pressure from rating plate.
 - Use manometer or gauge to check gas pressure during all stages of operation with all other appliances firing.
 - If pressure falls below rating plate requirement, supply pipe may be too small for application or supply regulator may be operating improperly. See Gas Pressure section below.

HIGH ALTITUDE

The water heaters covered in this Service Handbook are certified for elevations up to 10,100 feet (3,078 meters). For higher elevations call the toll free support phone number shown on the back cover of this Service Handbook for technical assistance.

GAS PRESSURE SPECIFICATIONS

MODELS	Natural 60120-100250	Propane 60120-100250	Natural 119300/119400/119500	Propane 119300/119400/119500
Maximum Gas Supply Pressure	14.0" WC (3.49 kPa)	14.0" WC (3.49 kPa)	14.0" WC (3.49 kPa)	14.0" WC (3.49 kPa)
Nominal Gas Supply Pressure	7.0" WC (1.74 kPa)	11.0" WC (2.74 kPa)	7.0" WC (1.74 kPa)	11.0" WC (2.74 kPa)
Minimum Gas Supply Pressure (Low Gas Press. Switch Setting)	4.4" WC (1.10 kPa)	8.5" WC (2.12 kPa)	4.8" WC (1.19 kPa)	8.5" WC (2.12 kPa)
*Manifold Pressure	0" WC (0 kPa)	0" WC (0 kPa)	0" WC (0 kPa)	0" WC (0 kPa)

*The Manifold Pressure is the factory setting and is not adjustable. A negative pressure will be seen with just the blower running without the Gas Control Valve open.

GAS SUPPLY SYSTEMS

Low pressure building gas supply systems are defined as those systems that cannot under any circumstances exceed 14" W.C. (1/2 PSI Gauge). These systems do not require additional pressure regulation. Measurements should be taken to insure that gas pressures are stable and fall within the requirements stated on the water heater rating plate. Readings should be taken with all gas burning equipment off (static pressure) and with all gas burning equipment running at maximum rate (dynamic pressure). The gas pressure supplied to this unit must be below the maximum and above the minimum pressures listed on the unit's rating plate and must not drop more than 1.5" W.C. when unit is operating at the high fire rate along with all additional gas appliances operating on the same gas supply system. Pressure drops that exceed 1.5" W.C. may cause rough starting, noisy combustion or nuisance outages. Increases or spikes in static pressure during off cycles may cause failure to ignite or in severe cases damage to appliance Gas Control Valves. If your low pressure system does NOT meet these requirements, do not operate this unit. The installer is responsible for ensuring that the gas supply pressures meet the requirements described above and listed in the table. Failure of the gas supply to meet these requirements is not covered under the warranty.

High Pressure building supply systems use pressures that exceed 14" W.C. (1/2 PSI Gauge). These systems must use field supplied regulators to lower the gas pressure to less than 14" W.C. (1/2 PSI Gauge). Water heaters require gas regulators that are properly sized for the water heater's BTU input and capable of delivering the rating plate specified pressures. Gas supply systems where pressure exceeds 5 PSI often require multiple regulators to achieve desired pressures. Systems in excess of 5 PSI building pressure should be designed by gas delivery professionals for best performance. Water heaters connected to gas supply systems that exceed 14" W.C. (1/2 PSI Gauge) must be equipped with a gas supply regulator capable of preventing the gas supplied to the unit from exceeding 14" W.C. under any upstream supply pressure or condition.

For Natural Gas SUF 60120 - 100250 models require a minimum gas supply pressure of 4.4" W.C., SUF 119300 - 119500 models require 4.8" W.C., and all models require 8.5" W.C. for propane gas. The minimum supply pressure is measured while gas is flowing (dynamic pressure) along with all additional gas appliances operating on the same gas supply system. The supply pressure should be measured with all gas fired appliances connected to the common main firing at full capacity. If the supply pressure drops more than 1.5" W.C. (0.05 PSI Gauge) when the water heater is operating at high fire rate, then the supply gas system including the gas line and/or the gas regulator may be restricted or undersized. See Supply Gas Regulator section below. The Gas Control Valve on all models has a maximum gas supply pressure limit of 14" W.C. (1/2 PSI Gauge). The maximum supply pressure is measured while gas is not flowing (static pressure) to any appliances connected to the same gas supply system.

SUPPLY GAS REGULATOR

The maximum allowable gas supply pressure for the water heaters covered in this Service Handbook is 14.0 inches W.C. (3.49 kPa) for natural and propane gas. Install a positive lock-up gas pressure regulator in the gas supply line if inlet gas pressure can exceed these pressures at any time. Regulators must be sized to equal or exceed the BTU input requirements of the heater model and installed, used, and maintained according to manufacturer's specifications.

If a positive lock-up regulator is installed follow these instructions:

1. Positive lock-up gas pressure regulators must be rated at or above the input Btu/hr rating of all the gas appliances that are on the same system as the water heater.
2. Supply gas regulators shall have inlet and outlet connections not less than the minimum supply gas line size for the water heater they supply.
3. Refer to the gas pressure regulator's manufacturers installation instructions to determine its installation location requirements.
4. After installing the positive lock-up gas pressure regulator(s) an initial nominal supply pressure setting of 7.0" W.C. (1.74 kPa) for Natural Gas and 11.0" W.C. (2.74 kPa) for Propane (LP) while the water heater is operating is recommended and will generally provide good water heater operation. Adjustments to the regulator maybe required to maintain a steady gas supply pressure.

- When installing multiple water heaters in the same gas supply system it is recommended that individual positive lock-up gas pressure regulators be installed at each unit from the supply gas connection on the water heater.

Service notes:

- The manifold gas pressure is factory set and cannot be adjusted in the field.
- There are two pressure test ports on the water heater's 24 Volt Gas Control Valve, see Figure below. The Gas Control Valve outlet pressure test port is closest to the Combustion Blower, see Figure below. There is a needle valve in each test port that is opened/closed with a small slotted screwdriver. Turn the needle valve counter-clockwise to open the test port valve and clockwise to close it.
- The hose from the Gas Control Valve supply gas pressure test port should be connected to the positive pressure port of a manometer; the other pressure port of a manometer should be left open.
- There is usually a drop in supply gas pressure noticed when the water heater's 24 Volt Gas Control Valve opens during ignition. The manifold pressure will go from a negative value (during pre-purge) to near zero when gas is flowing.
- A sustained drop in supply gas pressure of 1.5" W.C. or more during ignition may indicate the supply gas line is undersized. If the water heater is experiencing a sustained drop in supply gas pressure of 1.5" W.C. or more and the water heater is experiencing repeated **Ignition Failure** fault conditions, intermittent loss of flame or rough starting ensure the supply gas line is sized in accordance with the current edition of National Fuel Gas Code (ANSI Z223.1/NFPA 54) or the Natural Gas and Propane Installation Code (CAN/CSA B149.1).

GAS PRESSURE TEST

- Use the Enable/Disable Switch located on the front of the water heater and put the unit in disabled mode.
- Turn off the supply gas to the water heater at the main gas shutoff valve serving the water heater.
- Open the Supply Gas Pressure Test Port on the Gas Control Valve, see Figures below. Turn the needle valve slotted head 1/2 to 1 full turn counter-clockwise with a small slotted screwdriver to open the valve.
- A digital manometer (see "Tools Recommended" on Page 2) is needed to check supply gas pressure. To monitor supply gas pressure, attach a sensing tube from Gas Control Valve Supply Gas Pressure Test Port to one digital manometer.
- Open the main gas shutoff valve serving the water heater.
- The manometer connected to the Supply Gas Pressure Test Port should read the "static" (gas is not flowing) supply gas pressure.

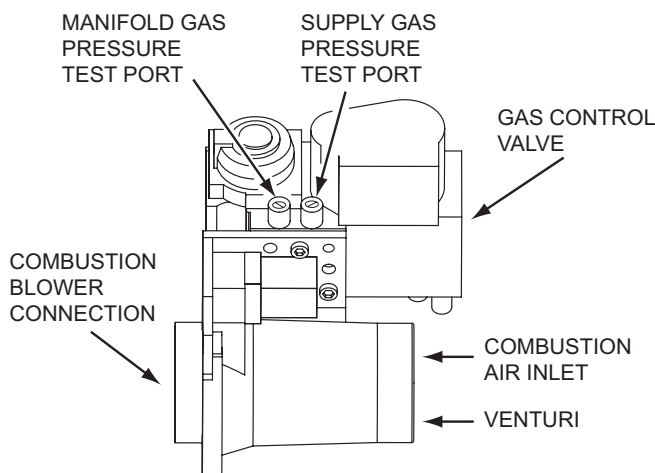

SUF 60120 - 100250 Models

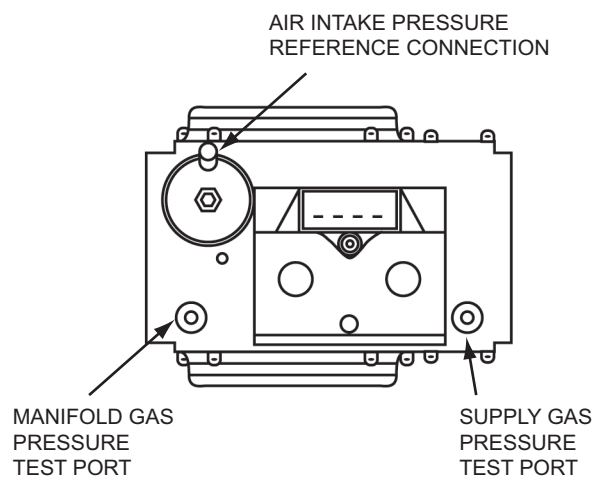

SUF 119300 - 119500 Models

7. Record the supply gas pressure.
8. Use the Enable/Disable Switch located on the front of the water heater and put the unit in enabled mode. The settings on the water heater may need to be changed to cause the water heater to operate. Note the Operating Temperature Set Point so that the unit can be returned to this setting at the conclusion of this test procedure. Increase the Operating Set Point if necessary to cause the water heater to have a call for heat.
9. Record the supply gas pressure when the Ignition Activation operating state begins; when the animated Gas Control valve Status Icon appears on the UIM Screen.
 - The supply gas pressure will typically drop as the Gas Control Valve opens.

Putting The Water Heater Back In Service

10. Lower the Operating Set Point to end the heating cycle. Use the Enable/Disable Switch located on the front of the water heater and put the unit in disabled mode.
11. Close the main gas shutoff valve serving the water heater.
12. Disconnect manometer sensing tube.
13. Close the Supply Gas Pressure Test Port on the Gas Control Valve. Turn the needle valve slotted head clockwise until tight.
14. Open the main gas shutoff valve serving the water heater and check for leaks at the Gas Control Valve test ports.
15. Use the Enable/Disable Switch located on the front of the water heater and put the unit in enabled mode. Increase the Operating Set Point if necessary to cause the water heater to have a call for heat.
16. Run the water heater through a complete heating cycle before leaving to ensure it is operating properly. Return the Operating Set Point Temperature to its original setting. Draw water from the nearest faucet to make sure that the water temperature does not pose a scalding hazard due to the increased temperature set points that were used in this procedure.

2. BLOWER OPERATION ERROR

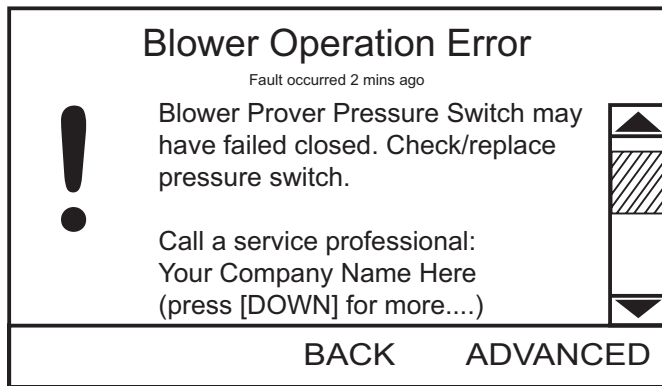

CAUSES:

- The Blower Prover Pressure Switch was detected closed before blower operation.

CHECK/ REPAIR:

- This switch is normally open and is used to prove blower operation. This switch should be open when blower is not running. Check continuity of pressure switch. See "Pressure Switch Tests" section on Page 12 thru Page 15.

PRESSURE SWITCHES

The water heaters covered in this Service Handbook are factory equipped with four pressure switches (including the Low Gas Pressure Switch). "Top View" Figures on Page 5 shows the location of the three pressure switches on top of the water heater. This section of the Service Handbook covers pressure switch construction, operation and the test procedures used to diagnose operational problems associated with pressure switches. The pressure switches are identified with colored labels; Blower Prover Switch is Green, Blocked Air Intake Switch is Blue, & Blocked Exhaust Switch is Red.

CONTROL SYSTEM MONITORING

The Control System monitors the "state" of the pressure switch contacts individually through three separate circuits, see "Wiring Diagrams" on Page 52 & Page 53. The state of the switch refers to whether the switch contacts are open or closed.

At the beginning of a heating sequence, before the Combustion Blower is energized, the Control System enters the Input Verification operating state. During Input Verification the Control System monitors all three pressure switches to ensure their contacts are in the correct "normal" state. The Blower Prover switch contacts must be open. The contacts for the Blocked Air Intake Switch and Blocked Exhaust Switches must be closed.

If any of the pressure switch contacts are not in their correct normal state during Input Verification the Control System will lock out and display a fault message on the UIM indicating which pressure switch caused the fault condition. If all system checks pass during the Input Verification operating state the Control System enters the Pre-Purge operating state and energizes the Combustion Blower. The Heater Status Screen and functionality of the water heater can be used for troubleshooting.

After the Combustion Blower is energized the Control System must confirm the Blower Prover switch contacts have closed, see the "Sequence Of Operation Flow Chart" on Page 6. The Blocked Air Intake Switch and Blocked Exhaust Switch contacts must remain closed at all times.

If the Blower Prover switch contacts are closed during the Input Verification the Control System will lock out and display **Blower Prover Failure** on the UIM. If the Blower Prover switch contacts do not close after the Combustion Blower is energized the Control System will lock out and display **Blower Prover Open** on the UIM. If either the Blocked Air Intake Switch or Blocked Exhaust Switch contacts open at any time during a heating sequence the Control System will lock out and display **Blocked Air Intake** or **Blocked Exhaust** on the UIM. Wires connecting to air switches are labeled near the terminals. Ensure no mis-wiring among terminals.

PRESSURE SWITCH TESTS

Complete pressure switch testing involves three procedures:

- "Continuity Test During Standby" below.
- "Continuity Test During Operation" on Page 13.
- "Pressure Test During Operation" on Page 13 thru Page 15.

CONTINUITY TEST DURING STANDBY

This test is performed while the Combustion Blower is not running with the water heater turned off. This is a "normal state" continuity test of the contacts inside each pressure switch. Disconnect the two wires to each pressure switch for this test.

1. If the water heater is in a heating cycle lower the Operating Set Point to end the cycle.
2. Turn off the circuit breaker that serves the water heater.
3. Disconnect both wires at each pressure switch.
4. Using an ohm meter set for continuity testing, check for continuity between the two wiring terminals at each pressure switch, see Figure below.
5. After completing the tests, confirm that all of the pressure switch wires are reconnected including the replacement part if necessary based on the Results/Actions listed below. Restore the electrical power to the water heater. Reset the Operating Temperature Set Point if it was adjusted. Run the water heater through a complete heating cycle before leaving to ensure it is operating properly.

Results/Actions

Passed Results: If the Blower Prover switch contacts are open during this test (infinite ohms/open circuit) the Blower Prover switch has passed the test. If the Blocked Air Intake Switch and Blocked Exhaust Switch contacts are closed during this test, (zero ohms/direct short), these switches have passed the test.

Failed Results: If the Blower Prover switch contacts are closed (zero ohms/direct short/beep) during this test, the Blower Prover switch must be replaced. If the Blocked Air Intake Switch and/or Blocked Exhaust switch contacts are open during this test, the switch(s) must be replaced.

Proceed to the Continuity Test During Operation on next page.

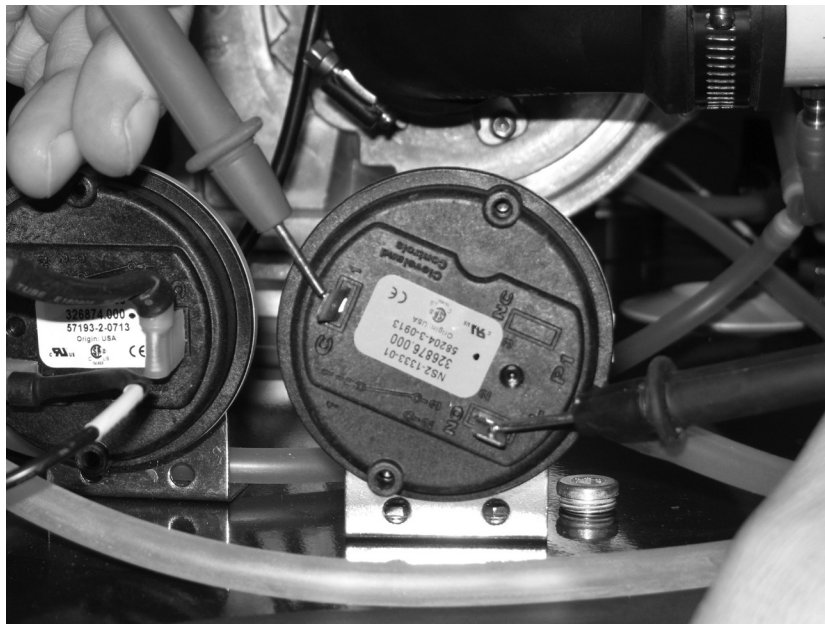

CONTINUITY TEST DURING OPERATION

This test is performed while the Combustion Blower is running at high speed during the Pre-Purge operating state. The test is performed on all three pressure switches. Disconnect the two wires to each pressure switch - one at a time, check continuity and then reconnect the wires to that switch before testing the next switch.

1. Turn off the circuit breaker that serves the water heater.
2. Ensure the sensing tubes from each pressure switch are connected to the correct sensing port on the water heater.
3. Disconnect the two wires for the switch to be tested.
4. When testing the Blocked Exhaust and Blocked Air Intake Switches, connect a jumper wire between the two wires disconnected. This will temporarily prevent the Control System from locking out during the test. When the test for these two switches is complete, remove the jumper wire and reconnect the pressure switch wiring before moving on to the next switch.
5. Restore power to the water heater, if the water heater does not begin a heating cycle raise the Operating Set Point to activate a heating cycle.
6. Using an ohm meter set for continuity testing, check for continuity between the two wiring terminals at the pressure switch after the Combustion Blower has started and ramped up to high speed during the Pre-Purge operating state. Record the results; open or closed.
7. Repeat this procedure for each pressure switch.
8. Turn off the circuit breaker that serves the water heater. Confirm that all of the pressure switch wires are reconnected including the replacement part if necessary based on the Results/Actions listed below. Restore the electrical power to the water heater. Reset the Operating Temperature Set Point if it was adjusted. Run the water heater through a complete heating cycle before leaving to ensure it is operating properly. Draw water from the nearest faucet to make sure that the water temperature does not pose a scalding hazard due to the increased temperature set points that were used in this procedure.

Results/Actions

Passed Results: If the Blower Prover switch contacts activate/close (zero ohms/direct short) during this test the switch has passed this test. If the Blocked Air Intake Switch and Blocked Exhaust Switch contacts remain closed during this test, (zero ohms/direct short), these switches have passed the test.

Failed Results: If the Blower Prover switch contacts do not close during this test, the Pressure Test During Operation below must be performed to determine if the switch is defective. If the Blocked Air Intake Switch or Blocked Exhaust switch contacts open during this test, the Pressure Test During Operation below must be performed to determine if the switch(s) is defective. Proceed to the Pressure Test During Operation below.

PRESSURE TEST DURING OPERATION

This test will be performed while the Combustion Blower is running at high speed during the Pre-Purge operating state. This test is necessary when a pressure switch has passed the "Continuity Test During Standby" shown on Page 12 but has failed the Continuity Test During Operation above to determine if the pressure switch is defective or not. This test requires a digital manometer, see "Tools Recommended" on Page 2.

Service Notes:

- Before performing this test examine the sensing tube connections on the water heater's sensing ports and on the pressure switch. Check for wear, cracks, leaks, kinks, or any kind of debris or condensate in the sensing tubes, repair/replace as necessary.
- To determine if a pressure switch is operating properly you must first know the "switch action" (whether the switch activates on a rise or a fall in pressure) and the "activation pressure" the switch will activate at. Activation pressures are provided in "Pressure Switch Settings" Table on Page 14. Switch actions are as follows:

- Blower Prover Switch - normally open contacts, close on a rise in pressure.
- Blocked Air Intake Switch - normally closed contacts, open on a fall in pressure.
- Blocked Exhaust Switch - normally closed contacts, open on a rise in pressure.

Activation Pressures: Pressure Switch Settings Table below shows the activation pressures and tolerance for each of the three pressure switches. A + sign before the pressure indicates a positive pressure; above atmospheric pressure. A - sign before the pressure indicates a negative pressure (in a vacuum); below atmospheric pressure. Tolerances are specified to allow reasonable leeway for imperfections and inherent variability without compromising performance.

PRESSURE SWITCH SETTINGS

Models	Blower Prover (+/- 0.05" WC)	Blocked Air Intake (+/-0.05" WC)	Blocked Exhaust (+/-0.05" WC)	Low gas (+/-0.04" WC Nat/ +/-0.05" WC LP)
SUF 60120	0.75" W.C.	-2.50" W.C.	2.00" W.C.	4.4" W.C. Nat/8.5" W.C. LP
SUF 100150 - 100250	1.00" W.C.	-2.50" W.C.	2.00" W.C.	4.4" W.C. Nat/8.5" W.C. LP
SUF 119300 - 119500	1.00" W.C.	-2.30" W.C.	2.00" W.C.	4.8" W.C. Nat/8.5" W.C. LP

Pressure Test:

1. Turn off the circuit breaker that serves the water heater.
2. Disconnect the sensing tube from the switch being tested and add a 3/16" tee to the sensing tube. Add a short piece of sensing tube connecting the tee and the pressure switch being tested.
3. Connect a digital manometer to the open side of the tee with another piece of sensing tube.
4. Restore power to the water heater, if the water heater does not begin a heating cycle raise the Operating Set Point to activate a heating cycle.
5. When the Combustion Blower comes on and ramps up to full speed, record the pressure reading.
6. Repeat this test for all three pressure switches as necessary.
7. Compare the pressure readings taken to the activation pressures in the Table above.
8. Ensure all sensing tubes are properly routed and reconnected when testing is complete. The pressure switches will not operate properly if there are leaks in the tubing. Reset the Operating Temperature Set Point if it was adjusted. Run the water heater through a complete heating cycle before leaving to ensure it is operating properly. Draw water from the nearest faucet to make sure that the water temperature does not pose a scalding hazard due to the increased temperature set points that were used in this procedure.

Results/Actions

Blower Prover: If the pressure reading taken at the Blower Prover switch sensing tube is at or above the activation pressure shown in the above Table **AND** the switch contacts did not close during the "Continuity Test During Operation" shown on Page 13 - the switch is defective and must be replaced. If the pressure reading taken does not reach or rise above the activation pressure in the above Table the pressure switch **IS NOT** defective and should not be replaced - call the toll free phone number on the back cover of this Service Handbook for further technical assistance. Have the complete Model, Series and Serial number (located on the water heater's rating label) for the water heater being serviced on hand before calling.

Blocked Air Intake: Note these are negative pressures; in a vacuum. If the pressure reading taken at the Blocked Air Intake Switch sensing tube does not reach or drop lower than the pressure shown in the above Table **AND** the switch contacts were opening during the "Continuity Test During Operation" shown on Page 13 - the switch is defective and must be replaced. If the pressure reading taken reaches or drops lower than the pressure shown in the "Pressure Switch Settings" Table on Page 14 and the switch contacts were opening during the "Continuity Test During Operation" shown on Page 13 - the switch **IS NOT** defective and should not be replaced. Check for restrictions at the intake air connection on the water heater, check for too small of pipe installed, too many equivalent feet and/or too many elbows in the intake air piping. Check for low points in the intake air piping where water may be collecting and blocking the intake air piping. Check for any restrictions or debris at the intake air termination outdoors. Check for condensate/water in the sensing tube/switch, if the sensing tube has water in it, replace the Blocked Air Intake Switch and the tube. Ensure the sensing port is oriented properly, see "Intake Air Connection" on Page 34.



Blocked Exhaust: If the pressure reading taken at the Blocked Exhaust switch sensing tube does not reach or rise above the activation pressure given in the above Table **AND** the switch contacts were opening during the "Continuity Test During Operation" on Page 13 - the switch is defective and must be replaced. If the pressure reading taken reaches or exceeds the pressure shown in the "Pressure Switch Settings" Table on Page 14 and the switch contacts were opening during the "Continuity Test During Operation" on Page 13 - the switch **IS NOT** defective and should not be replaced. Ensure the condensate drain connected to the exhaust elbow on the water heater is not clogged and is draining freely. Check for restrictions or blockage in the vent pipe, check for too small of pipe installed, too many equivalent feet and/or too many elbows in the vent piping. Check for low points in the vent pipe where water may be collecting and blocking the vent piping. Check for any restrictions or debris at the vent termination outdoors.

3. BLOWER PROVER OPEN

Blower Prover Open
Fault occurred 2 mins ago

 The blower prover switch remains open after the blower has been energized.

Call a service professional:
Your Company Name Here
(press [DOWN] for more....)

BACK ADVANCED

CAUSES:

- The control has detected an open Blower Prover Pressure Switch during operation.
- Blower Prover Pressure Switch sensing tube disconnected or kinked.
- Loose or open wiring connections to Blower Prover Pressure Switch.
- Blower not running when expected.
- Blower Prover Pressure Switch not operating (Replace Blower Prover Switch).

CHECK/ REPAIR:

- The blower prover pressure switch will close its contacts on a pressure rise. See "Pressure Switch Tests" section on Page 12 thru Page 15 under "Blower Operation Error" on Page 11.

4. IGNITION FAILURE

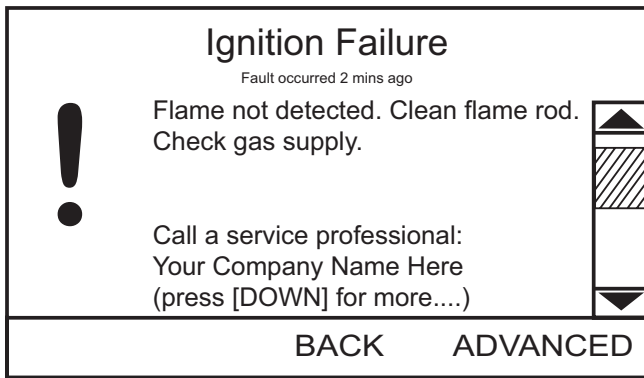

CAUSES:

- On an "Ignition Failure" error, either the burner is not igniting or the burner is igniting, but the Flame Sensor is not detecting ignition (flame).

CHECK/ REPAIR

- Determine whether or not the burner is igniting by looking through sight glass. Because the control system will shut off the Gas Control Valve if 2-3 seconds if ignition is not detected, you must look in the sight glass at the exact moment the Gas Control Valve icon appears on the display screen.

TESTING FOR IGNITION (FLAME):

- Set the Set Point Temperature high enough so there is a call for heat.
- Recycle the unit off and back on by turning the Enable/Disable switch to Disable for one second and then back to Enable.
- The unit will begin an ignition cycle.
- When the Gas Control Valve icon appears on display screen, immediately look through the sight glass for a brief blue flame (if you are getting an Ignition Failure error, the flame, if the burner ignites, will only be present for 2-3 seconds).

BURNER IGNITES (BRIEFLY)

- If the burner ignites briefly then shuts off with an "Ignition Failure" error message, follow these steps:
 - Remove the connector from flame sense rod [picture of connector showing location on unit]. Inspect the connector for corrosion. Replace if corroded or damaged. Remove Flame Sensor and clean metal end with steel wool.
 - Check insulator for soot, cracks or other damage and replace if necessary.

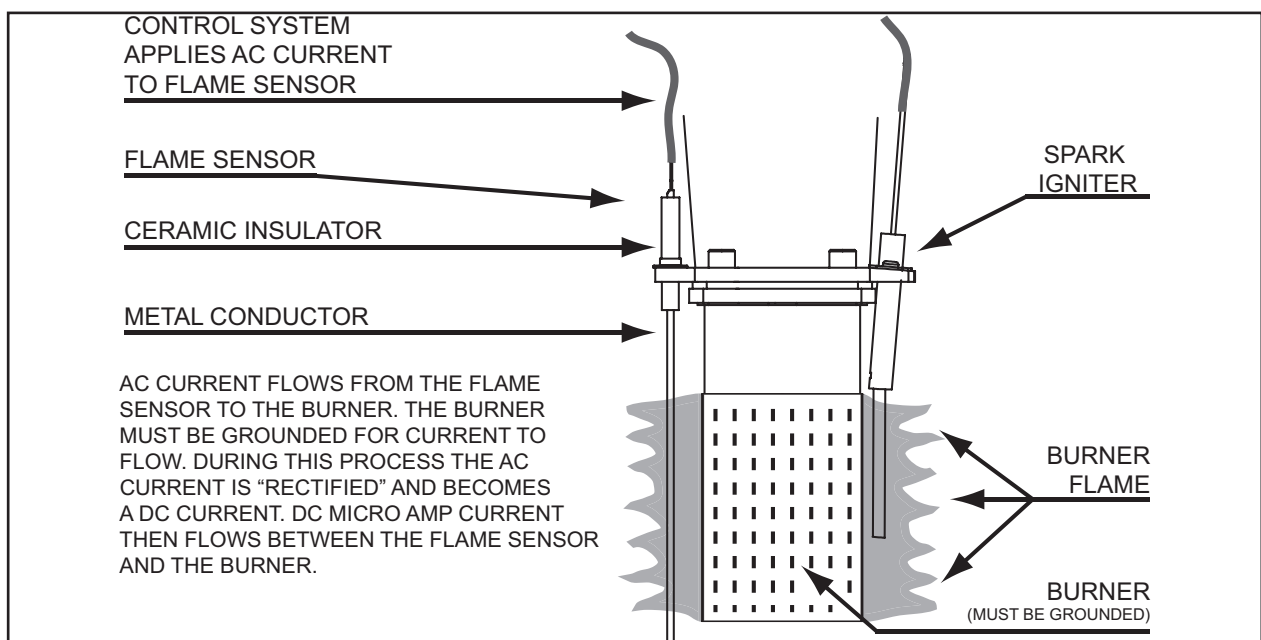

- Reinsert connector on Flame Sensor and make sure the electrical connection is clean and tight.
- Recycle unit again to start another ignition cycle. If the burner ignites but the flame sense rod still fails to detect flame, contact Commercial Technical Support.

BURNER DOES NOT IGNITE

Failure to ignite (no flame) usually means a gas supply or Gas Control Valve problem. If you do not see a brief blue flame through the sight glass during the ignition cycle (at the moment the Gas Control Valve icon appears on the display), follow these steps:

- Remove and reinsert the Gas Control Valve electrical connector. Make sure the electrical connections (pins) are clean and that the connector fits tightly.

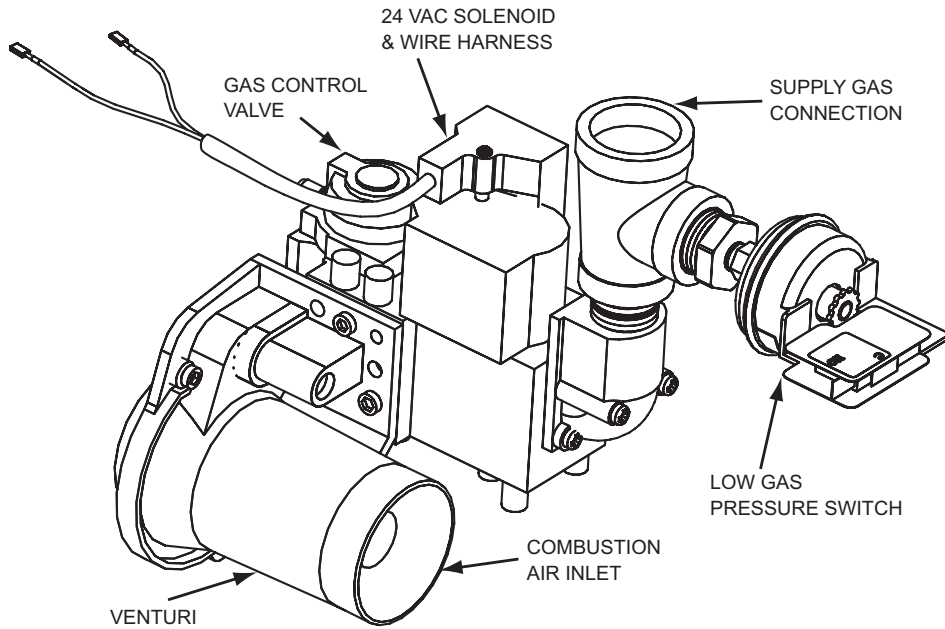

GAS CONTROL VALVE ASSEMBLY: SUF 60120 - 100250 MODELS

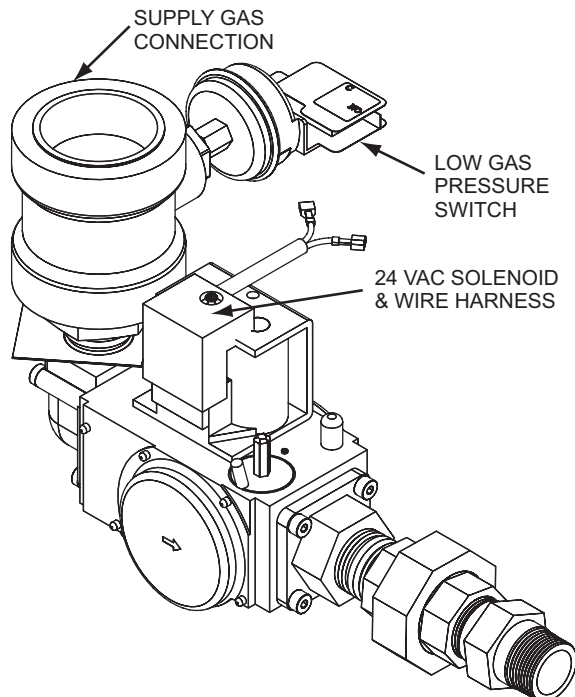

GAS CONTROL VALVE ASSEMBLY: SUF 119300 - 119500 MODELS

- Remove and reinsert the circuit board end of the Gas Control Valve connector. Make sure it is connected tightly and that the pins are clean.
- Recycle unit again to start another ignition cycle. If you still do not see a brief blue flame through the sight glass at the moment the Gas Control Valve icon appears on the display, verify that 24 VDC is present on the connector pins 1 and 5. Use care to not bend or damage the pins while testing.
- Connect test leads to the Gas Control Valve connector's pins. Gently connect probes to Gas Control Valve connector's two outer pins. Set the meter to DC volts.



- Recycle unit again to start an ignition cycle.
- At the moment the Gas Control Valve icon appears on the display, you should see 24 VDC on your meter. This electrical signal will only last for 2-3 seconds (if the burner does not ignite or the flame sensor does not detect ignition).

24 VDC PRESENT

- If 24 VDC is present on the Gas Control Valve connector during the beginning of an ignition cycle, reinstall the connector and recycle the unit again.
- Check the gas supply pressure during ignition using test procedure from "Gas Pressure Test" on Page 9.
- During the ignition cycle, the gas supply pressure should drop about 0.5" to 1.5" W.C. when the Gas Control Valve appears if the Gas Control Valve is working. If the gas supply pressure does not drop at the beginning of the ignition cycle, the Gas Control Valve may be defective—contact Commercial Technical Support. A pressure drop of more than 1.5" W.C indicates an issue with the gas supply (pipe too long or too small, bad regulator, etc.).

24 VDC NOT DETECTED

- If 24 VDC is not detected on the connector terminals when the Gas Control Valve icon appears on the display, contact Commercial Technical Support.

5. BLOCKED AIR INTAKE

Blocked Air Intake
Fault occurred 2 mins ago

 Restriction in air intake. Check intake pipe and termination for blockage.

Call a service professional:
Your Company Name Here
(press [DOWN] for more....)



[BACK](#) [ADVANCED](#)

CAUSES:

- The Blocked Air Intake Switch has detected a possible restriction in the air intake pipe.

CHECK/ REPAIR:

- Check pipe for restriction or excessive equivalent length.
- See Instruction Manual for pipe size, length and maximum number of elbows.
- Check actual pipe pressure with a manometer during blower operation. See "Pressure Switch Tests" section on Page 12 thru Page 15 under "Blower Operation Error" on Page 11.

6. BLOCKED EXHAUST

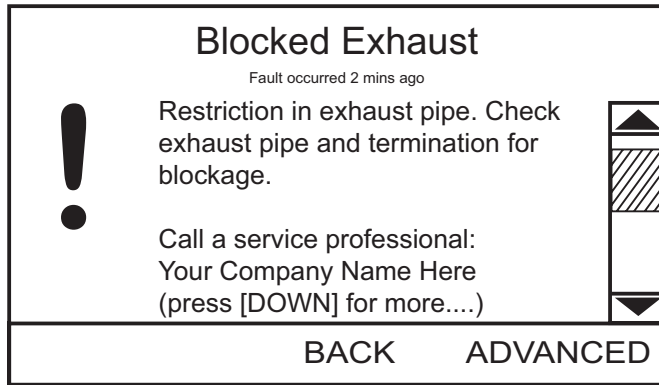

CAUSES:

- The Blocked Exhaust Switch has detected a possible restriction in the exhaust pipe.

CHECK/ REPAIR:

- Check pipe for restriction or excessive equivalent length.
- See Instruction Manual for pipe size, length and maximum number of elbows.
- Check actual pipe pressure with a manometer during blower operation. See "Pressure Switch Tests" section on Page 12 thru Page 15 under "Blower Operation Error" on Page 11.

7. FLAME SENSOR ERROR

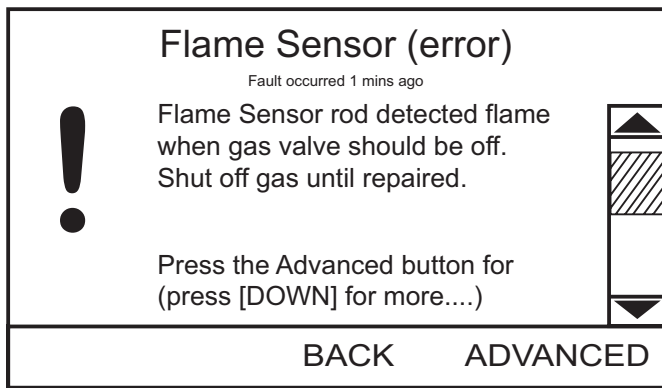

CAUSES:

- The Flame Sensor has detected flame when the Gas Control Valve is supposed to be off.

CHECK/ REPAIR:

- Look through sight glass. If flame is present, shut the main gas supply off. See Gas Control Valve section below to confirm proper operation.
- If flame is not present, cycle the unit Off by turning the Enable/Disable switch to Disable, wait for 5 seconds, and cycle the unit On by turning the Enable/Disable switch to Enable to see if the error clears. See "Flame Sensor" section on Page 24 thru Page 25.

GAS CONTROL VALVE

The 24 Volt Gas Control Valve on these water heaters is DC voltage valve. The CCB sends 24 VAC to the valve and the AC voltage is rectified into a DC voltage by electronics contained inside the plug end of the 24 Volt Gas Control valve wiring harness, see Figures below.

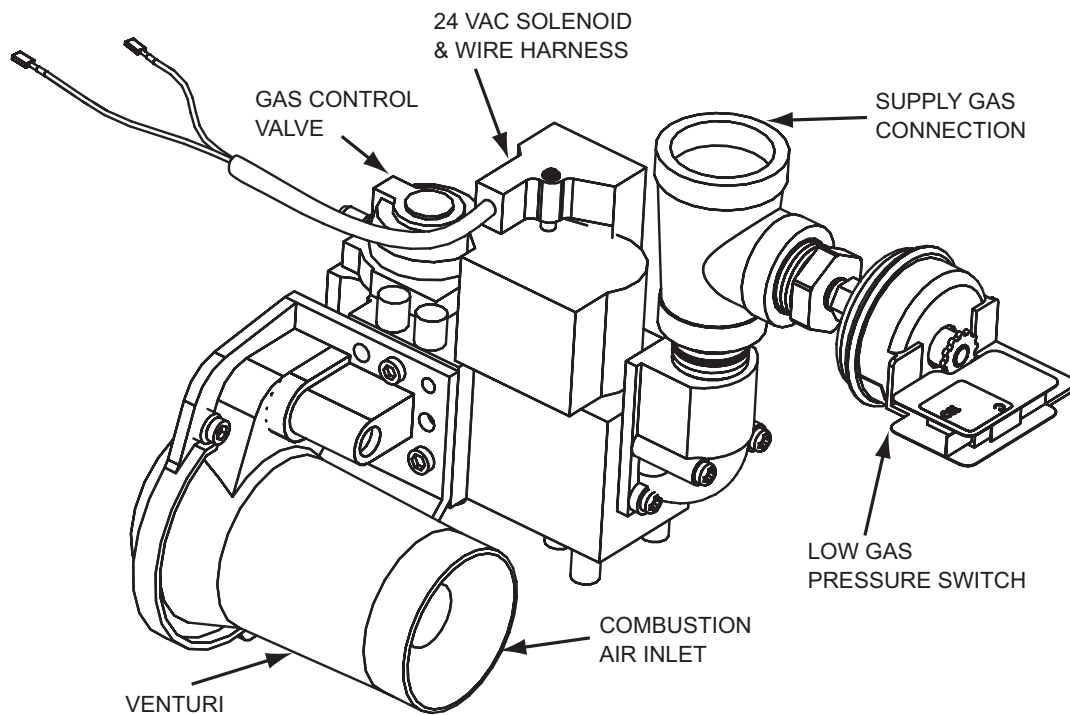

GAS CONTROL VALVE ASSEMBLY: SUF 60120 - 100250 MODELS

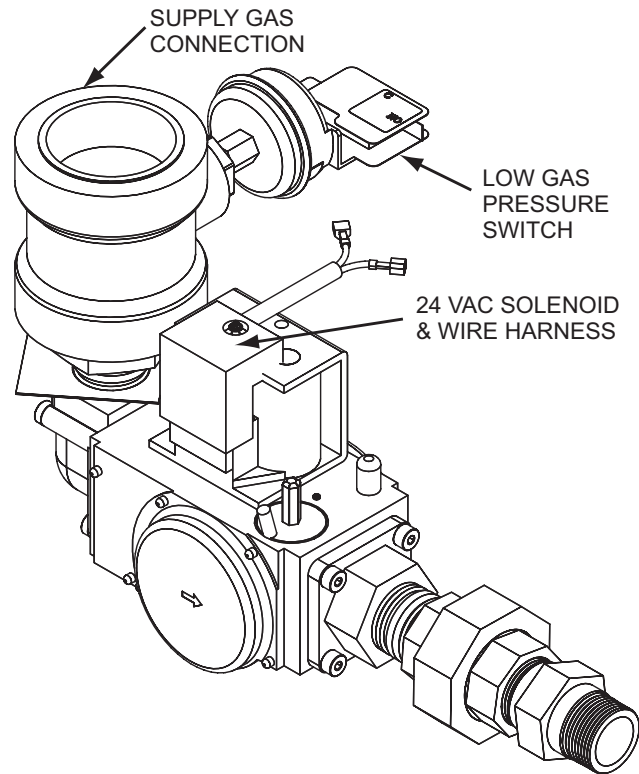

GAS CONTROL VALVE ASSEMBLY: SUF 119300 - 119500 MODELS

GAS CONTROL VALVE VOLTAGE TESTS

1. The animated Gas Control Valve Status Icon is displayed on the Control System UIM during these operating states. See "(UIM) User Interface Module Screen" Figure on Page 54. Check for 24 VAC supplied to the 24 Volt Gas Control Valve at pins 11 and 12 of the J14 Plug on the CCB, see "CCB Cover Removal And Replacement" on Page 48 and "CCB Circuit Board Layout" on Page 49. Using an "AC" volt meter insert the two test probes into pins 11 and 12 of the J14 Plug on the CCB during the Ignition Verification or Heating operating states, see Figure below. 24 VAC should be present. Note that the Gas Control Valve Voltage is only present for a short period of time during the ignition period.
2. Check for 24 VDC at the plug end of the 24 Volt Gas Control Valve wiring harness during the Ignition Verification operating state. Loosen the retaining screw for the 24 Volt Gas Control Valve wiring harness plug and disconnect the plug, see "Gas Control Valve" on Page 22. Lay the plug end upside down on a flat surface. Using an "DC" volt meter insert the two test probes into the two outside plug sockets, see Figure below. 24 VDC should be present.

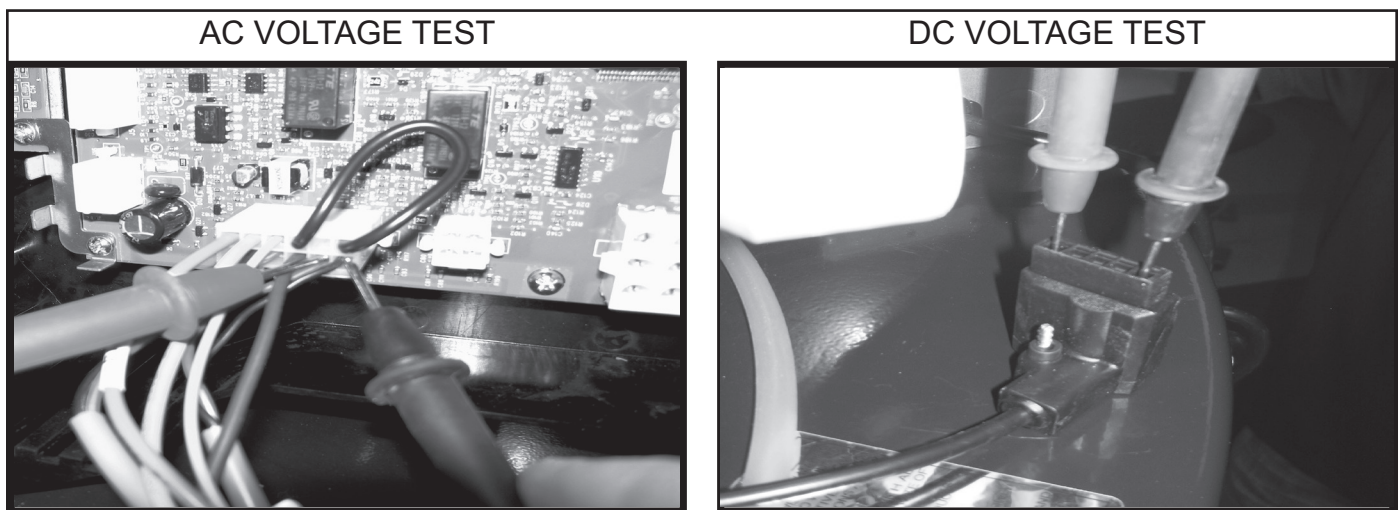

FLAME SENSOR

Ignition of the Burner is controlled electronically. The principle of operation for electronic ignition relies on flame sensing current to prove the fuel gas flowing to the Burner has been ignited.

Flame sensing requires an adequate earth ground to the water heater's Burner, see "Electrical Connections" on Page 35.

FLAME SENSING OPERATION

- The Flame Sensor is a metal (conductor) rod mounted in a ceramic insulator.
- The Control System applies an AC voltage to the Flame Sensor through a single wire.
- The burner flame will conduct a small amount of electrical current.
- The burner must be properly grounded for current to flow from the Flame Sensor to the Burner.
- During ignition the burner flame must make complete and continuous contact with the Flame Sensor.
- As the AC current flows from the Flame Sensor through the burner flame to the (grounded) Burner the AC current is "rectified" and becomes a DC current.
- The current flowing between the Flame Sensor and Burner is DC micro amp current expressed as: μA (micro Amps). Flame sensing current can be measured with a DC micro amp test meter, see "Tools Recommended" on Page 2.

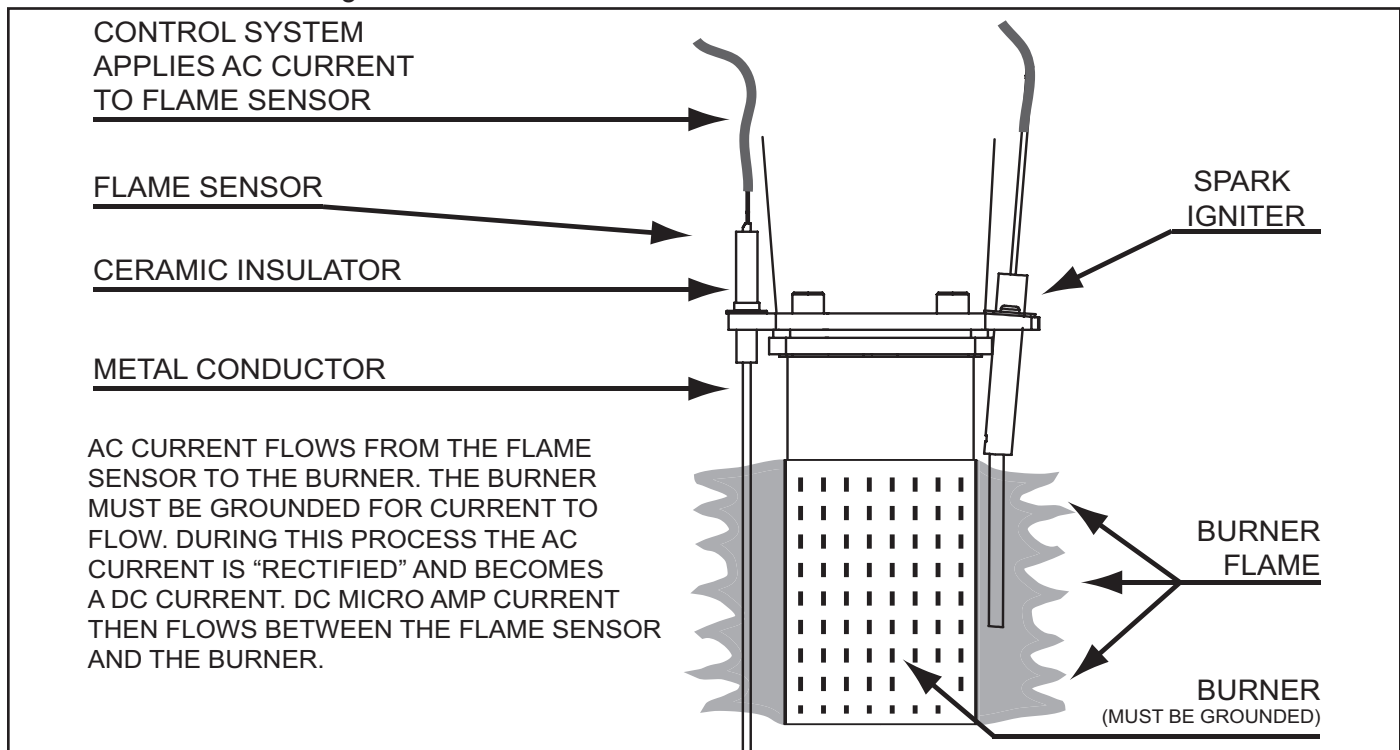

MINIMUM FLAME SENSING CURRENT

To prove burner flame during the Ignition Verification state the Control System monitors flame sensing current, the DC micro amp (μA) current flowing through the Flame Sensor. The Control System must sense a minimum amount of current to "prove" flame. The minimum flame sensing current is 1.0 μA . If flame sensing current does not reach 1.0 μA during ignition or falls below this amount during a heating cycle the Control System will immediately de-energize the 24 Volt Gas Control Valve.

After 3 failed trials for ignition the Control System will lock out and display **Ignition Failure** (fault condition) on the UIM. If flame sensing current drops below 1.0 μA during a heating cycle the Control System will de-energize the 24 Volt Gas Control Valve and enter the Inter-Purge operating state. After the Inter-Purge operating state the Control System will try for ignition again if a call for heat is still active, see the "Sequence Of Operation Flow Chart" on Page 6.

FLAME SENSING CURRENT TEST

During the heating cycle the flame sensing current is normally greater than 8.0 μA with a clean Flame Sensor. Over time the Flame Sensor can degrade and this will reduce flame sensing current. With heavier use, more heating cycles/greater load, this will occur more quickly.

Measuring flame sensing current requires a test meter with a DC micro amp function, see "Tools Recommended" on Page 2. The meter's selector is set to DC micro amps. The two test leads from the meter are placed in series with the flame sensing circuit. This can be done at the spade (male/female) flame sensing wiring connectors. See Figure below.

To measure flame current disable water heating by turning off the Enable/Disable Switch located in the front of the water heater and connect the test meter following the method shown in Figure below. Enable water heating and ensure a call for heat is active - when the Control System energizes the 24 Volt Gas Control Valve the meter will measure flame sensing current during normal operation.



Service Notes:

- The most common cause of **Ignition Failure** lock out is a worn Flame Sensor. The Flame Sensor should be inspected and cleaned anytime the measured flame sensing current is below 8 μA or the Burner has been removed. Clean the Flame Sensor with ultra fine steel wool. DO NOT use a coarse abrasive material such as sand paper. Inspect the ceramic insulator on the Flame Sensor for cracks, replace the Flame Sensor if it is damaged.
- An open flame sensing circuit caused by disconnected or loose connectors can also cause ignition failure. Check all wiring and wiring connections between the Flame Sensor and the J14 connector on CCB circuit board, see "CCB Circuit Board Layout" on Page 25.
- The Burner not being grounded will cause **Ignition Failure** - see "Electrical Connections" on Page 35. Ensure the water heater and the Burner are properly grounded.

8. NO WATER

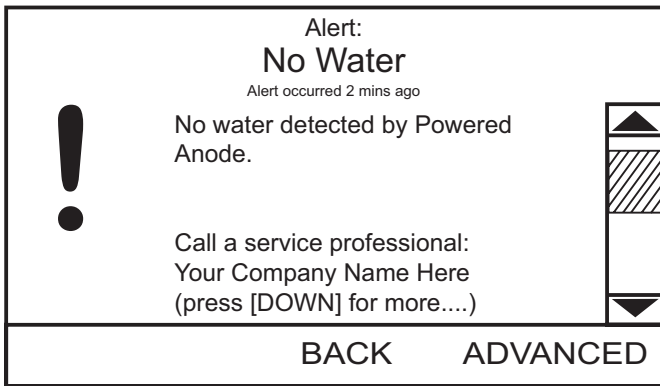

CAUSES:

- The controller has not detected a voltage potential of water in the tank.
- No water or low water in tank.
- Loose or open wiring connections to Power Anode(s).
- Power Anode shorted to ground at wire connection. See Powered Anodes section shown below.

CHECK/ REPAIR:

POWERED ANODES

The water heaters covered by this Service Handbook are equipped with powered anodes. SUF 60120 models only use 1 powered anode, all others will have two. These anodes do not need to be replaced unless damaged. The CCB monitors the current through the anodes and will declare a fault if there is a disconnected wire or if there is no water in the tank.

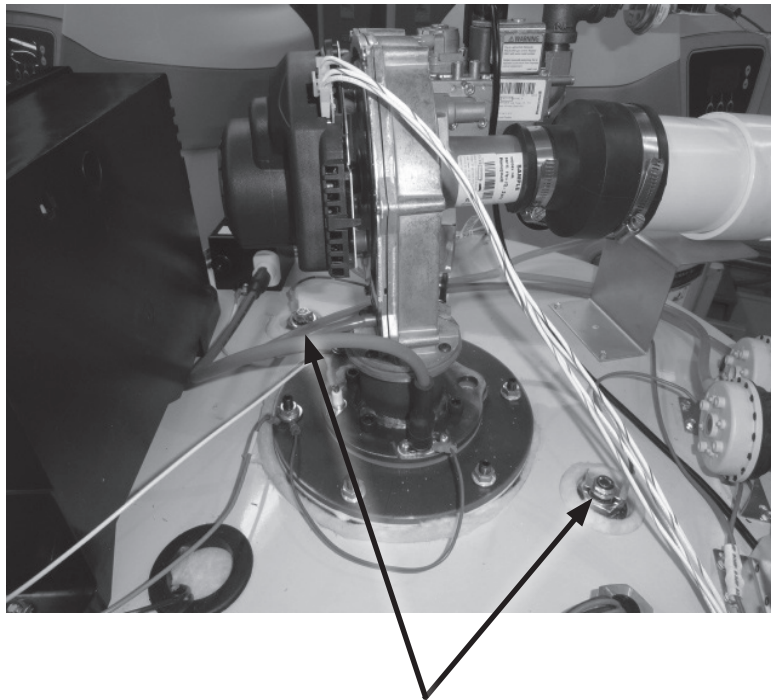

Powered Anode Connections

POWER ANODE CLEANING AND REMOVAL

1. Shut off gas, water and power supply going to the heater.
2. Relieve water pressure by either opening Temperature-pressure relief valve (T & P relief valve), if it is piped to a drain, or drain some water off by connecting a hose to the drain valve.

CLEANING METHOD:

If corrosion is present on the air side of the anode, use a wire brush to clean the outer nut and brass wire terminal tab. To clean the inner nut, remove the outer nut and the brass wire terminal tab. **DO NOT REMOVE** inner nut. Clean with wire brush. Reassemble and connect blue wire to brass terminal tab.

FRONT ANODE REPLACEMENT METHOD:

1. Remove blue wire from anode brass terminal.
2. Using a (1-1/16") socket remove the anode.
3. Use a round wire brush to clean the spud threads. If reusing the same anode, clean the bottom disc on the anode flange.
4. Apply Teflon tape pipe sealant to the new anode threads (as shown below), then insert anode and tighten securely.
5. Reconnect blue wire to anode brass terminal.
6. If necessary, bend brass terminal tab up to allow for socket tool to fit properly.



REAR ANODE REPLACEMENT METHOD:

1. Remove the two blower connectors from the blower; remove gas valve power plug and the two wires from the low gas pressure switch.
2. Remove air intake rubber boot from blower.
3. Disconnect gas supply connection from gas valve.
4. Remove the four (4) blower mounting screws to remove blower. Using a T-handle or hex head wrench usually provides adequate access.
5. Remove blower assembly with gas valve attached.
6. Repeat steps 1-6 from the Front Anode Replacement Method.

RE-ASSEMBLY:

1. Replace blower gas valve assembly; re-install the four (4) blower mounting screws.
2. Re-connect gas supply to the gas valve.
3. Re-install the air intake rubber boot to the blower.
4. Connect the two blower connector wires; connect the gas valve power supply plug and the two low gas pressure switch wires.
5. Turn on the water supply; be sure tank is filled with water.
6. Check the power anode voltage to measure the tank potential.
7. Turn on the gas and power supply.
8. Restart the heater.

9. ANODE SHORTED

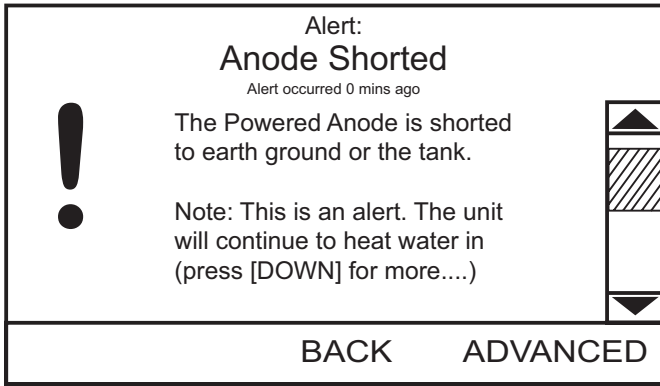

CAUSES:

- The controller has detected a low resistance or short to earth ground or the tank.

CHECK/ REPAIR:

- Bent anode shorting to tank.
- Contamination (solder, loctite, water, Etc.) between anode top and surrounding metal.
- Power anode shorted to ground at wire connection. See Powered Anodes section shown under "No Water" section on Page 26.

10. TEMPERATURE PROBE SHORT (UPPER OR LOWER)

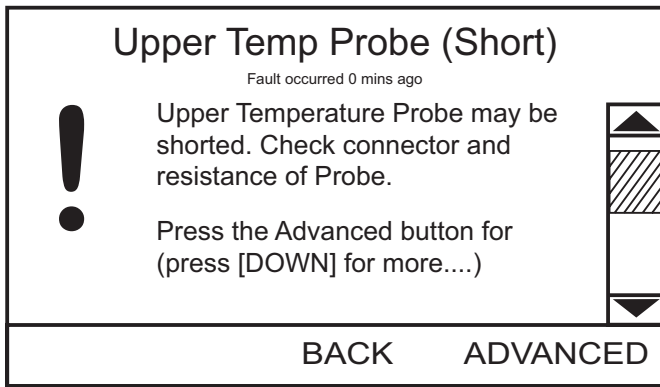

CAUSES:

- The Upper or Lower Temperature Probe appears to be shorted (very low resistance). This fault code often means the connector has been corroded by cleaning chemicals or other substances.

CHECK/ REPAIR:

- Make sure connector is clean and tight.
- Check probe's resistance.
- Replace the Temperature Probe if shorted (resistance is below 390 Ohms). See Temperature Probe section below.

TEMPERATURE PROBE

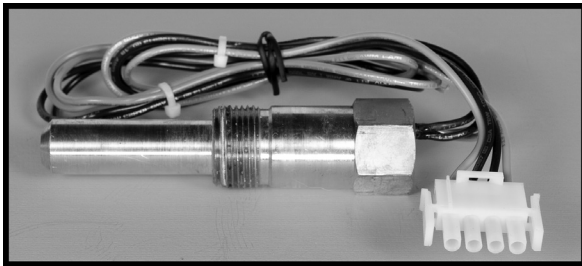

This section of the Service Handbook provides information on the Temperature Probe. The Temperature Probe contains the ECO (energy cut out) and a Temperature Sensor. The Temperature Probe connects to the J9 Socket on the CCB, see "CCB Circuit Board Layout" on Page 49 and "CCB Connection Identification" on Page 50.

ECO HIGH TEMPERATURE LIMIT SWITCH

The ECO (energy cut out) is a high temperature limit switch designed to protect against excessively high water temperatures inside the water heater's storage tank. The ECO is a normally closed switch that opens on a rise in temperature. The ECO switch is located inside the Temperature Probe (two red wires). The ECO temperature setting is non adjustable; the contacts open at 201°F (94°C) and will close at approximately 140°F (60°C).

The Control System constantly monitors the state of the ECO switch contacts. If the ECO activates (contacts open) due to abnormally high water temperature the Control System will lock out and display **Energy Cut Out (ECO)** on the UIM.

Should the ECO activate, the water temperature must drop below 140°F (60°C) before the Control System can be reset. Once the water temperature has cooled below this point the electrical circuit breaker that serves the water heater must be turned off and on again to reset the Control System.

TEMPERATURE SENSOR

The Temperature Sensor located inside the Temperature Probe is a "thermistor" (two black wires). Thermistors are thermally sensitive resistors. As the water temperature rises the resistance (measured in ohms) of the sensor will decrease; as the temperature falls the resistance will increase - see "Temperatures" Table on next page.

The Control System interprets changes in the temperature sensor resistance as changes in water temperature and uses this data to activate and deactivate heating cycles and displays this temperature in the Control System menus, see "(UIM) User Interface Module Screen" Figure on Page 54.

The Control System constantly monitors the Temperature Sensor. The Control System is programmed to declare a fault condition if the resistance of the temperature sensor drops below 390 ohms (shorted) or above 56,000 ohms (open).

If the resistance of the Temperature Sensor is below 390 ohms the Control System will lock out and display **Temp Probe Short** on the UIM. If the resistance of the temperature sensor is above 56,000 ohms the Control System will lock out and display **Temp Probe Open** on the UIM. The electrical circuit breaker that serves the water heater must be turned off and on again to reset the Control System. Note; the Control System will not reset unless the condition has been corrected.

TEMPERATURE SENSOR TEST

1. Turn off the circuit breaker that serves the water heater.
2. Remove the top cover on the water heater.
3. Disconnect the four pin plug/socket connection from the Temperature Probe outside the CCB enclosure in the middle, see Figures on next page.
4. Using an ohm meter: set the ohm meter range to a scale just above 30,000 ohms.
5. Check resistance between the two inside pins (black wires) of the plug end from the Temperature Probe, see Figures on next page. Compare the measured resistance to the values given in Temperatures Table below. Temperature Probes are very reliable and should only be replaced when:
 - The resistance is above 56,000 ohms (open) or below 390 ohms (shorted).
 - The nature of the service problem is temperature control and the resistance readings are considerably ($\pm 25\%$) different than the values in Temperatures Table below at the given temperature.

TEMPERATURES

WATER TEMPERATURE		TEMPERATURE SENSOR RESISTANCE IN OHMS
CELSIUS	FAHRENHEIT	
4°	40°	26,435
21°	70°	11,974
38°	100°	5,862
49°	120°	3,780
55°	130°	3,066
60°	140°	2,503
71°	160°	1,698
82°	180°	1,177

ECO CONTINUITY TEST

1. Turn off the circuit breaker that serves the water heater.
2. Remove the top cover on the water heater.
3. Disconnect the four pin plug from the Temperature Probe outside the CCB enclosure in the middle, see Figure on Page 31.
4. Ensure tank temperature is less than 100°F (38°C) - dump water to lower tank temperature if necessary.
5. Using an ohm meter set the range for continuity testing.
6. Check continuity between the two outside pins (red wires) of the plug end from the Temperature Probe, see Figure on Page 31.

Results/Actions

- If the ohm meter shows continuity (closed circuit) between the two outside pins (red wires) the ECO switch has reset properly. If the Control System continues to lock out displaying **Energy Cut Out (ECO)** on the UIM with continuity through the ECO present call the toll free support phone number listed on the back cover of this manual for further assistance.
- If the ohm meter shows no continuity (open circuit) between the two outside pins (red wires) and the tank temperature is known to be at or below 100°F (38°C) - replace the Temperature Probe. Follow the draining and filling instructions in the maintenance section of the Instruction Manual that came with the water heater when replacing the Temperature Probe.
- If the Control System continues to lock out displaying **Energy Cut Out (ECO)** on the UIM and the water temperature inside the water heater is becoming excessive (at or above 201°F/94°C) check water system piping; ensure heat is not being added by any other heating appliances or heat sources. If all these tests have been performed and the Control System continues to lock out call the toll free support phone number listed on the back cover of this manual for further assistance.

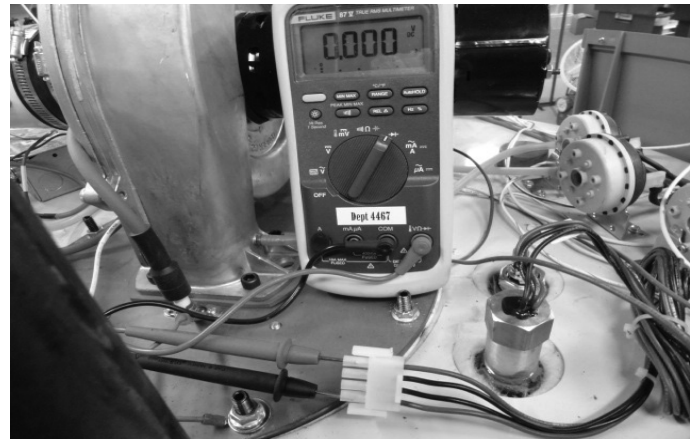

11. TEMPERATURE PROBE OPEN (UPPER OR LOWER)

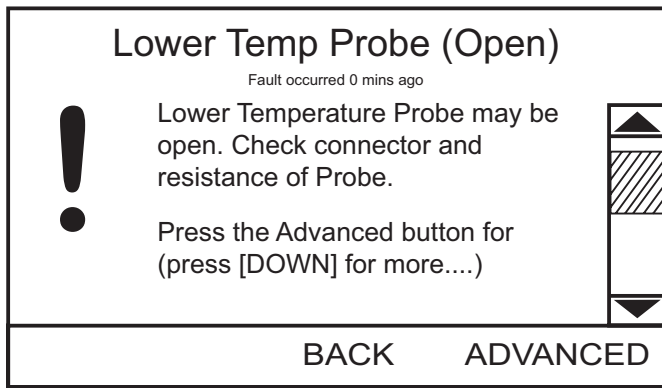

CAUSES:

- The Upper or Lower Temperature Probe appears to be open (very high resistance). This fault code often means the connector has been corroded by cleaning chemicals or other substances.

CHECK/ REPAIR:

- Make sure connector is clean and tight.
- Check probe's resistance.
- Replace the Temperature Probe if open (resistance exceeds 56,000 Ohms). See Temperature Probe section under "Temperature Probe Short (Upper or Lower)" section on Page 29.

VENTING

This section of the Service Handbook is not a complete venting installation instruction. Refer to the Instruction Manual that came with the water heater; ensure the venting has been installed per all Instruction Manual requirements. Costs to correct installation errors are not covered under the limited warranty.

GENERAL VENTING INFORMATION

The water heaters covered in this Service Handbook are operationally equivalent to Category IV appliances and may be installed in either a Power Vent or Direct Vent configuration.

Category IV Appliance

Category IV appliances operate with a positive vent (exhaust) static pressure and with vent gas temperatures low enough to produce condensate in the vent piping.

Power Vent Configuration

Power Vent configurations derive all combustion air from the room where they are installed and discharge all flue gases to the outdoor atmosphere through a sealed vent (exhaust) pipe. Power vent configurations have one vent pipe connected to the water heater which can be terminated in a vertical or horizontal arrangement.

Direct Vent Configuration

Direct Vent configurations derive all combustion air directly from the outdoor atmosphere through a sealed intake air pipe and discharge all flue gases to the outdoor atmosphere through a sealed vent (exhaust) pipe. Direct Vent configurations have two pipes connected to the water heater, one vent pipe and one intake air pipe. Direct Vent configurations can also be terminated in a vertical or horizontal arrangement.

PIPE SIZE REQUIREMENTS

Ensure the correct size pipe has been used for the length of intake air and/or vent piping installed. Refer to the Instruction Manual supplied with the water heater for the correct size and length of vent piping.

INTAKE AIR CONNECTION

The intake air connection has a screen and a hose barb installed at the factory, see Figure below.

The intake air connection screen is installed to prevent debris from entering the Combustion Blower and/or Burner. This screen is left in place when the water heater is installed in a Power Vent configuration but must be removed before connecting the intake air piping on Direct Vent installations. Once the intake air pipe is installed the screen, if not removed, would be hidden from view and may become clogged with debris over time. This can cause poor combustion and **Blocked Air Intake** fault conditions and Control System lock outs. Ensure this screen has been removed on all Direct Vent installations if experiencing **Blocked Air Intake** fault conditions.

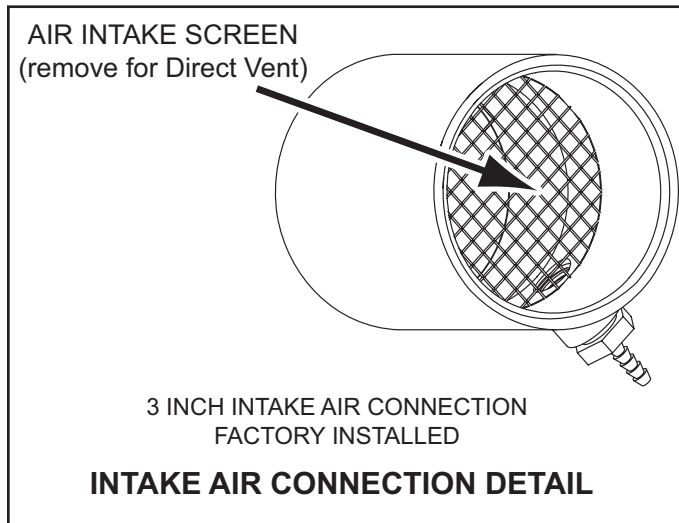

SUF 60120 - 100250 Models

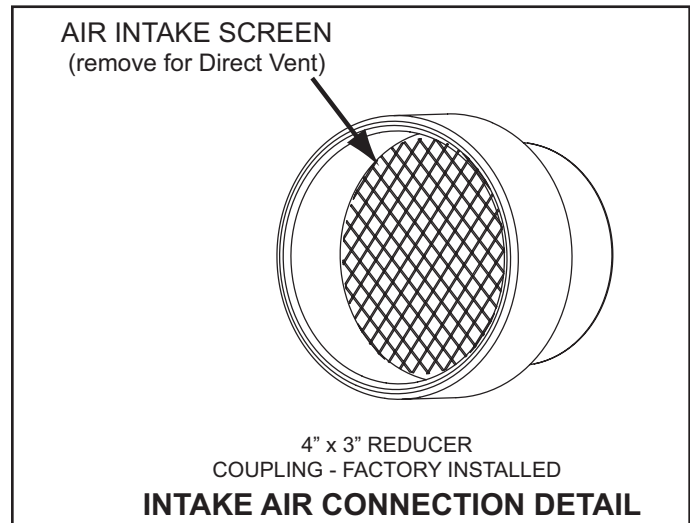

SUF 119300 - 119500 Models

AIR INTAKE SCREEN

Service Notes:

- Plastic debris left on the edges of intake air pipe sections after cutting must be removed on Direct Vent installations. This debris can collect inside and clog the Burner which can cause poor combustion, sooting, rough starting, rough operation and **Ignition Failure** fault conditions and Control System lock outs. The Burner is a radial design that can trap debris, see "Combustion Blower & Burner Assembly" section on Page 4.
- Exceeding the equivalent length limitations for the vent piping will cause **Blocked Exhaust** fault conditions and Control System lock outs.
- Exceeding the equivalent length limitations for the intake air piping will cause **Blocked Air Intake** fault conditions and Control System lock outs.
- Exceeding the maximum number of elbows allowed for the intake air and/or vent piping will also cause **Blocked Air Intake** and **Blocked Exhaust** fault conditions and Control System lock outs.
- Using smaller intake air and/or vent pipe than required for the installed equivalent length will also cause **Blocked Air Intake** and **Blocked Exhaust** fault conditions and Control System lock outs.

ELECTRICAL CONNECTIONS – ALL MODELS

The water heaters covered in this Service Handbook require a 120 VAC, 1Ø (single phase), 60Hz, 15 amp power supply and must also be electrically grounded in accordance with local codes or, in the absence of local codes, with the National Electrical Code, ANSI/NFPA 70 or the Canadian Electrical Code, CSA C22.1.

POWER FLUCTUATIONS AND ELECTRICAL NOISE

The water heater's control system requires a source of stable clean electricity for proper operation. Connecting the water heater to a branch circuit that is subject to fluctuations in voltage level or electrical line noise such as EMI (electro magnetic interference) or RFI (radio frequency interference) may cause erratic control system operation and malfunction.

A high quality power supply filter/suppressor must be installed if the above conditions exist. Call the technical support phone number listed on the back cover of this Service Handbook for more information.

Note: Malfunctions caused by power supply and costs to install power supply filters are not covered under the limited warranty.

DEDICATED POWER WIRING AND BREAKERS

Dedicated power supply wires, ground wiring and dedicated circuit breakers often reduce electrical line noise and are required when installing the water heater.

ELECTRICAL WIRING

All electrical work must be installed in accordance with the National Electrical Code, ANSI/NFPA 70 or the Canadian Electrical Code, CSA C22.1 and local requirements.

When installed, the water heater must be electrically grounded in accordance with local codes or, in the absence of local codes, with the National Electrical Code, ANSI/NFPA 70 or the Canadian Electrical Code, CSA C22.1.

If any of the original wire as supplied on the water heater must be replaced, it must be replaced with UL Listed Power Limited Circuit Cable of the same size and rating as original wiring.

POWER SUPPLY CONNECTIONS

The 120 VAC black (hot) wire from the power supply must connect to the black lead wire or the "L1" terminal block location in the junction box and the 120 VAC white (neutral) wire must connect to the white lead wire or the "Neutral" terminal block location in the junction box for correct polarity. See "Junction Box Assembly" Figure on next page.

Power supply connections must be made as follows:

1. Turn off the electrical circuit breaker that serves the water heater.
2. Remove the junction box cover.
3. Connect the 120 VAC black (hot) wire from the power supply to the black lead wire or the terminal block location marked "L1" inside of the junction box located on top of the water heater. If the black lead wire is used make the connection inside of the junction box with a properly sized wire nut. See "Junction Box Assembly" Figure on next page and "Wiring Diagrams" on Page 52 and Page 53.

Note: If electrical connection is made directly to terminal block remove black lead wire before making connection.

4. Connect the 120 VAC white (neutral) wire from the power supply to the white lead wire or the terminal block location marked "Neutral" inside of the junction box located on top of the water heater. If the white lead wire is used, make the connection inside of the junction box with a properly sized wire nut. See "Junction Box Assembly" Figure on next Page and "Wiring Diagrams" on Page 52 & Page 53.

Note: If electrical connection is made directly to terminal block remove white lead wire before making connection.

5. Connect the ground wire from the power supply to the grounding lug inside the junction box. See Junction Box Assembly Figure below and "Wiring Diagrams" on Page 52 & Page 53.

6. Replace junction box cover when connections are complete.

Note: Do not apply power to the water heater before installation is complete and the water heater is filled with water.

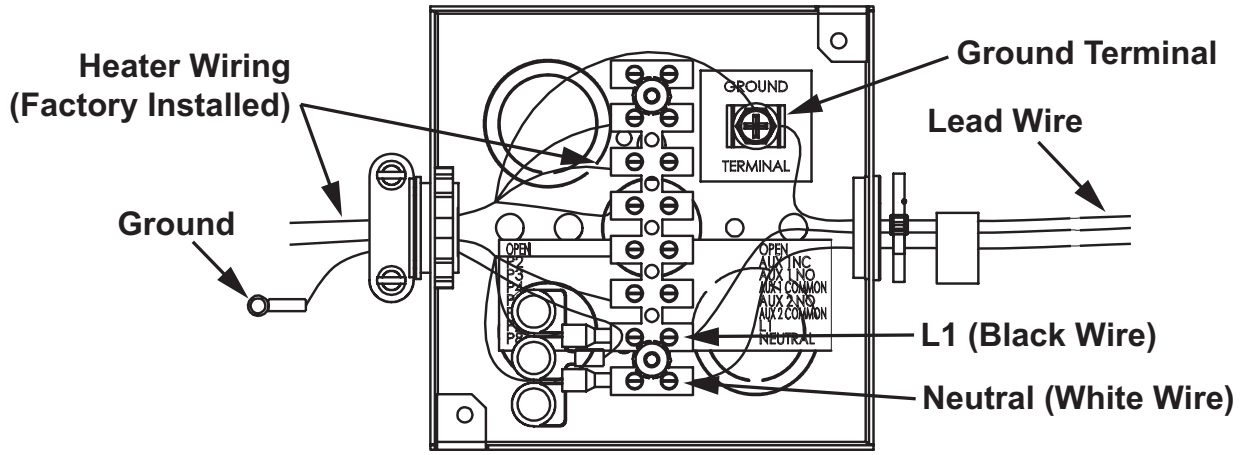

Junction Box Assembly

ENABLE/ DISABLE SWITCH

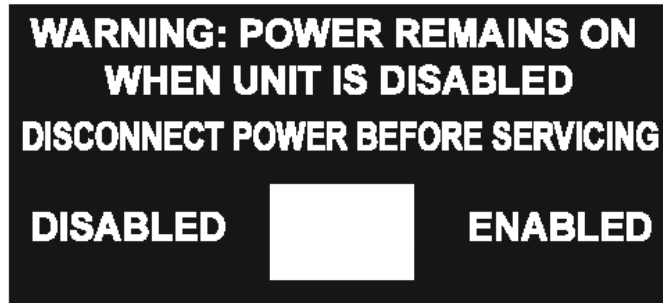

Enable/ Disable Switch

The Enable/Disable Switch is NOT an "on/off" switch and does not disconnect 120 volt power to the CCB and other heater components. When in the "Disabled" position the switch removes electrical power from the Gas Control Valve so that water heating is disabled. The display, CCB, and other electrical components will still be energized and the display will read "Water Heating Disabled". The Enable/Disable Switch can be used to disable operation and reset error codes. To operate the water heater, make sure the switch is set to "Enabled" position. Turn power off at the source (circuit breaker) during installation and servicing.

POWER SUPPLY TEST

Proper grounding and polarity can be verified with an AC volt meter by taking three voltage readings at the power supply wiring inside the water heater's 120 VAC junction box.

Check for AC voltage between:

1. Hot & Neutral - should be approximately 120 VAC.
2. Hot & Ground - should be approximately 120 VAC.
3. Neutral & Ground - should be approximately 0 VAC.

INSTALLATION CHECK LIST

The list below represents some of the most critical installation requirements that, when overlooked, often result in operational problems, down time and needless parts replacement. Before performing any troubleshooting procedures use the list below to check for installation errors. Costs to correct installation errors are not covered under the limited warranty. Ensure all installation requirements and instructions contained in the Instruction Manual that came with the water heater have been observed and followed.

See "Fault And Warning Codes" beginning on Page 7 for service procedures relating to the fault conditions mentioned below.

1. The vent (exhaust) pipe must not be combined or connected to any other appliance's vent system or chimney.
2. The intake air pipe must not be combined or connected to any other appliance's intake air piping.
3. The water heaters covered in this Service Handbook are condensing appliances. Condensate will form in the vent pipe during normal operation, condensate can also form in the intake air piping in certain circumstances. Ensure the intake air and/or vent piping is not installed in a manner that will allow water to be trapped in the piping. Install a condensate tee in the intake air and/or vent piping. Condensate trapped in the intake air and/or vent piping will lead to **Blocked Exhaust** and/or **Blocked Air Intake** fault conditions and Control System lock outs.
4. Ensure the intake air and/or vent piping is the correct size for the installed length. See the venting requirements section in the Instruction Manual that came with the water heater. Using smaller pipe than is required will lead to **Blocked Exhaust** and/or **Blocked Air Intake** fault conditions and Control System lock outs.
5. Ensure the intake air and/or vent piping are within the maximum equivalent lengths required in the Instruction Manual that came with the water heater. Exceeding the maximum length or number of elbows allowed will also lead to **Blocked Exhaust** and/or **Blocked Air Intake** fault conditions and Control System lock outs.
6. The metal condensate elbow supplied with the water heater has a built in water trap; thus it is not necessary to form another water trap. Condensate drain blockage will cause the exhaust elbow to fill with water and lead to **Blocked Exhaust** fault conditions and Control System lock outs.
7. Ensure the vent and intake air terminations have adequate clearances from each other and the terminations of other appliances. Failure to maintain adequate clearances can cause the recirculation of flue gases between the vent and intake air piping. Recirculation of flue gases will cause poor combustion, sooting, ignition failure, rough starts, rough operation, premature failure of the heat exchanger and icing of the combustion air intake during severe cold weather.
8. Direct vent terminations being installed in dead air spaces such as alleys, atriums, and inside corners can also cause the recirculation of flue gases between the vent and intake air piping. To prevent the recirculation of flue gases, maintain as much distance as possible between the intake air and vent terminations.
9. Ensure the screens in the factory supplied terminations are securely installed to prevent blockage in the intake air and/or vent piping.
10. On Direct Vent installations ensure the screen at the intake air connection on the water heater was removed before the intake air piping was connected, see "Intake Air Connection" on Page 34.
11. Ensure the water heater is properly grounded. The water heater Control System requires an adequate earth ground for flame sensing (verification), see "Flame Sensing Operation" on Page 24. Inadequate grounding to the water heater and/or the Burner will cause the **Ignition Failure** fault condition and Control System lock out. See "Electrical Connections" section on Page 35.

OPERATION AND SERVICE

HOW IT WORKS

This section of the Service Handbook will cover operation, common service procedures and water heater construction. The water heater covered in this Service Handbook has a helical shaped coil heat exchanger that is submerged in the storage tank. These water heaters use a top mounted down fired radial design Burner. This is a forced draft burner; hot burning gases are forced through the heat exchanger under pressure and exit through the exhaust/vent connection located at the bottom of the water heater.

Starting at the top air and fuel gas are drawn in by the Combustion Blower and Venturi. Flue gases and are forced through the helical shaped heat exchanger by the Combustion Blower and out through the exhaust/vent outlet.

COMBUSTION BLOWER

The Combustion Blower is an assembly that includes the blower housing, blower motor and an electronic speed control. The Combustion Blower is controlled by the CCB (Central Control Board) and is powered by a 3 pin wiring plug receiving 120 VAC from the Junction Box.

The CCB sends a signal from the J5 socket to a 5 pin wiring socket on the SUF 60120 - 100250 blower and VFD on the SUF 119300 - 119500 top cover control assembly. The signal is an electronic instruction to start, stop and control blower speed.

The Combustion Blower runs at higher speeds during the Pre/Post Purge operating states and runs at a lower speed during the Trial For Ignition operating state. The Igniter Status icon is displayed on the UIM during the Trial For Ignition operating state.

MODULATION

The water heaters covered by this Service Handbook are capable of modulating their firing rate. The CCB monitors the water temperature in the tank and regulates the firing rate to achieve the target temperature setpoint. The firing rate is dictated by the hot water draw, proximity to the tank temperature setpoint, and various other temperature limitations. Periodically, when the heater is in modulation mode, the CCB will increase the blower speed for a short period of time to clear out any condensation that may have accumulated in the heat exchanger then decreases the blower speed back to the modulating firing rate required to maintain the desired tank temperature setpoint. This ramping up and down of the blower speed is considered normal operation of the water heater.

Service Note:

The 5 pin PWM signal plug **MUST** remain plugged in to the 5 pin socket on the blower assembly at all times (SUF 60120 - 100250 Models only). Disconnecting this plug will cause the Combustion Blower to stop. If the electronic speed control is functioning properly Combustion Blower speed should noticeably reduce during the Trial For Ignition operating state. If blower speed reduction does not occur during the Trial For Ignition operating state ensure the 5 pin plug from the CCB is securely plugged into the matching 5 pin socket on the blower assembly and that the J5 plug is securely plugged into the J5 socket on the CCB circuit board. Perform a close visual inspection of the pins inside the plugs and sockets at the Combustion Blower and the CCB, replace any worn or damaged wiring harnesses as necessary.

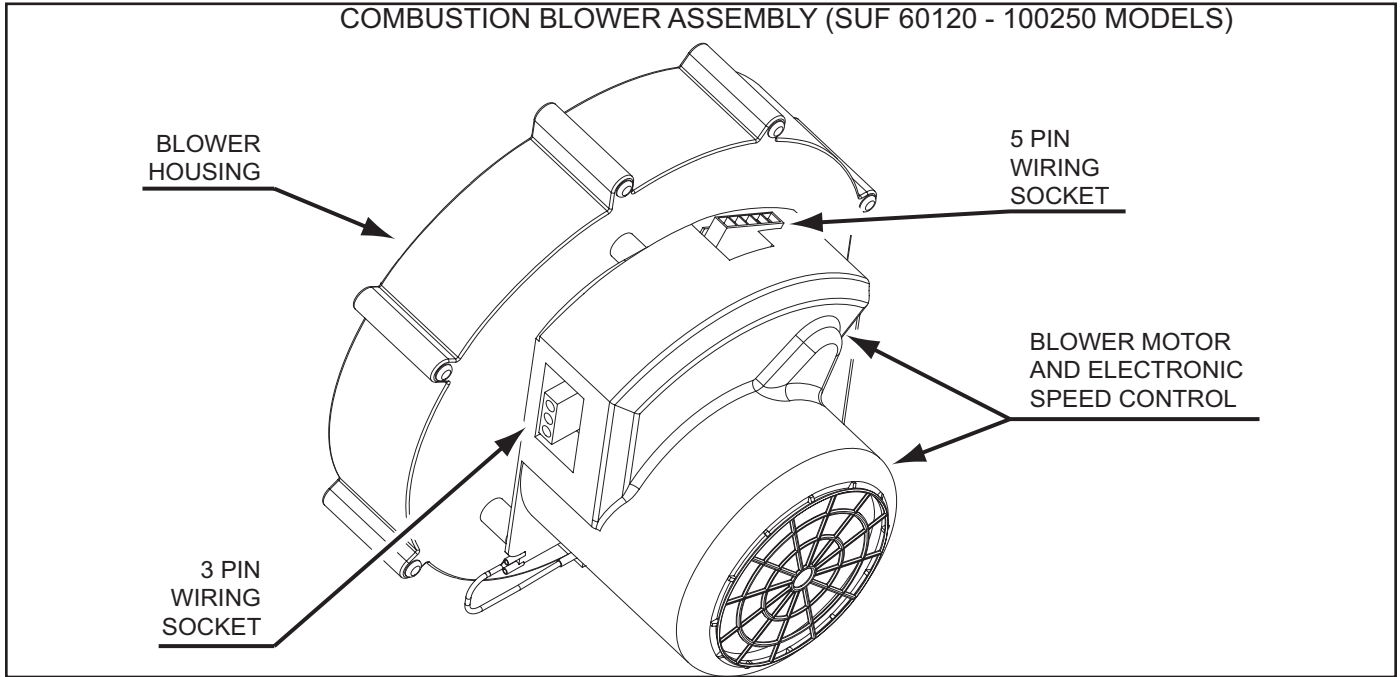

BLOWER SPEED CONTROL – SUF 119300 THRU 119500

The CCB monitors a feedback signal from a sensor that is installed on the blower. The CCB interprets the pulse signal from the sensor and then sends a signal to the variable frequency drive (VFD) which in turn transmits the proper frequency to the blower to produce the proper blower speed and input. Refer to the Variable Frequency Drive on next page for its operation.

Below is a chart for the blower rpms and corresponding VFD Hertz Readings for those rpms displayed on the VFD.

Note: These models are capable of modulating their input rate. Therefore, the RPM readings can be in between the Heating Speed and Minimum Modulation Speed RPMs. The input rate should be verified with the water heater operating at full input rate.

Model	Heating Speed RPM	Heating Speed VFD Hertz Reading	Minimum Modulation RPM	Minimum Modulation VFD Hertz Reading	Ignition Speed RPM	Ignition Speed VFD Hertz Reading
SUF 119300 Nat	3450	117.4	2350	79.7	4500	153.8
SUF 119300 LP	3200	108.8	2310	78.5	5770	198.2
SUF 119400 Nat	4625	158.3	2350	79.7	4500	153.8
SUF 119400 LP	4200	143.2	2310	78.5	5770	198.2
SUF 119500 Nat	5750	198.2	2350	79.7	4500	153.8
SUF 119500 LP	5225	179.8	2310	78.6	5770	198.2

VARIABLE FREQUENCY DRIVE – SUF 119300 THRU 119500

The SUF 119300 - 119500 models have a **variable frequency drive (VFD)** that controls the rpm of the blower motor. The VFD receives a signal from the central control board that instructs the VFD to transmit the proper frequency to the blower to produce the proper blower speed and proper input.

Three conditions must be met for the frequency drive to start the blower:

1. 120VAC must be supplied to the VFD 120VAC input.
2. The ignition control board closes an enable circuit – terminals LI1 and +24V
3. The ignition control board sends a 1-10VDC instruction – terminals 0V and AI1.

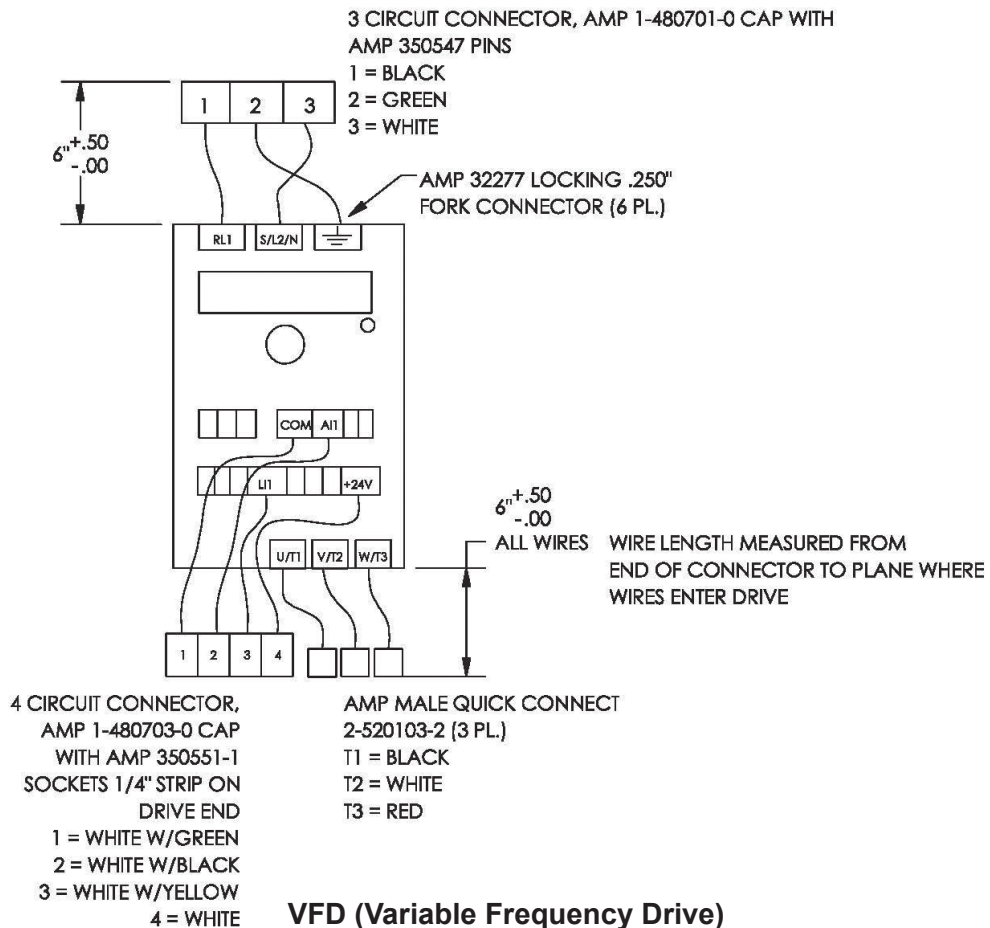
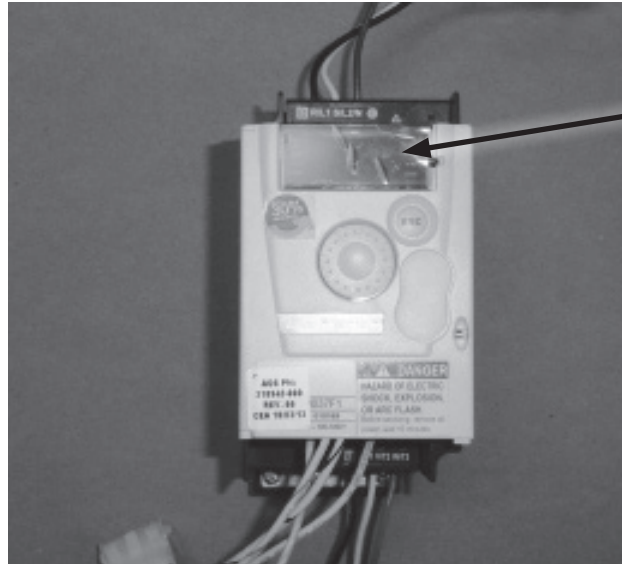

BURNER ASSEMBLY

The Burner is a radial design burner with a steel fiber jacket on the outer surface and is part of a larger Burner Assembly. Figures below show side views of the complete Burner Assembly removed from the water heater with key components identified. See the exploded view of the "Combustion Blower & Burner Assembly" section on Page 4 also.

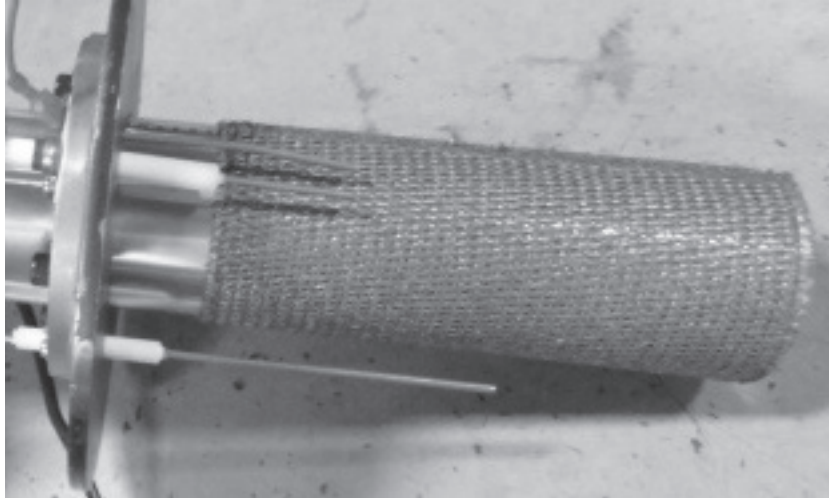

SUF 60120 - 100250 Models

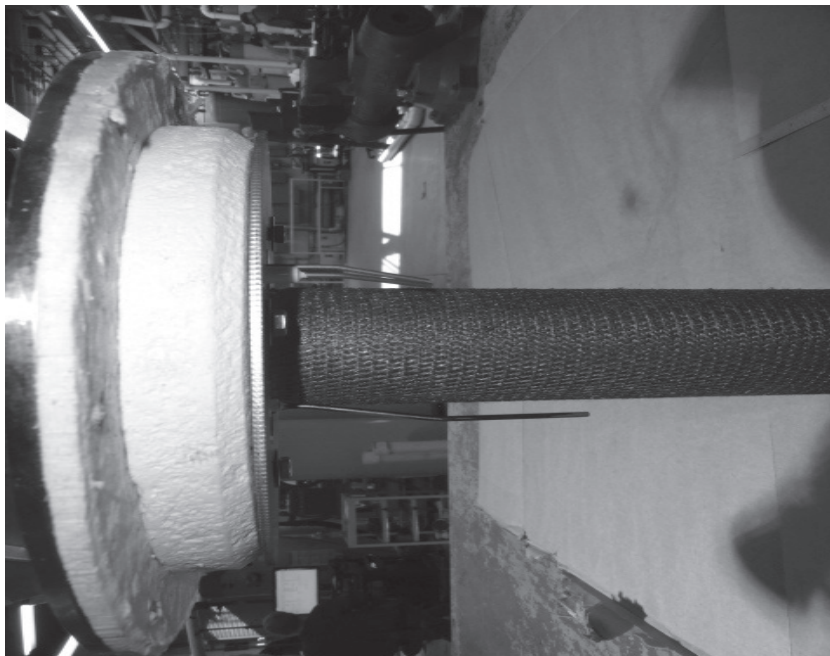

SUF 119300 - 119500 Models

COMBUSTION BLOWER AND BURNER REMOVAL/ INSTALLATION INSTRUCTIONS

Refer to the Combustion Blower & Burner Assembly, Heater Top View images in this Service Handbook and the Instruction Manual supplied with the heater for heater component locations.

COMBUSTION BLOWER/ BURNER REMOVAL

1. Turn the water heater's Enable/Disable switch to the "Disable" Position.
2. Turn off the electrical circuit breaker that serves the water heater.
3. Close the Main Gas Shut Off Valve serving the water heater.
4. Disconnect the supply gas line to the water heater on the heater side of the Main Gas Shut Off Valve.
5. If the water heater has been installed in a Direct Vent configuration, disconnect the Blocked Air Intake Switch sensing tube (light blue soft tubing) from the Air Intake Pipe Assembly and disconnect the intake air pipe at the intake air connection on the water heater by loosening the hose clamp closest to the Venturi and remove the Intake Air Assembly.
6. If the water heater has been installed in a Non-Direct Vent configuration, disconnect the Blocked Air Intake Switch sensing tube (light blue soft tubing) from the Air Intake Pipe Assembly and disconnect the intake air pipe at the intake air connection on the water heater by loosening the hose clamp closest to the Venturi and remove the Intake Air Assembly.
7. Unplug the ignition cable from the spark igniter and the yellow wire from the Flame Sensor.
8. SUF 60120 - 100250 Models: Disconnect the 3-Pin and 5-Pin plugs from the Combustion Blower Assembly. SUF 119300 - SUF 119500 Models: Disconnect the blower power wires at the three spade connectors connecting the blower to the VFD and unplug the blower speed feedback connector from the wiring harness.
9. Disconnect the 24 Volt power wires to the Gas Control Valve at the two spade connectors in the wiring harness to the valve.
10. Disconnect the Blower Prover Switch sensing tube (light blue soft tubing) from the Combustion Blower outlet sensing port.
11. Using a socket wrench with a 1/2" deep well socket remove the four (SUF 60120), six (SUF 100150 - 100250), or eight (SUF 119300 - 119500) 1/2" nuts from the studs holding the burner plate in place.
12. Slide the three burner ground wire eyelet connectors up and off of the studs.

Note: These ground wires must be reinstalled when reinstalling the Burner Assembly.

13. Ensure there are not any loose parts, tools, screws, or objects of any kind on top of the water heater before removing the Burner Assembly as these objects could fall into the heat exchanger.
14. Carefully lift the Burner Assembly straight up and out of the heater exchanger opening.
15. Refer to the Flame Sensor and Spark Igniter sections of this Service Handbook for their servicing specifications.

COMBUSTION BLOWER/ BURNER INSTALLATION

1. Install new white fiber Burner Plate (All Models) and Flue Ring (SUF 60120 - 100250 Models) before re-installing the Blower/Burner Assembly.
2. To re-install the Burner Assembly follow the steps for removal in reverse order.
3. Do not overtighten the 1/2" nuts.
4. Connect the supply gas line to the water heater on the heater side of the Main Gas Shut Off Valve.
5. Slowly open the Main Gas Shut Off Valve serving the water heater.
6. Turn on the electrical circuit breaker that serves the water heater.
7. Turn the water heater's Enable/Disable switch to the "Enable" Position.
8. Operate heater through at least one complete heating cycle to verify it is operating properly.

SPARK IGNITER

The water heaters covered in this Service Handbook use a Spark Igniter. The Spark Igniter has two rods: the sparking rod that has ceramic insulation and the grounding rod, see Figure below. During trial for ignition, the Control System powers a high voltage transformer (Ignition Control) from J6, and the Ignition Control supplies high voltage to the sparking rod via the ignition cable. The high voltage potential across the gap between the sparking rod and the grounding rod generate a spark.

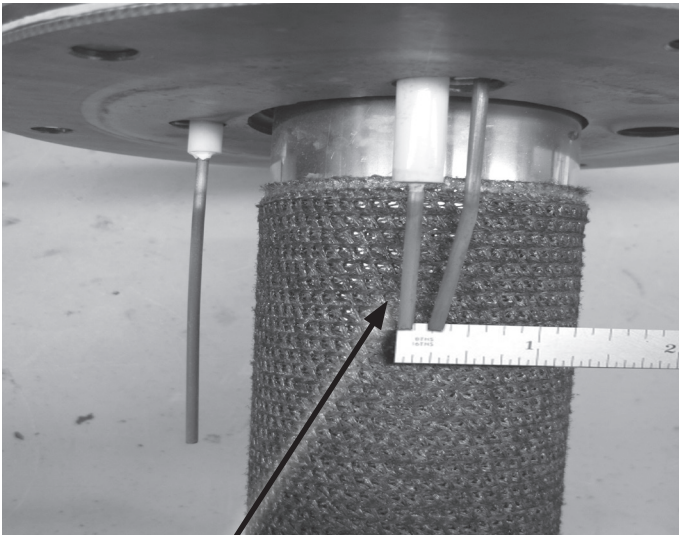

Spark Igniter (1/8"
Spark Gap)

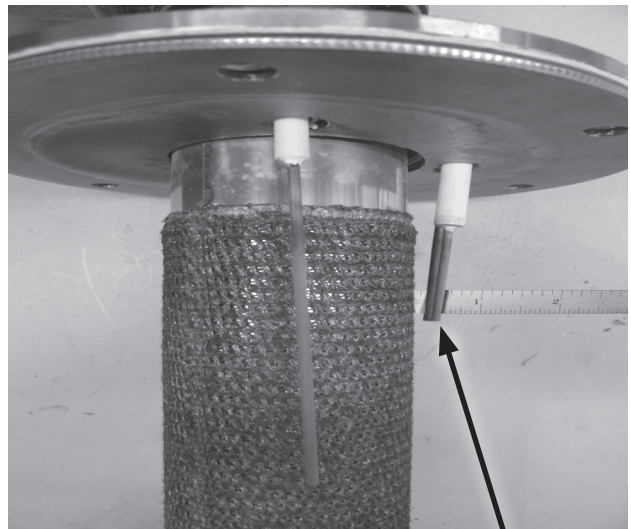

Spark Igniter
(5/16" Gap from
Burner)

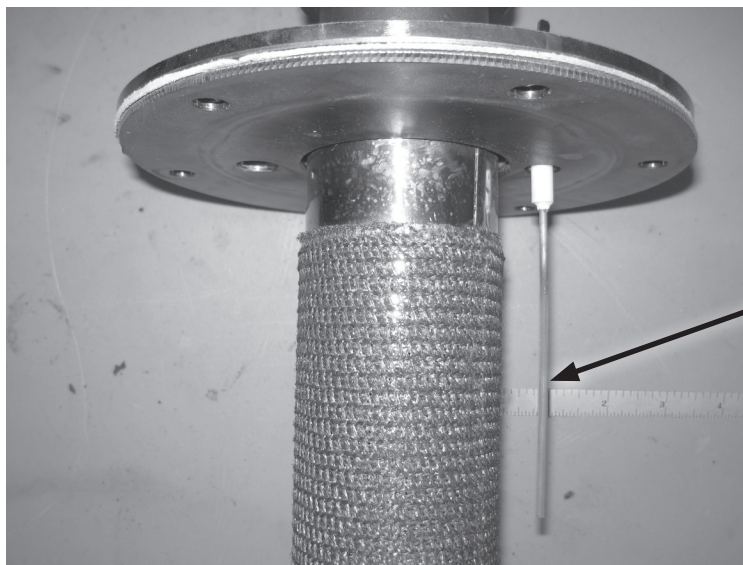

Flame Sensor
(1/2" Gap from
Burner)

SUF 60120 - 100250 Models

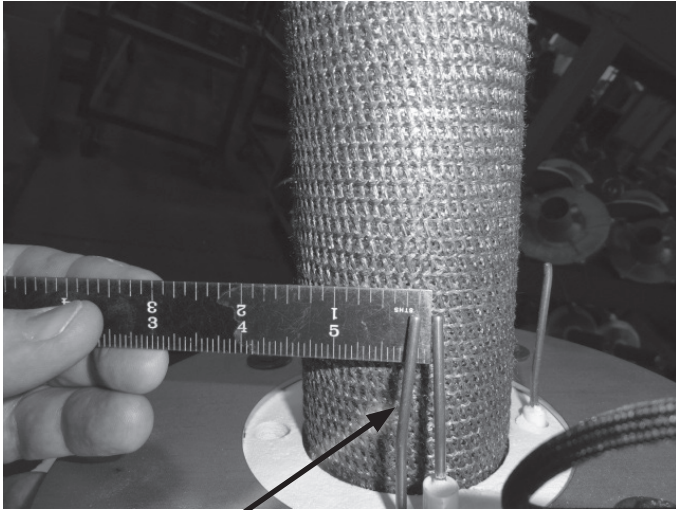

Spark Igniter (1/8" Spark Gap)

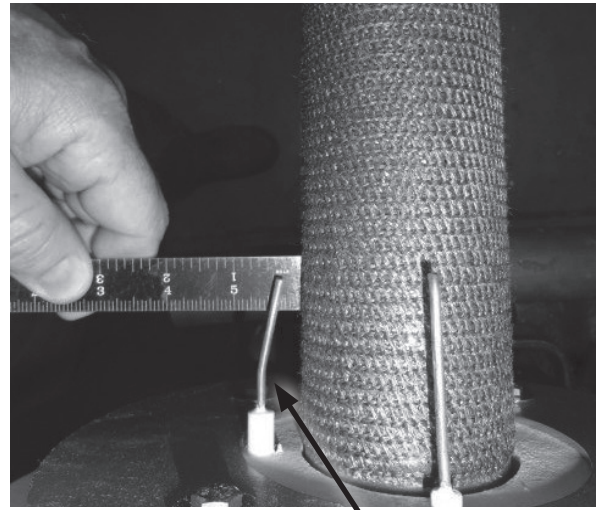

Spark Igniter (5/16" Gap from Burner)

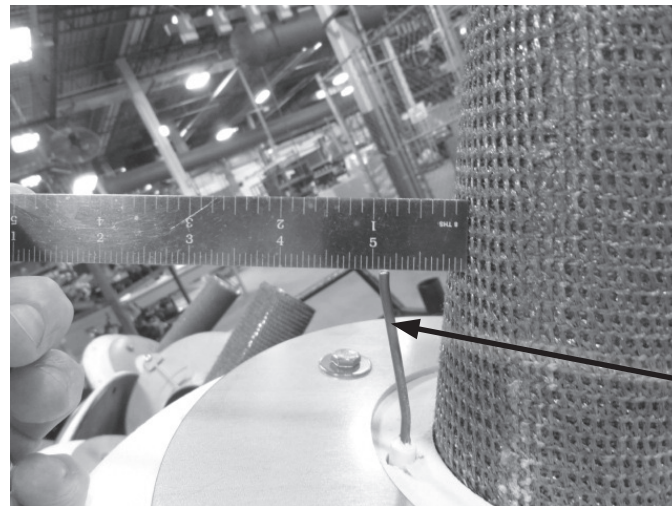

Flame Sensor (13/16" Gap from Burner at the tip of Sensor Rod)

SUF 119300 - 119500 Models

The Control System is programmed to start sparking a few seconds before the Gas Control Valve opens. See the "Sequence Of Operation Flow Chart" on Page 6.

Service Notes:

- The animated lighting bolt Status Icon is visible on the UIM. See "(UIM) User Interface Module Screen" Figure on Page 54.
- Ensure the wiring and connections between the J6 Socket on the CCB and the Burner Adapter are not broken, pinched or disconnected.
- Ensure there is approximately 120 VAC at the J6 Socket on the CCB.
- It is a good practice to check for any crack or damage to the ceramic insulator. If any crack is found, replace the Spark Igniter. Do not contaminate the ceramic insulator as this could make a shortage pass between the spark rod and grounding rod. Ensure good connection between the ignition cable and Spark Igniter.

GAS ORIFICE - SUF 119300 THRU 119500 MODELS

Refer to Orifice Chart below for correct gas orifice size. SUF 60120 thru 100250 Models and all Natural gas models do not use a gas orifice.

Without Orifice

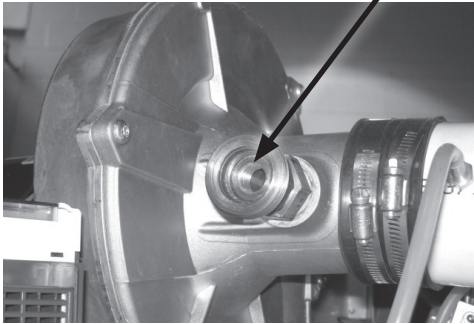

Gas Control Without Orifice Natural Gas

w/LP Gas Orifice

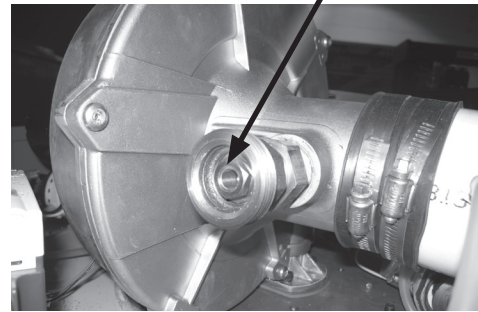

Gas Control With Orifice Propane (LP)

SUF 119300 - 119500 Models

ORIFICE CHART - SUF 119300 THRU 119500 MODELS

Models	119300	119400	119500
Natural	N/A	N/A	N/A
Propane (LP)	0.344"	0.344"	0.344"

CCB (CENTRAL CONTROL BOARD)

The CCB is a printed circuit board mounted inside a protective plastic enclosure, see Figures below and on next page. The CCB circuit board is the main control. All instructions for ignition and temperature control originate from this circuit board. Diagnostic and operational messages are generated by the CCB and sent to the UIM, see "(UIM) User Interface Module Screen" on Page 54.

Most of the water heater's components, such as the Spark Igniter, Combustion Blower, 24 Volt Gas Control Valve, and Temperature Probe are directly connected to one of the CCB's socket connectors.

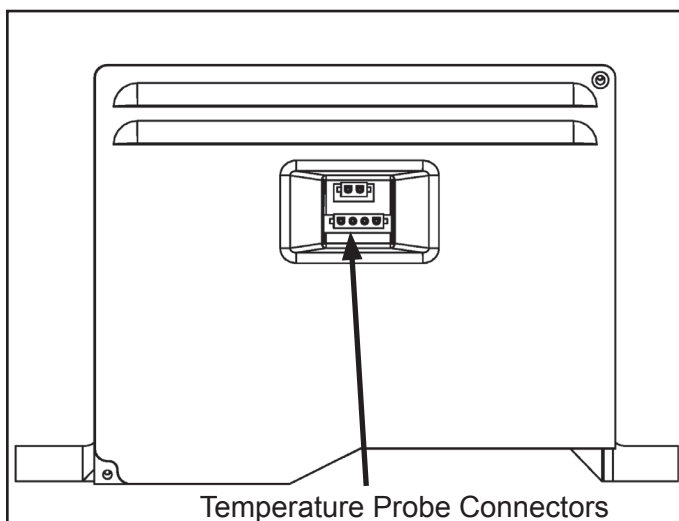
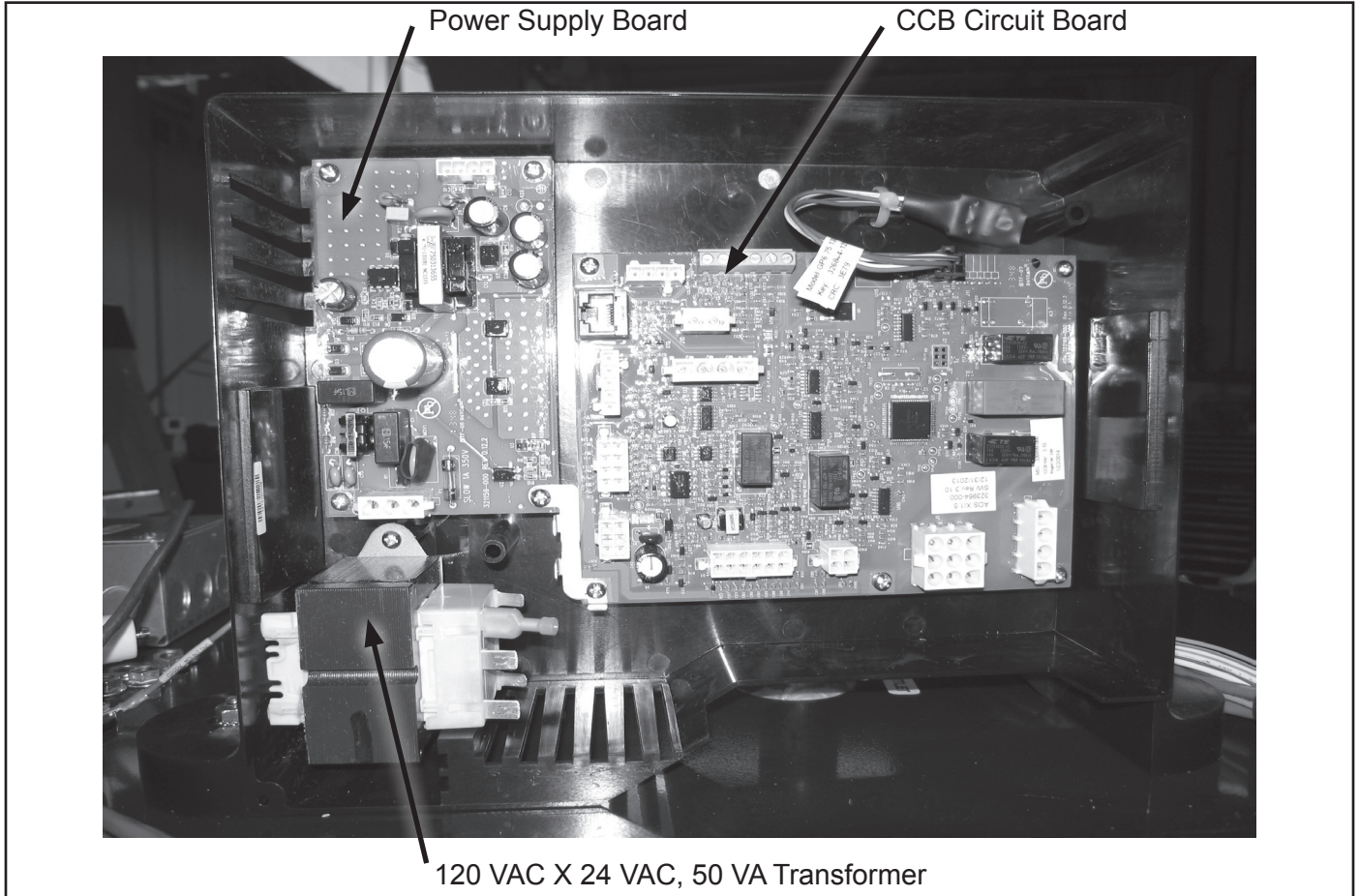

Front Cover On

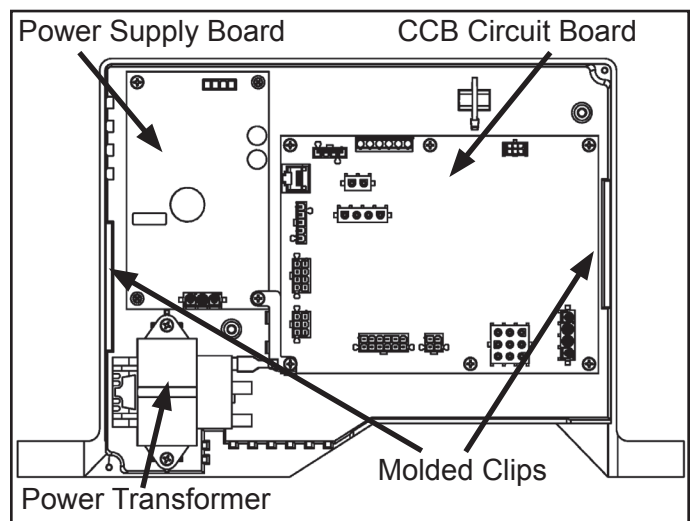

Front Cover Removed

CCB COVER REMOVAL AND REPLACEMENT

The cover on the CCB enclosure must be removed for various service procedures outlined in this Service Handbook. Refer to the instructions below when removing and replacing the CCB cover.

Wiring to and from the CCB and other water heater components enters the CCB enclosure on the bottom.

Removing the enclosure cover is a simple procedure. Care must be taken when replacing the CCB cover to ensure the wiring is routed properly and the cover is replaced correctly. Follow the procedures below to ensure the wiring is not pinched or damaged and no connectors are accidentally unplugged.

Cover Removal Procedure:

Refer to "CCB" section on Page 47 for these instructions.

1. Ensure power to the water heater is turned off.
2. Remove the upper and lower temperature probe connectors.
3. Unlock clips on both sides and remove the cover.

Cover Replacement Procedure:

1. Follow Cover Removal Procedure in reverse order to replace cover.

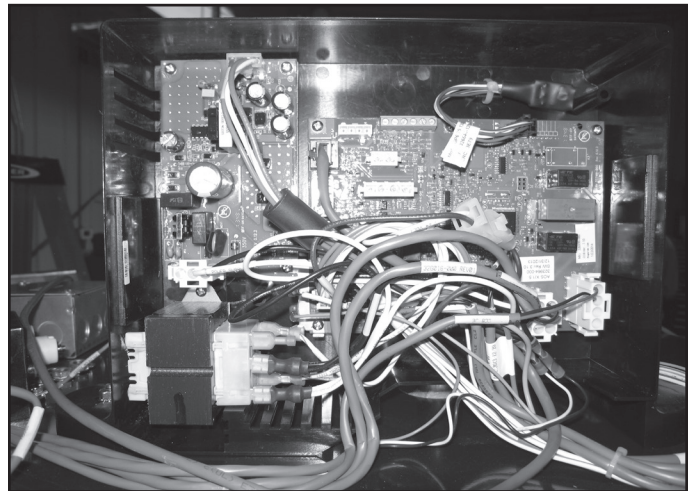
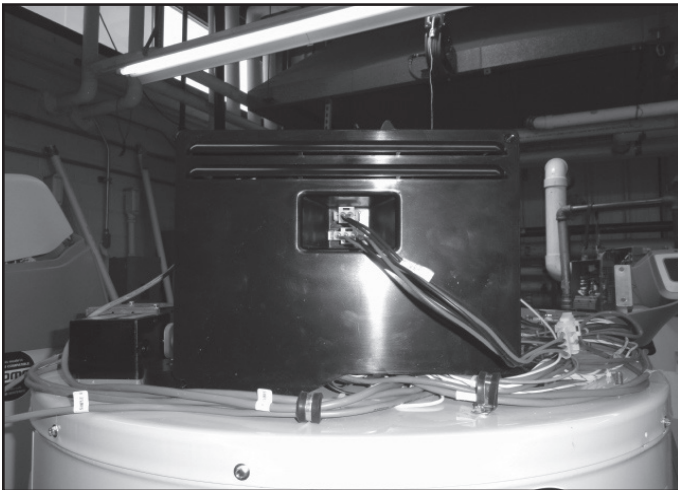

Service Notes:

If any operational problems, fault conditions or Control System lock outs occur after the CCB enclosure cover has been removed and replaced, remove the cover again to ensure none of the wiring connectors are unplugged and/or any of the wiring has been pinched, cut or damaged. Unlike previous water heaters in this product line, the individual control boards inside the plastic enclosure are serviceable parts. See the Parts List that was shipped with the water heater for the appropriate part numbers for each component.

CCB CIRCUIT BOARD LAYOUT

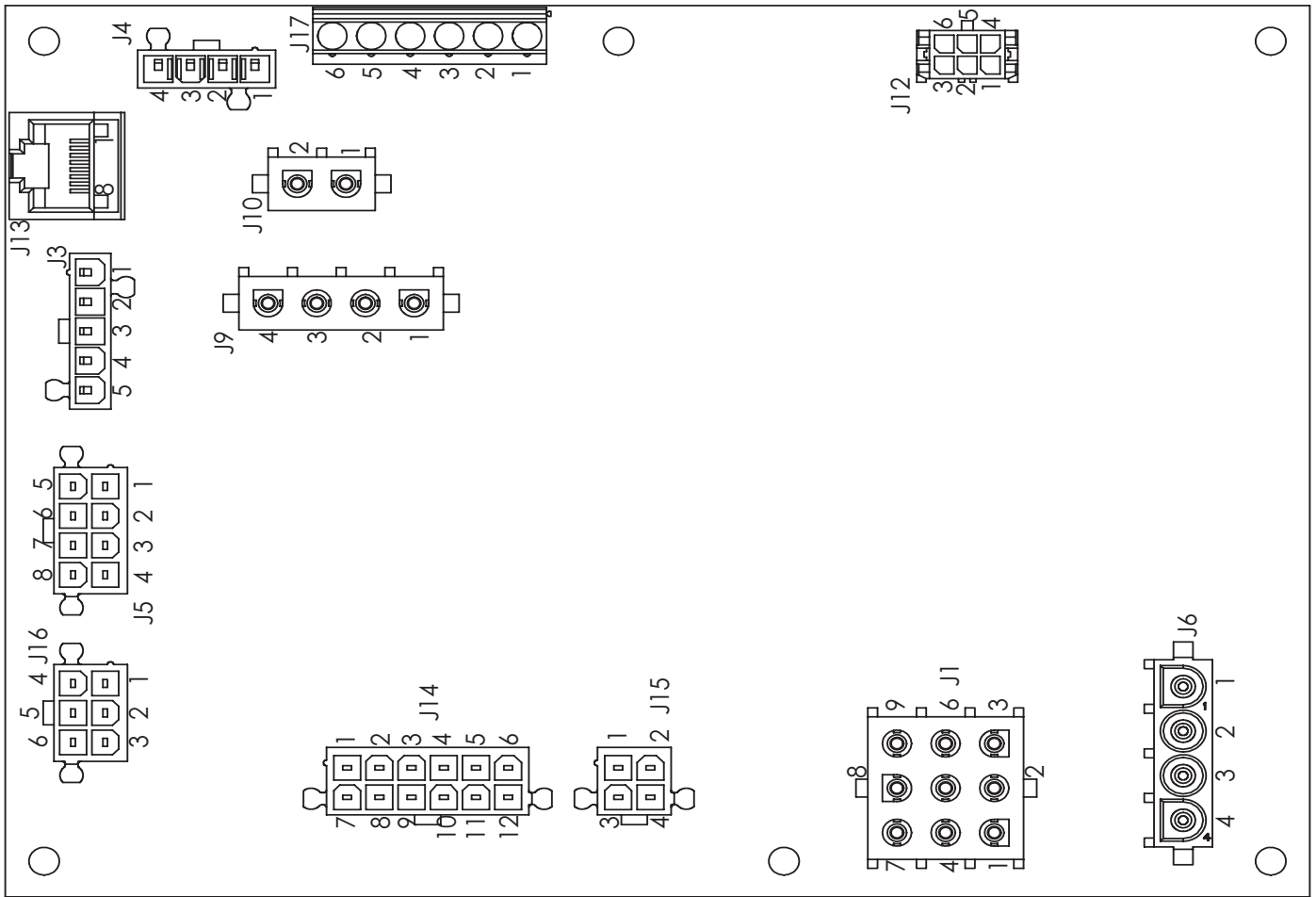

CCB (CENTRAL CONTROL BOARD)

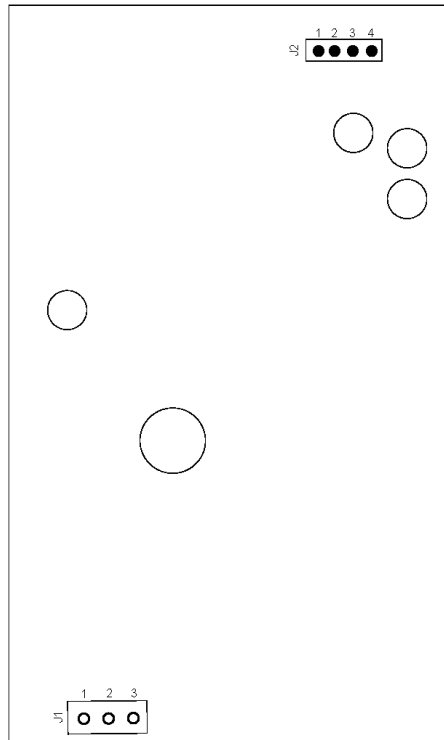

POWER BOARD ASSEMBLY

CCB CONNECTION IDENTIFICATION

J1 Socket - High Voltage In

PIN #	DESCRIPTION
1	Ground
2	AUX NC
3	AUX NO
4	AUX Common
5	Not Used
6	AUX NO
7	AUX Common
8	Line Voltage
9	Neutral

J5 Socket - Blower Logic (VFD/ Blower)

PIN #	DESCRIPTION
1	24V
2	PWM Signal
3	Not used
4	Blower Speed Feedback
5	Grounding

J6 Socket - 120V Out

PIN #	DESCRIPTION
1	Neutral
2	Line Voltage Out

J9 Socket - Temperature Probe

PIN #	DESCRIPTION
1	ECO
2	Thermistor
3	Thermistor
4	ECO

J12 Socket - Configuration Key

J13 Socket - Display/ AIN

J14 Socket - Limit String

PIN #	DESCRIPTION
1	Anode
2	Grounding
3	Flame Sensor
4	Condensate
5	Not Used
6	Condensate
7	Gas Pressure Switch
8	Gas Pressure Switch
9	Gas Control Valve
10	Gas Control Valve
11	24V
12	24V Return

J15 Socket - Pressure Switches

PIN #	DESCRIPTION
1	Blower Prover Pressure Switch / Blocked Air Intake Pressure Switch
2	Blocked Air Intake Pressure Switch / Blocked Exhaust Pressure Switch
3	Blower Prover Pressure Switch
4	Blocked Exhaust Pressure Switch

J16 Socket - Low Voltage In

PIN #	DESCRIPTION
1	24V AC
2	24V AC
3	Not Used
4	12V DC
5	5V DC
6	Grounding

WIRING DIAGRAM – SUF 60120 THRU 100250

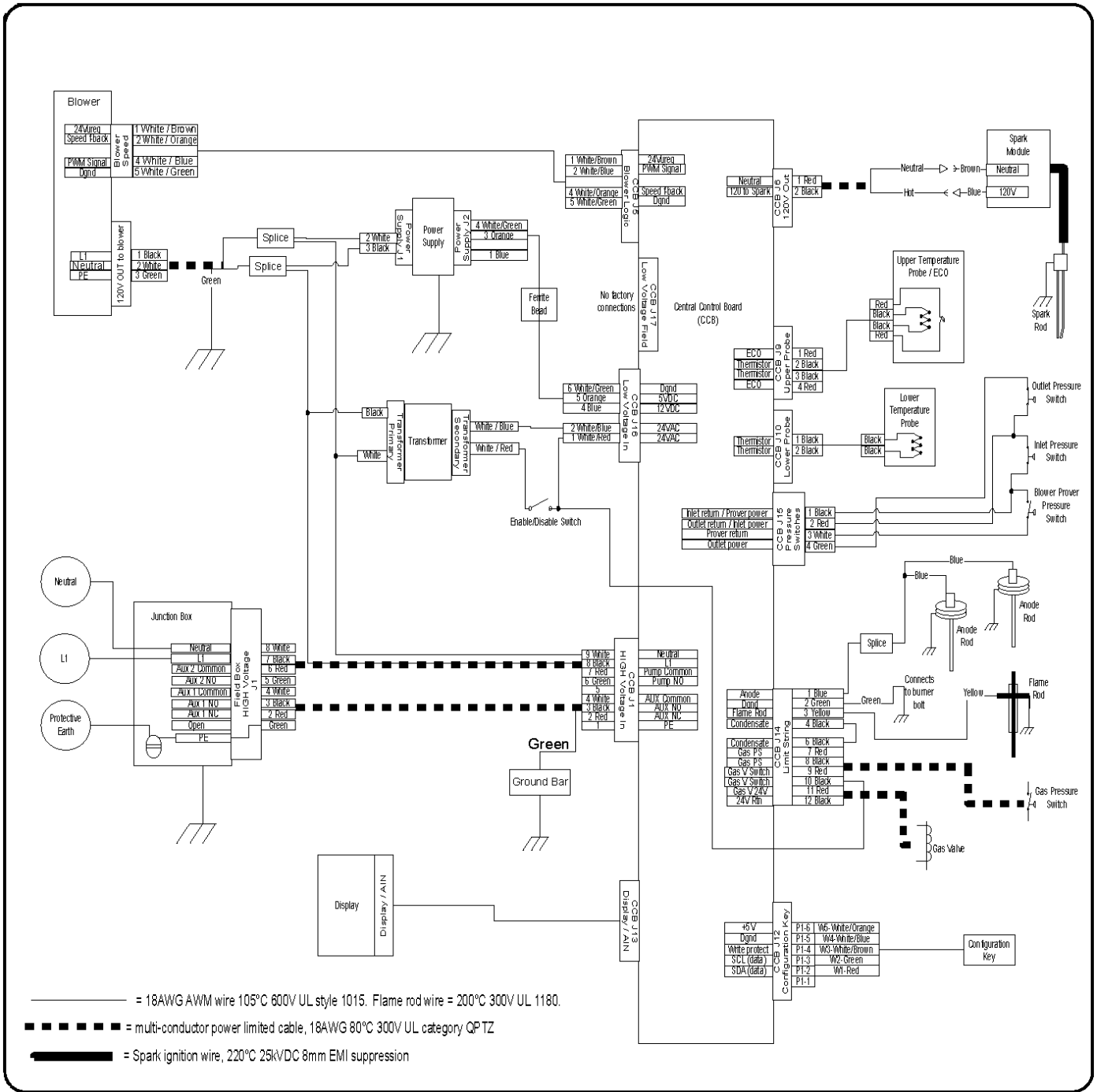

WIRING DIAGRAM – SUF 119300 THRU 119500

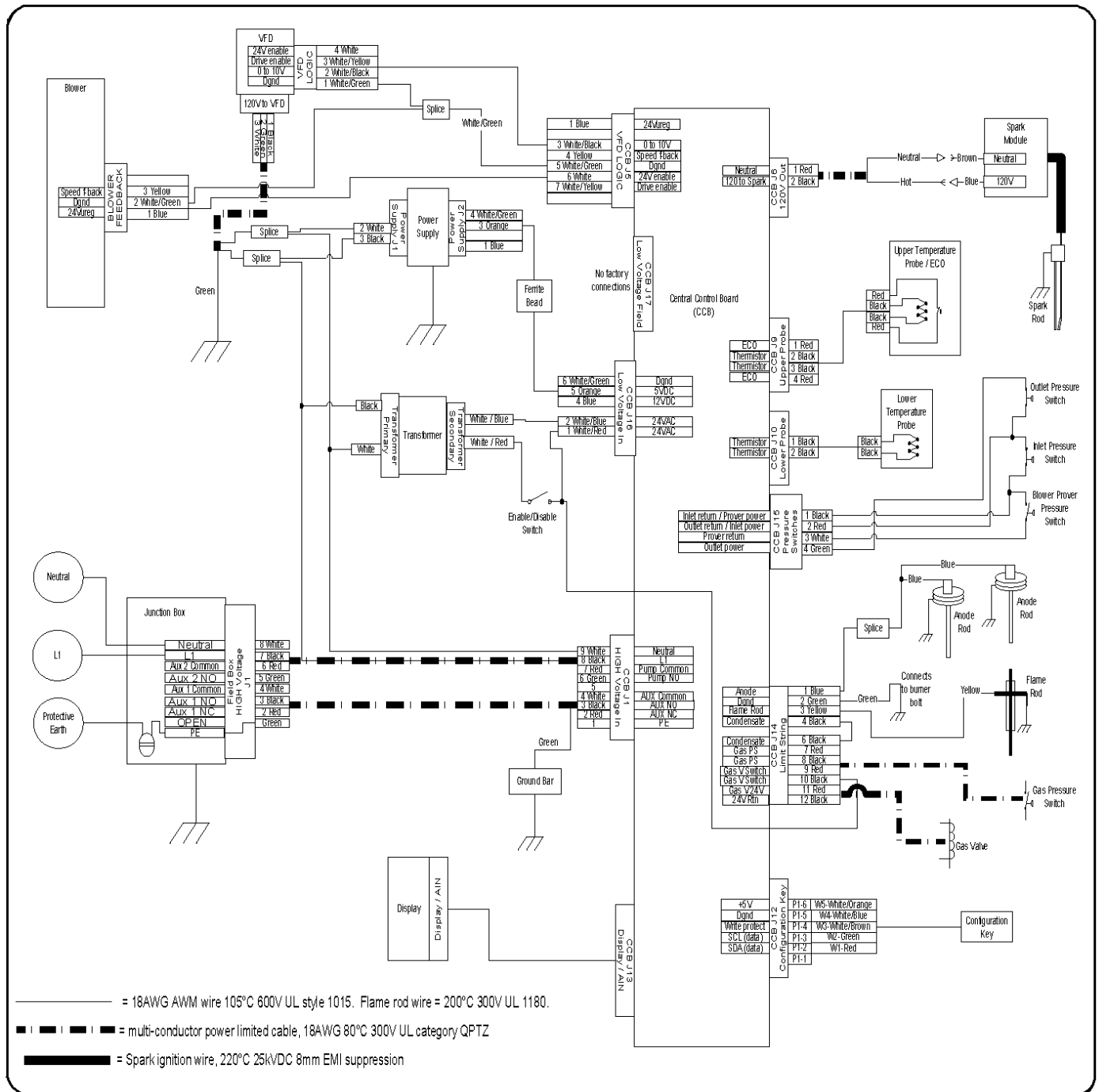

CONTROL OVERVIEW

Interaction with the water heater controller is through an UIM display called the **User Interface Module (UIM)**. This screen is also referred to as the “**desktop**” or “**desktop menu**”. Up and down buttons and three operation buttons allow navigation through the control menus and to make adjustments to the water heater. Operation of the three lower buttons is defined immediately above them on the screen.

While the water heater is operating, the user interface will display the UIM screen (if there are no active faults or warnings).

An example of this screen is shown below.

- The first temperature on this screen is the temperature of the water inside the tank.
- The second temperature on this screen is the *Operating Set Point*. The *Operating Set Point* is the temperature at which the water heater will maintain the water inside the tank.
- The third line on the screen is a text description of the Operational State of the water heater. The operational state of the water heater is also indicated graphically by status icons.

UIM (User Interface Module)

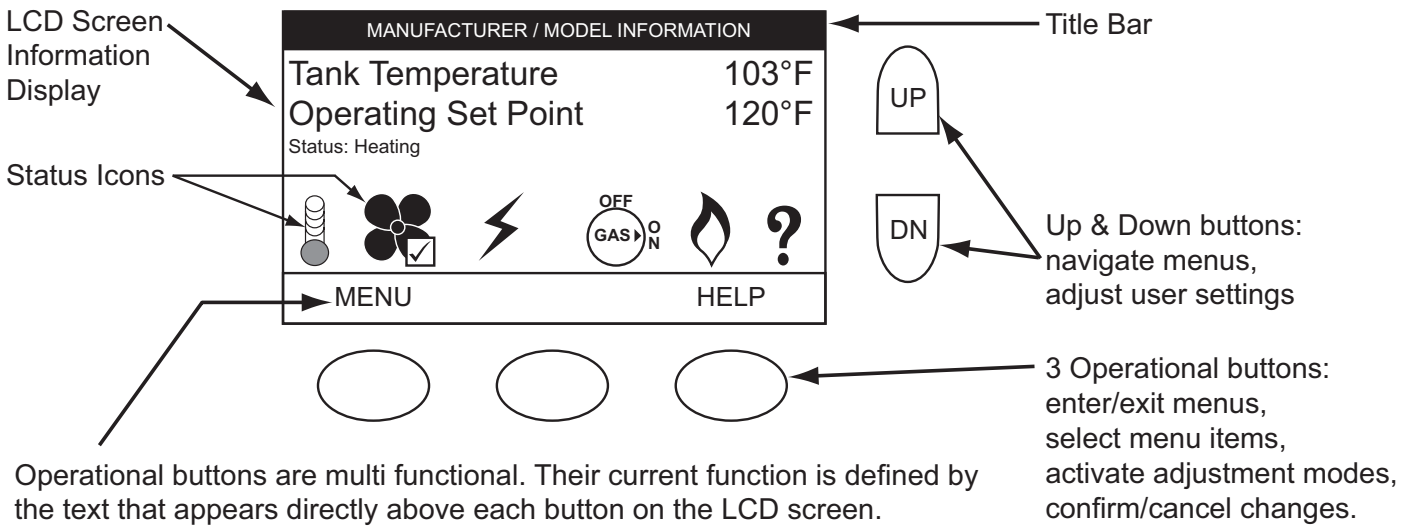

(UIM) User Interface Module Screen

COMMERCIAL GAS HIGH EFFICIENCY WATER HEATERS

Visit the "Information Central" link of www.statewaterheaters.com for a listing of available Service Handbooks.

For additional information contact:

State Water Heaters

500 Tennessee Waltz Parkway

Ashland City, TN 37015

1-800-527-1953

www.statewaterheaters.com